

Gazelle®

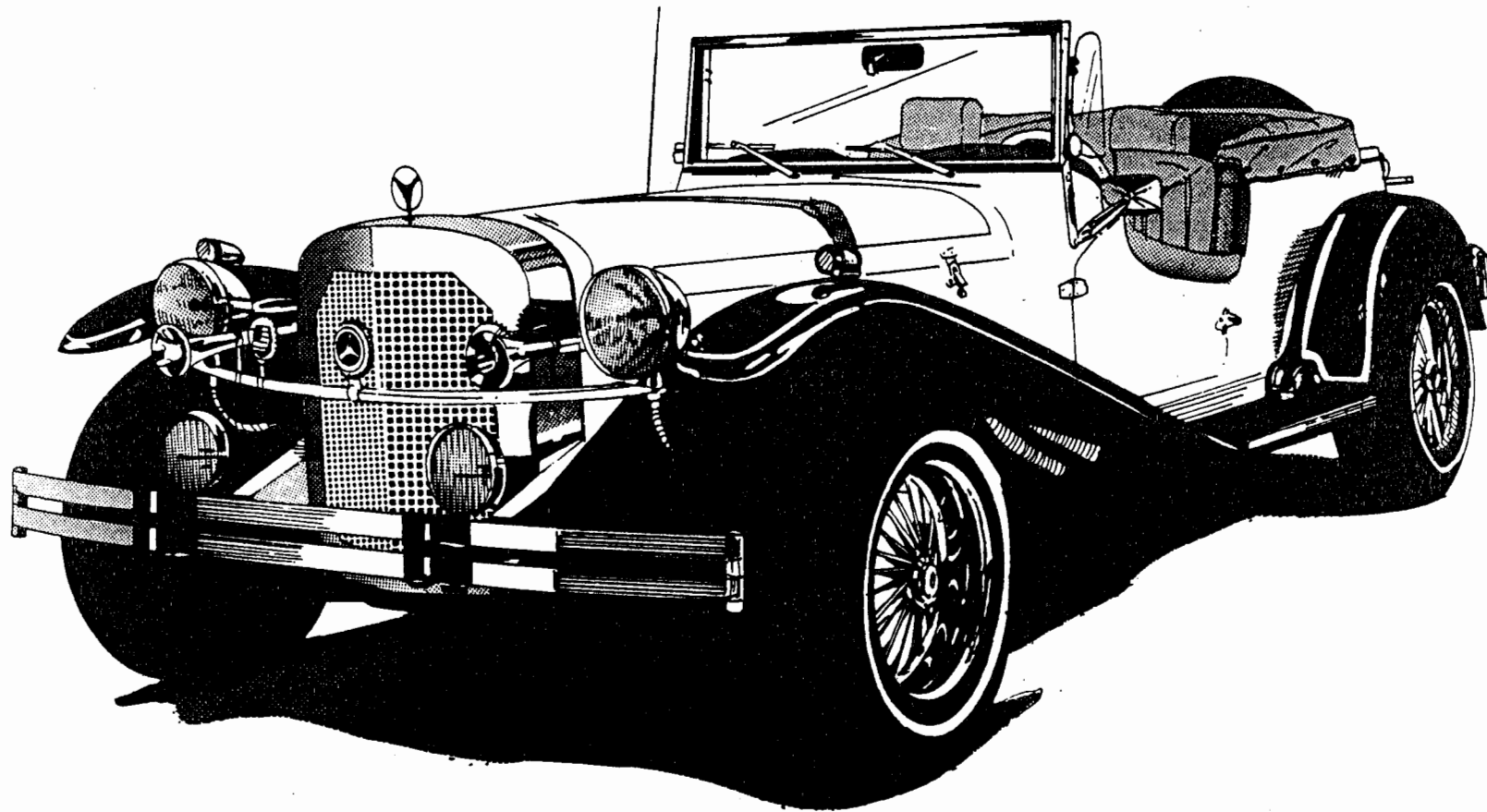

CHEVETTE ASSEMBLY MANUAL

09-0012-00

SECOND EDITION 3/85

COPYRIGHT 1984



CLASSIC MOTOR CARRIAGES
16650 N.W. 27th AVE. MIAMI, FLORIDA 33054

TABLE OF CONTENTS

SECTION I INTRODUCTION - PARTS, TOOLS AND SPECIFICATIONS

Parts To Be Purchased	1-1
Tools To Be Rented	1-1
Tools And Parts (Miscellaneous)	1-2
Considerations When Buying A Chevette	1-3
Wheels And Tires	1-4
Hardware And Fasteners	1-5

SECTION II DISASSEMBLY

Chevette Disassembly	2-1
Gas Tank	2-2
Rear End	2-2
Exhaust	2-4
Engine Compartment	2-5
Steering Column	2-7
Wiring Removal	2-9
Shifter And Emergency Brake Lever	2-10
Pedal Assembly	2-11
Front Cross Member	2-12
Checking The Components	2-12

SECTION III CHASSIS ASSEMBLY

Chassis Assembly (Rear End)	3-1
Front Suspension	3-3
Firewall	3-5
Motor Mounts	3-6
Pedal And Master Cylinder	3-6
Brake And Fuel Lines	3-8
Engine Installation	3-9
Front Springs	3-10
Front Shock Mounting	3-10
Gauge Sender Installation (If Using Optional Gauges)	3-12
Temperature Sender	3-12
Pressure Sender	3-12
Exhaust System	3-12
Steering Column	3-14
Air Conditioner (Optional)	3-16
Radiator	3-17
Drive Shaft Shortening	3-18
Fuse Block And Underdash Harness	3-19

Battery Box And Computer	3-20
Interior Liner	3-21
Emergency Brake Cables	3-23
Rear Harness Run	3-24
Shift Linkage	3-25
Heater (Optional)	3-26
Accelerator	3-27
Accelerator Cable	3-27
Other Accessories	3-27
Painting	3-27

SECTION IV BODY PREASSEMBLY

Fiberglass Preparation	4-1
Body Assembly	4-2
Front Fenders	4-2
Rear Fenders	4-3
Body Cut Outs	4-4
Exhaust Stacks (Optional)	4-4
Taillights	4-6
Parking Lights	4-7
Dashboard Assembly And Wiring	4-7
Dashboard Attachment And Slot For Steering Column	4-8
Defroster Duct Installation (Optional)	4-9
Installing Windshield Wiper Motor	4-9
Windshield Washer (Optional)	4-9
Mounting The Hood	4-10
Painting	4-10
Radiator Shell Mounting	4-11
Hood Ornament	4-11

SECTION V BODY AND CHASSIS ASSEMBLY

Mating Body To Chassis	5-1
Front Bumpers	5-2
Rear Bumper Brackets	5-3
Gas Tank	5-4
Body Attachment	5-5
Trunk Liner	5-6
Fuel Filler Neck	5-7
Door Cut-Outs	5-7
Glassing The Body	5-8
Rear Seat And Rear Deck Lid Assembly	5-10

TABLE OF CONTENTS

Door Fabrication (Optional Slam Lock)	5-11
Standard Door Locks	5-11
Door Hinges	5-11
Door Instalation	5-13
Running Board Brackets (Optional)	5-14
Running Board (Optional)	5-15
Front Bumper (Standard)	5-16
Flat Bar (Optional)	5-16
Rear Bumpers And Covers	5-17
Spare Tire Mount	5-18
Backup Lights	5-18
Chrome License Assembly	5-19
Front Fender Brackets	5-19
Badge Bar And Headlights	5-19
Trumpet Horns (Optional)	5-20
Final Alignment	5-20
Optional Badges	5-20
Fog Lights (Optional)	5-20

SECTION VI UPHOLSTERY TRIM AND TOP

Upholstery	6-1
Carpeting	6-1
Rear Seat	6-4
Rear Seat Cushion	6-6
Rear Deck Lid	6-7
Seat Track Modifications	6-8
Front Seat Fabrication	6-9
Steering Wheel (Optional)	6-12
Hornbutton Modification	6-12
Seat Belts	6-12
Seat Installation	6-13

Padded Roll	6-14
Antenna (Optional)	6-15
Windshield	6-16
Wind Wings (Optional)	6-17
Door Trim Strips	6-18
Convertible Top	6-19
Standard Top	6-19
Coupe Top	6-21
Side Curtains	6-23
Boot Cover	6-24
Leather Hood Strap	6-24
Luggage Rack (Coupe Top)	6-24
Mirrors	6-25
Radiator Ornament (Optional)	6-27
Tonneau Cover (Optional)	6-26

SECTION VII WIRING

Wiring	7-1
------------------	-----

SECTION VIII APPENDIX

Fiberglass Care And Repair	8-1
Pre-Operations Check List	8-3
Hardware	8-4
Nut and Bolt Kit	8-5

SECTION IX ADDENDUMS

Index	9-1
-----------------	-----

Refer to Section IX (Addendums) for the latest revisions.

PARTS TO BE PURCHASED

IMPORTANT: Order these items early due to possible delays with your local dealer.

*It is advisable to order a Chevette factory shop manual available through Helm, Inc., P.O. Box 07130, Detroit, MI 48207 (313) 865-5000 or a Chilton Repair & Tune Up Guide from your local auto supply store.

Muffler - Quick-Trip Turbo Muffler 65-1814 or equivalent (3 1/4" x 6" x 18" oval) with offset inlet and outlet.

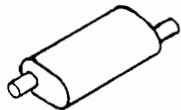

Brake Lines 3/16" x 15' steel - available in 12", 20", 40", or 60" lengths.

Gas feed lines 5/16" x 10' steel - available in 12", 20", 40" or 60" lengths.

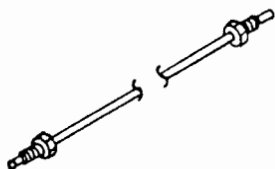

Gas vaporline 1/4" x 10' steel - available in 12", 20", 40", or 60" lengths.

Double flare female couplings for above lines (as required).



Shocks - front NAPA 2067, or optional shock or equivalent. Trim bushing to fit.

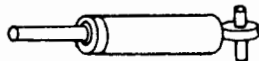

Shocks - rear NAPA 2132N, or optional shock or equivalent.

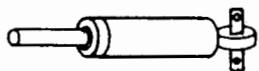

NOTE: We have found that the stock Chevette rear springs may not be stiff enough for the Replica assembly. We recommend that you use heavier springs (NAPA 277-5095) or their equivalent. Use of these will improve the over-all ride and handling of the vehicle.



Strap-type tail pipe hanger for 1 3/4" O.D. pipe.



1 1/2" length of heavy steel tube, 1/4" N.P.T. threading each end and a 1/4" N.P.T. "tee" fitting (for pressure sender extension). **NOTE:** Supplied with custom gauges.



20" of 8 x 1.25mm rod for shift extension.

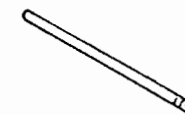

Volkswagon windshield wiper motor (15 3/4" or 16" between spindles)

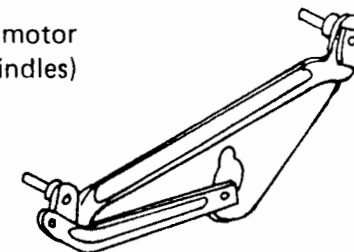

TOOLS TO BE RENTED

Hydraulic Engine Hoist

Floor Jack

Neoprene gas filter pipe 1 1/4 x 18"

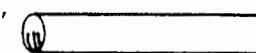

TOOLS AND PARTS

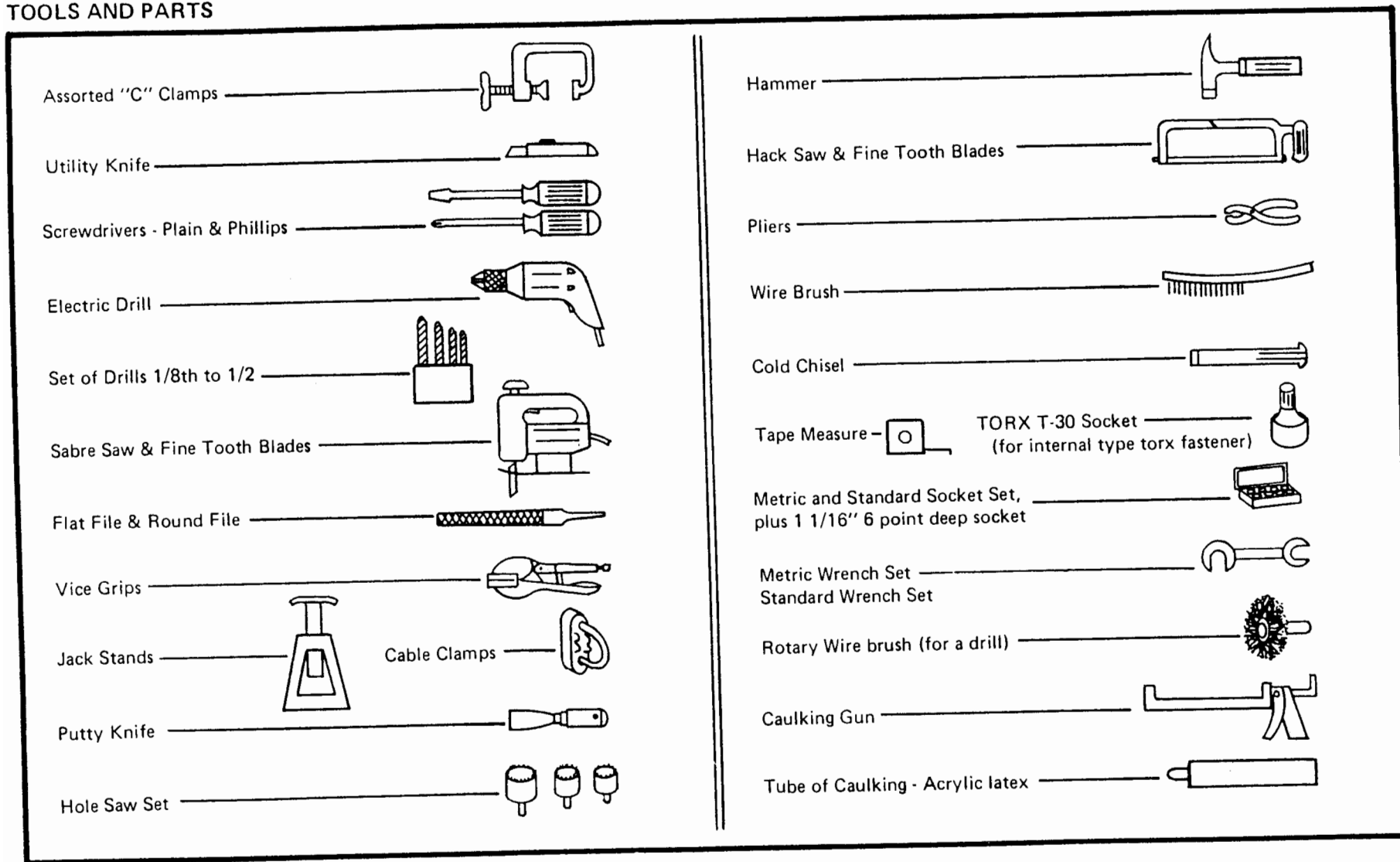

MISCELLANEOUS ITEMS

Spray cans of black paint
 Sandpaper - 60, 80, 220, 400, 600 grit
 Pop rivet gun
 Large tube of contact cement
 Staple Gun

1 qt. of Rust Retardant Paint
 4 sq. yards of 1½ oz. fiberglass mat
 or 30 ft. of 6" wide fiberglass tape
 Two 2" brushes (throw away bristle
 type)
 China Marker (Grease Pencil)

Can of Penetrating Oil
 Mineral Spirits
 6 sq. ft. of rubber matting
 20 ft. of 1/4 x 3/4" foam
 weather stripping
 2 cans 3M "90" spray adhesive

1 can 3M "77" spray adhesive
 Gallon of Polyester fiberglass resin and
 hardener (Methyl Ethyl Ketone)
 1 quart of Acetone or any safe resin
 solvent for brush cleaning
 2 ft. of 1/4" inside dia. neoprene gas line
 2 ft. of 5/16" inside dia. neoprene gas line
 2 Saw Horses 50" wide, 30" high

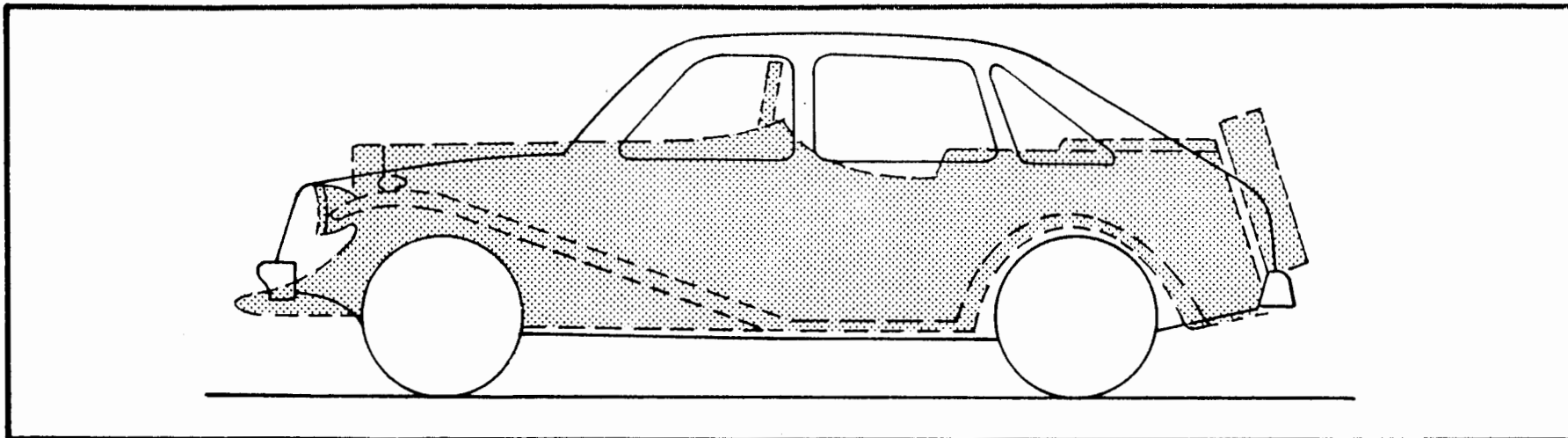

REPLICA BODY SUPERIMPOSED OVER CHEVETTE

CONSIDERATIONS WHEN BUYING A CHEVETTE

TYPES

The assembly can be built using any year Chevrolet Chevette. However, it is advisable to build the car on as late a model as possible.

The kit was designed to use a Chevette with automatic transmission. A standard transmission can be installed but will require minor modifications.

We recommend that you purchase a Chevette without air conditioning and install an add-on unit such as the one available from our factory. The radiator, condenser, and evaporator from an air conditioned car will all have to be replaced.

Due to the space limitations in the kit, power brake and steering should not be used; nor are they needed with the decreased weight of the Replica assembly.

WHERE TO FIND A CHEVETTE

Local Newspaper Classified Advertisements
 Automobile Salvage yards - Dealerships
 Neighborhood Flyers/Newspapers
 Used Car Dealerships - Repair garages
 Bulletin Boards in Gas Stations, Supermarkets, Apartment complexes, Schools, Colleges and Places of Work

Tell your friends and fellow workers about your project - they may help.

BUY A COMPLETE CHASSIS

We strongly recommend that you buy a complete Chevette and strip it yourself rather than try to buy the parts separately. While your initial outlay may be more, your overall cost will be lower and you will have the convenience of having all the parts you need readily available.

BEFORE BUYING A CHEVETTE

Before you begin, purchase a Chevette repair manual. This will help you identify the parts which you will want to check. Remember that cars with damaged bodies and interiors can be used to assemble your Replica. As a matter of fact, a damaged car is ideal if the main components are not damaged.

- Inspect the front end for damage. There should be no bent or kinked parts. Damaged shocks are no concern as they will be replaced.
- Check steering and brakes. Look for excessive play in the steering. Check for leaky wheel cylinders or master cylinder. These are easily replaced after removal from the body.
- Check the transmission. It should shift smoothly and quietly .

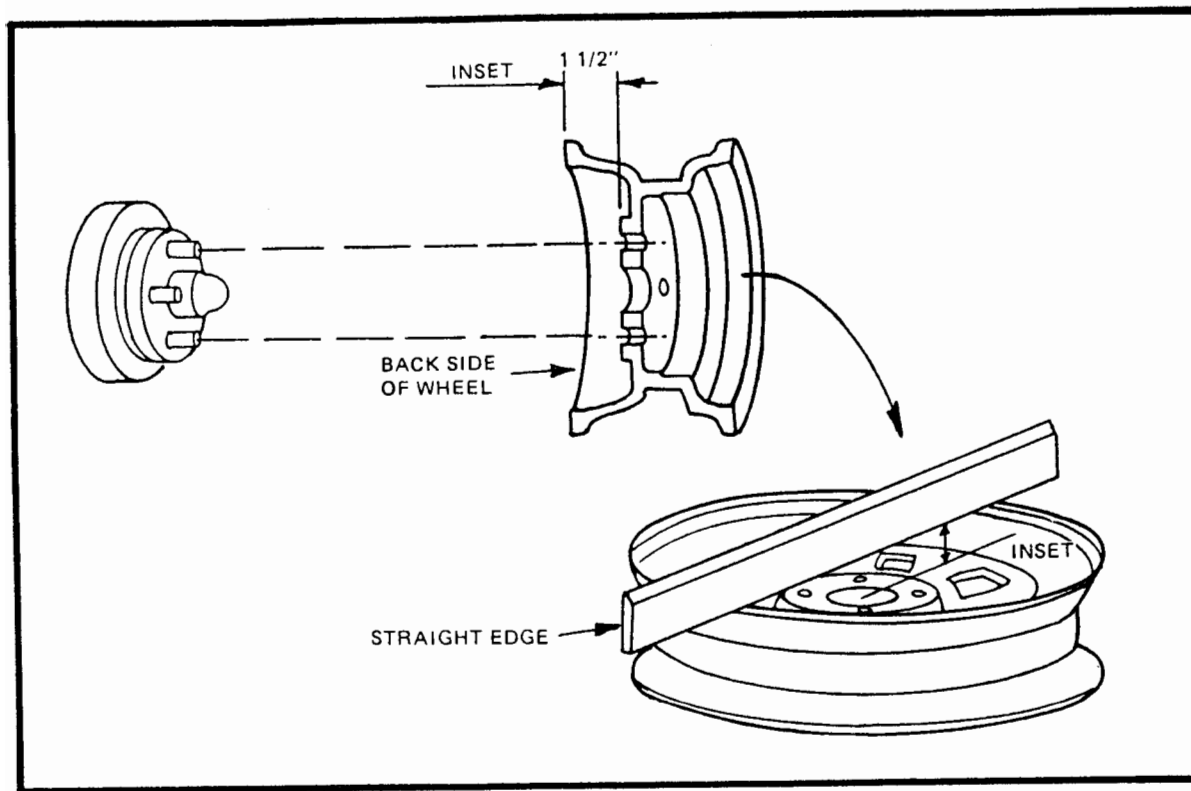

Figure 1

Before you begin, we suggest that you read the manual carefully to get an overall picture of the construction steps. You will have to organize your parts, tools, assembly materials, and work space for the task. This manual gives a step-by-step procedure similar to that used to assemble new cars at our factory.

WORKING SPACE

You need a working space approximately the size of a two-car garage. The assembled chassis measures 156 inches by 68 inches wide. The fiberglass body occupies approximately the same space. During initial construction you will need room for both the chassis and the body until both are finished. Once the fiberglass body is mated to the chassis, only half the original space is required.

Be sure to allow sufficient space for walking, storage of parts, and access to the car.

- Check the engine. High mileage cars should not be disregarded as the Chevette engine has proven itself as a workhorse capable of years of reliable service. Use your Chevette manual to check the engine for possible trouble spots. (Check oil pressure, compression, etc.)

A Chevette that has been rolled over would be ideal as long as no engine or drive train components have been damaged.

WHEELS AND TIRES

Due to the configuration of the body and frame, the stock 13" wheels and tires from

the Chevette do not give adequate road clearance and give the car a disproportionate look.

The car was designed to operate with 14" wheels and radial 195R-14.

Because of the fit of the fenders and body, 14" wheels with a 1 1/2" inset are required. Inset is measured as per diagram.

These wheels are available from our factory as an option should you have difficulty finding them locally.

UNPACKING

Your Replicar assembly is shipped in one or more crates and number of cardboard cartons. The total number of items in the shipment is indicated on the shipping documents. Since you may have ordered options, the number of items in your shipment may differ from other customers. Be sure to sign the bill of lading noting any observable damage.

Carefully check each container for evidence of damage to container or contents. If you find damage, immediately call the shipper's local office and follow shipper's instructions for submitting a claim.

HARDWARE AND FASTENERS

When disassembling your Chevette be sure to save all hardware. Most of this hardware will be reused when assembling the kit. Take special care to keep nuts, bolts, and washers in the proper order.

WARNING

NOTE: Check factory service manual for torque specifications when reassembling removed hardware. There are some bolts that the manufacturer suggests should not be used after removal.

Structural bolts and nuts should only be replaced with equivalent parts. Replacement parts must be of equal or better strength as indicated by standard bolt and nut markings (radial lines on bolt head, raised dots on nuts).

Special chrome hardware is supplied with the deluxe kit. However, ordinary fasteners are not supplied since they can be obtained from hardware or automotive supply houses. For your convenience an optional nut and bolt package is available.

WIRING

This assembly uses most of the wiring found on your Chevette. The only additional wiring consists of an instrument harness.

Several choices are available. First, you can purchase our optional wiring harness. This method is a real timesaver, especially if you buy our optional gauges.

Another method is to fabricate your own dash harness, based upon wiring diagrams available from G.M.

WELDING

All structural parts can be bolted in place. However, a minimal amount of welding is recommended. The parts you choose to weld are dependent only on your preferences. Welding usually gives greater strength and it prevents the possibility of bolts working loose.

Parts that may be welded include the rear bumper brackets, drive shaft, steering shaft, running boards, and exhaust.

These parts can be welded with a small arc welder or taken to machine shop for welding. The work can usually be done in less than an hour. Most cities have mobile welders who will come to your garage or shop and do the welding. Unless you are an experienced welder, we recommend that you contract out these items.

For convenience, you can bolt the parts in place initially, then later weld them permanently all at the same time.

BEFORE STARTING

Be sure to read this manual all the way through before starting work.

- Have all the tools you need before you start.
- Be sure your work space is large enough.
- Save all parts and hardware that you remove. If you try to buy all the pieces separately they will cost a lot more.
- Have masking tape ready to label parts, attaching hardware, wires, fuel lines, clips, etc. It would also be a good idea to have a variety of small containers to hold small loose items such as nuts, bolts, and washers.
- Make sketches or take Polaroid photos of any assemblies that seem complicated. This can help you later when you are assembling the kit.
- Be aware of safety, particularly when jacking and hoisting. Never get under car unless firmly supported on jack stands.

USE COMMON SENSE

Develop safe work habits. Take every possible precaution. Follow these basic Do's and Don'ts.

DO

- Do use safety stands to support vehicles. Jacks are for lifting only.
 - Do pay attention to warning labels.
 - Do use adequate ventilation when using chemicals, spraying paint, fibreglassing. Wear a mask over mouth and nose when necessary.
 - Do use electrical extension cords of the proper gauge and with proper plugs in good condition.
 - Do read all instructions.
 - Do wear proper clothing and shoes remove ties, jewelry, and other items that can get caught in moving components.
- Do keep a fire extinguisher in your work area.
 - Do keep a first aid kit in your work area.
 - Do disconnect the battery (negative) cable whenever working on electrical system.
 - Do disconnect and remove the battery from the component car before starting disassembly.
 - Do use the proper tools.
 - Do clean and maintain your tools. Clean your work area often.
 - Do use approved containers for gasoline and flammable liquids. Put away and out of reach of children when not in use.
 - Do wear safety glasses or goggles when grinding, drilling, sanding, painting, glassing or when handling the battery.

DON'TS

- Don't smoke when working around gasoline or other flammable chemicals.
- Don't use open flame heaters around gasoline or when using flammable chemicals.
- Don't smoke when working around the battery.
- Don't run engine in a garage without proper ventilation.
- Don't attempt to service air conditioning units without proper tools or training.
- Don't use air conditioning refrigerant (R-12) in the presence of an open flame.
- Don't leave tools where someone can trip over them.

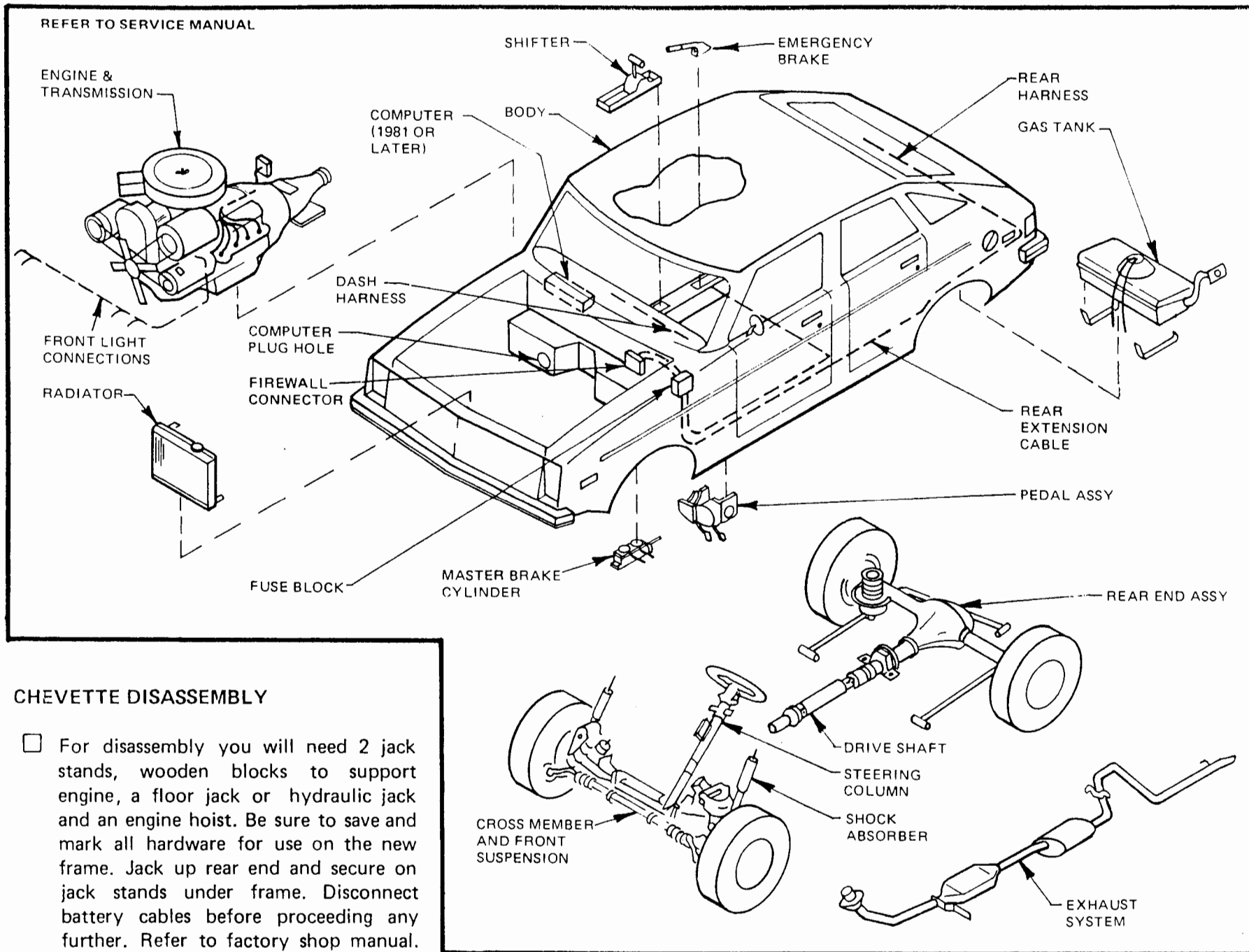
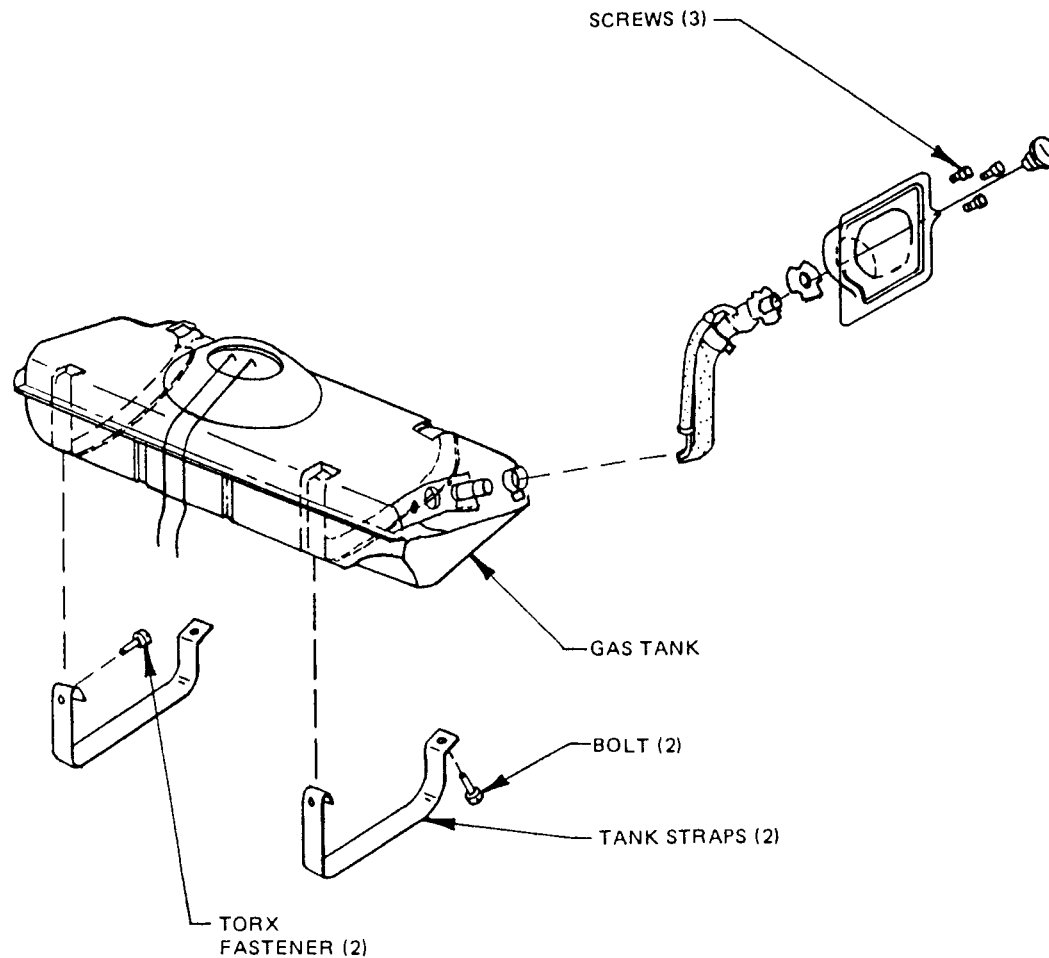

Figure 1

REFER TO FACTORY SERVICE MANUAL



WARNING

Make sure battery is disconnected and positive (plus) coil wire is disconnected. Avoid smoking in the work area. It is a good idea to have a CO₂ fire extinguisher handy. Siphon or pump fuel into an approved container.

GAS TANK

- Remove 3 screws surrounding filler cap. (Figure 2) Place floor jack under gas tank and apply upward pressure. Remove 2 rear tank strap bolts. Disconnect all lines going to tank and plug openings. Lower tank and slide rearward to remove. Using Torx T-30 socket, remove forward fasteners of straps. Save tank and straps for reuse. Make certain all gasoline is removed from tank.

REAR END

- Place floor jack under differential and apply pressure. Disconnect brake fitting where flexible hose attaches to body. Chisel off bracket for use on the new frame. Disconnect drive shaft at universal joint. (Figure 3) Remove emergency cable spring and unfasten the nut holding cable to handle.
- Drop drive shaft and pull rearward to remove. Plug end of transmission opening to prevent fluid leakage. Remove bolt holding rear tie rod to body.
- Remove bolts holding front of lower control arms to body. Remove emergency brake cable brackets. Remove 2 bolts from front support bracket at forward end of differential extension.
- Unbolt tops of shocks from trunk area of car (Figure 3) and from axle and remove. Lower differential to ground. Save all spring mounting pads.

Figure 2

REFER TO FACTORY SERVICE MANUAL

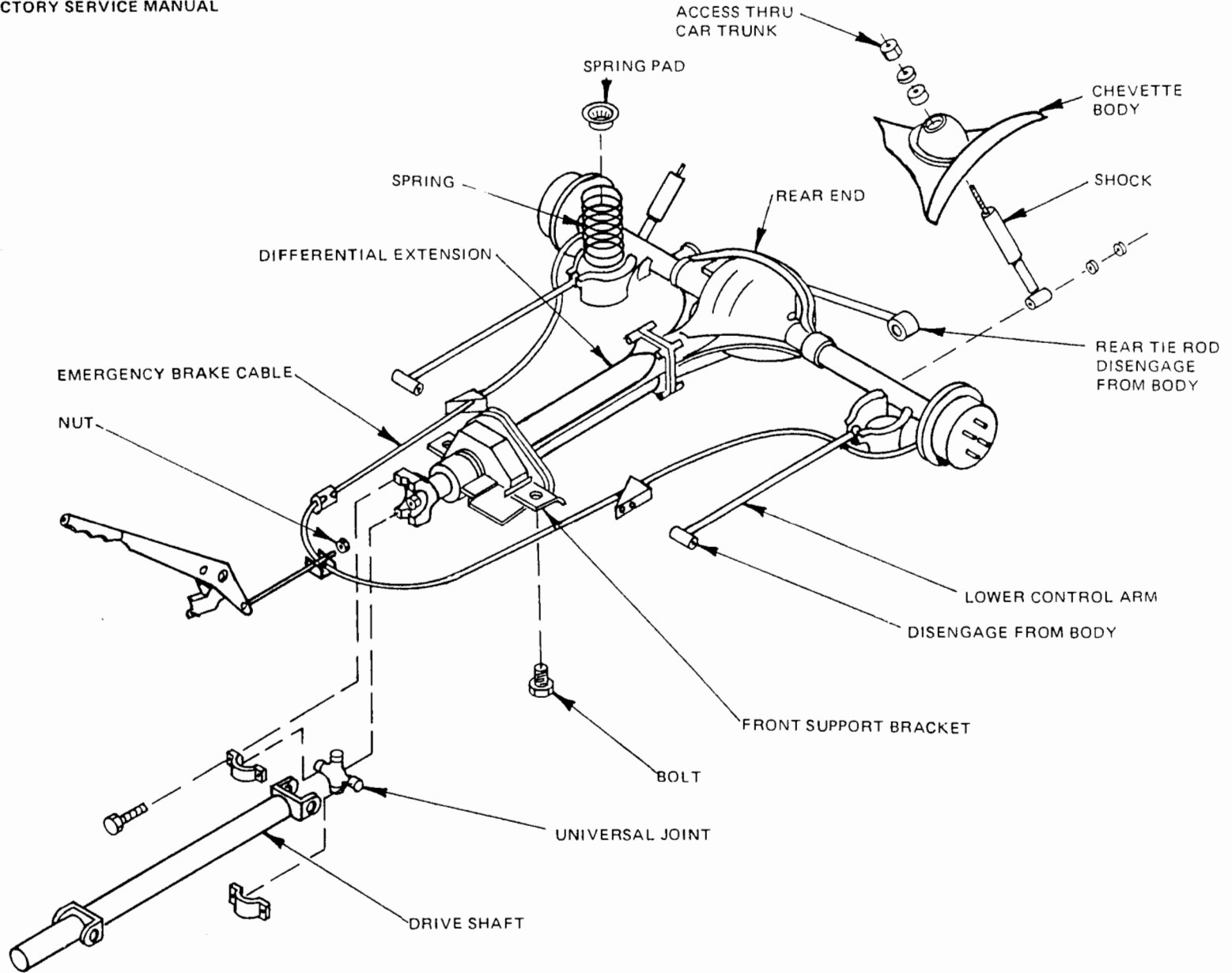
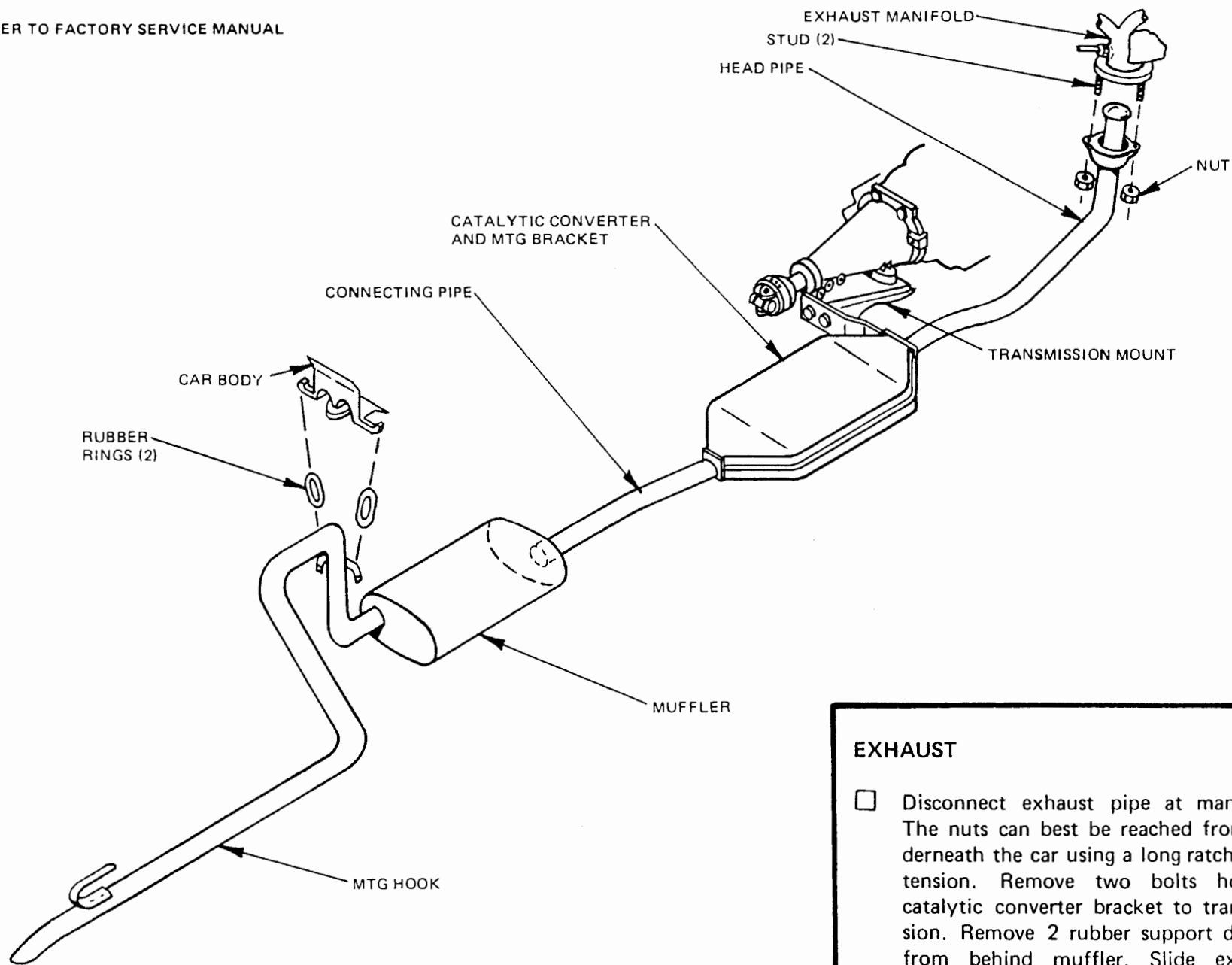

Figure 3

REFER TO FACTORY SERVICE MANUAL



EXHAUST

- Disconnect exhaust pipe at manifold. The nuts can best be reached from underneath the car using a long ratchet extension. Remove two bolts holding catalytic converter bracket to transmission. Remove 2 rubber support donuts from behind muffler. Slide exhaust system rearward to remove.

Figure 4

ENGINE COMPARTMENT

- Disconnect and remove battery. Drain radiator. Remove coolant recovery tank and disconnect radiator hoses. Mark and disconnect 2 transmission lines from radiator. Remove fan shroud, working through grille and under bumper (4 bolts). Remove upper radiator support plate (2 bolts). Lift and remove radiator. Unbolt and save 2 lower radiator supports. Save all parts for reuse.
- Remove charcoal canister. Mark all hoses for reconnection. Remove windshield washer tank from left fender well. Disconnect washer pump by left hood hinge.
- Disconnect all wires and vacuum hoses running from the engine to the body. Carefully mark all connections with masking tape to allow easy reconnection. Remove all headlight and side marker light connections. Disconnect throttle cable from accelerator pedal and pull through firewall. Remove 2 wire connectors by left hinge. (Do not cut wires.)
- Cut heater hoses where they come through firewall. Disconnect gas line at gas pump. Disconnect computer wiring plugs on passenger side (from inside car) then pull through from engine compartment. Disconnect speedometer cable at speedometer. Remove all positive battery cable hold-downs. Disconnect engine to frame grounds. Remove nuts on each side of master cylinder. From inside car, remove clip holding master cylinder pushrod to brake pedal. Disconnect brake lines at master cylinder and remove. Save spacer.

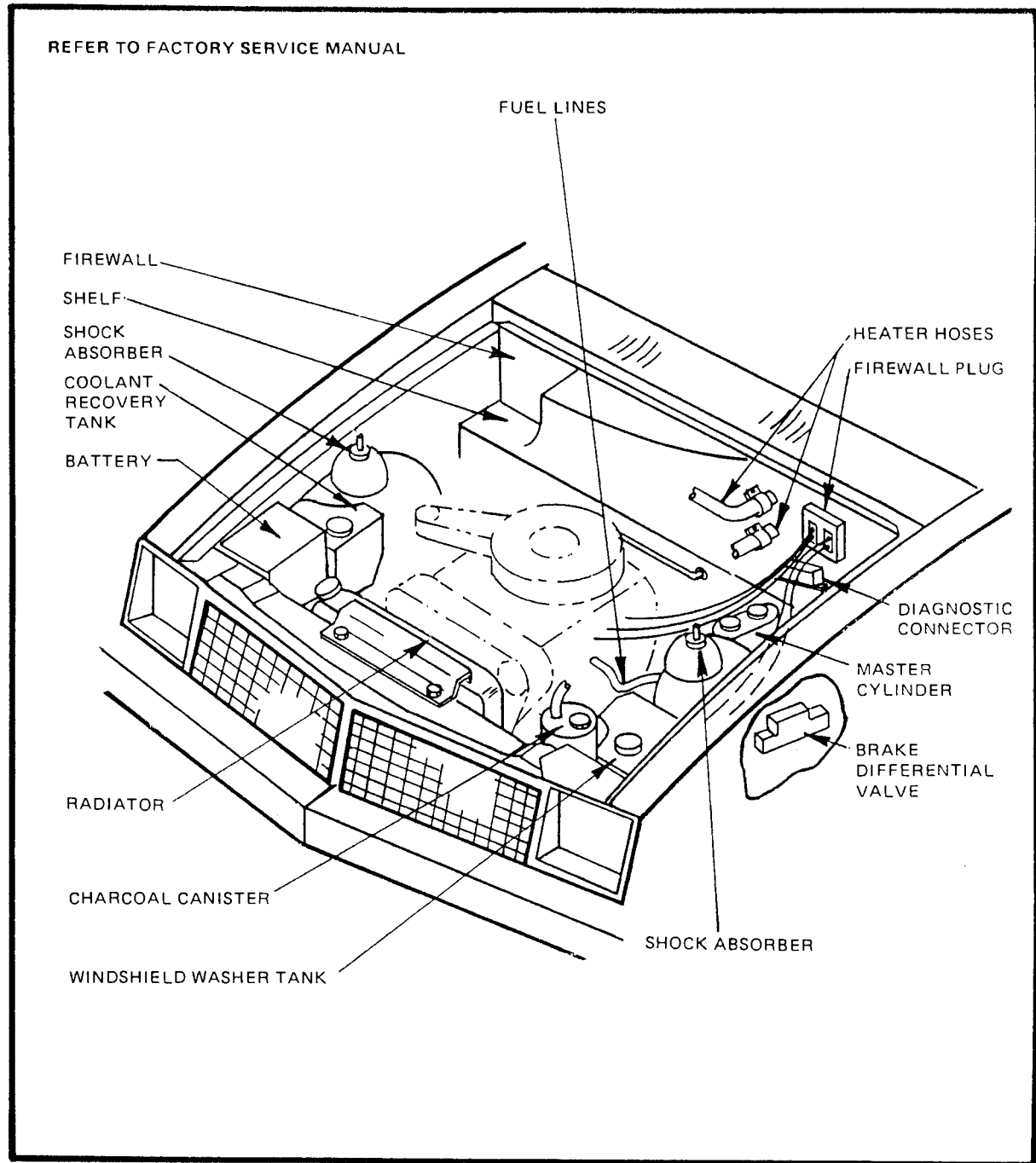

Figure 5

ENGINE COMPARTMENT (CON'T.)

- Under car, remove retainer holding shift linkage to handle. Remove nut at center of transmission mount. (Figure 6)
- Remove nuts from motor mounts. Attach hoist to eye on engine and around alternator bracket. Slowly lift engine checking for any remaining connections. Set down on wooden blocks. Remove and save transmission mount.
- Remove brake differential valve and bracket from left fender well of car.

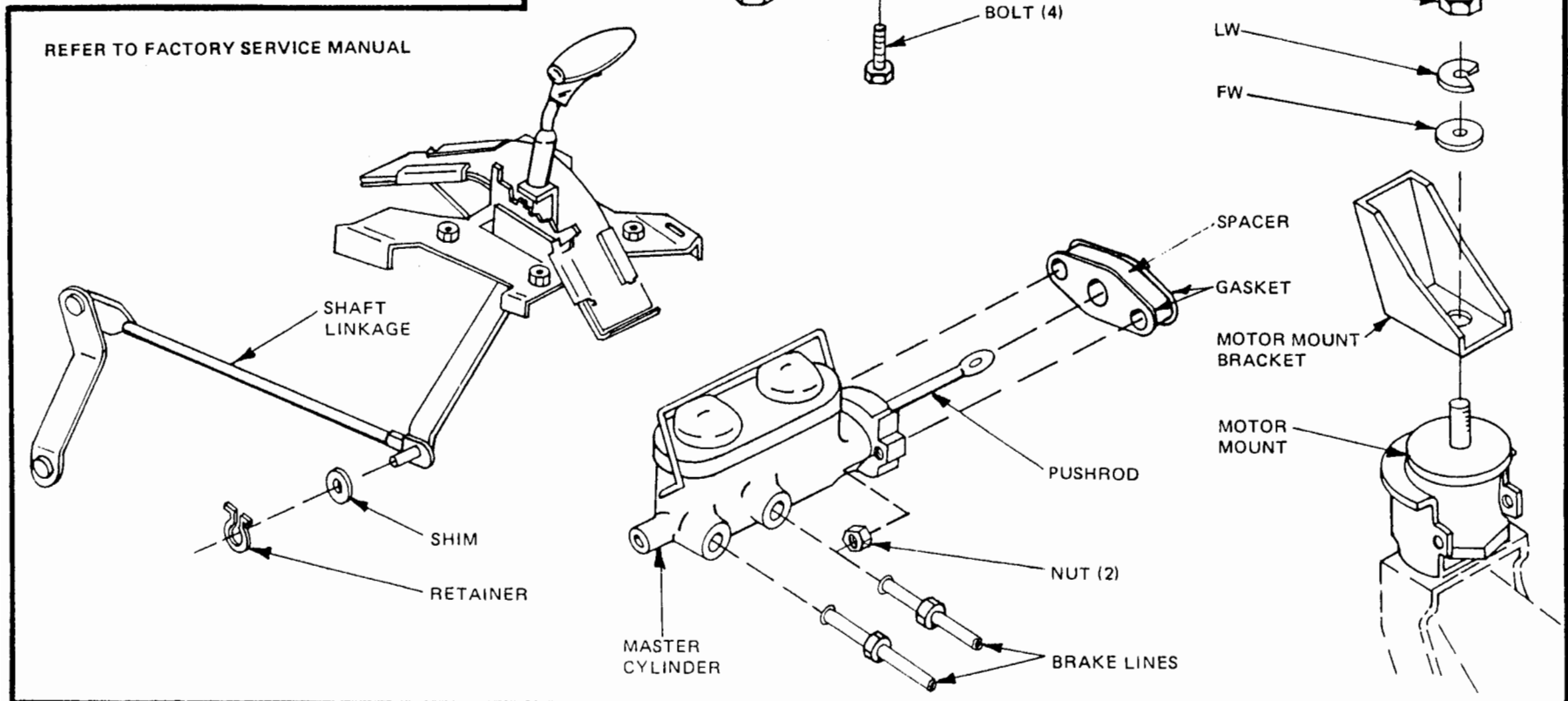

Figure 6

STEERING COLUMN

- From inside the car, remove the bolt holding the steering column tab to the firewall. Remove the 2 nuts on the underside of the column.
- Disconnect all steering column wiring plugs. Remove the 2 nuts and bolts holding the steering column to the flexible coupling disc by the rack and pinion. Pull column from car. (Figure 7)

REFER TO FACTORY SERVICE MANUAL

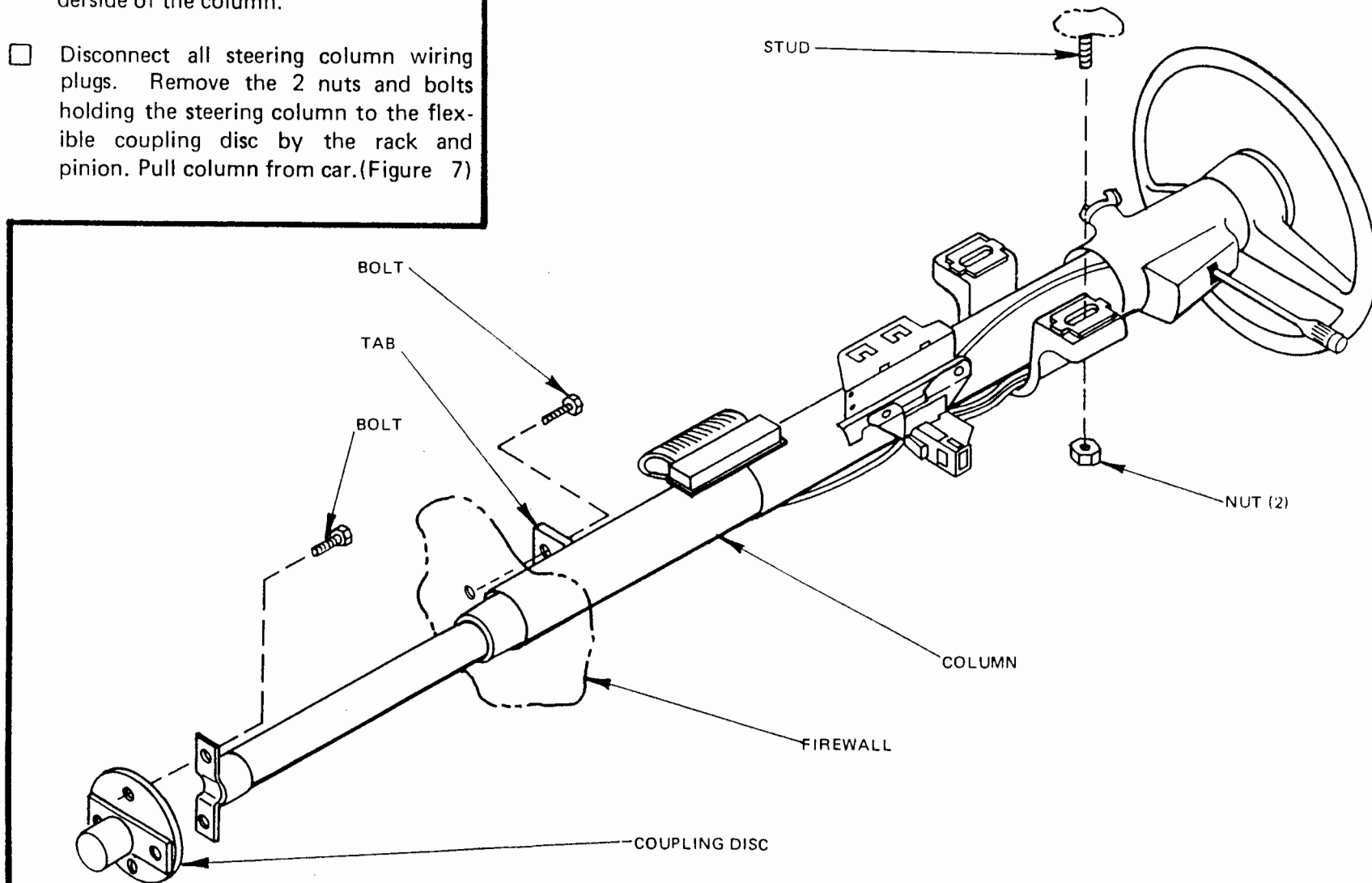

Figure 7

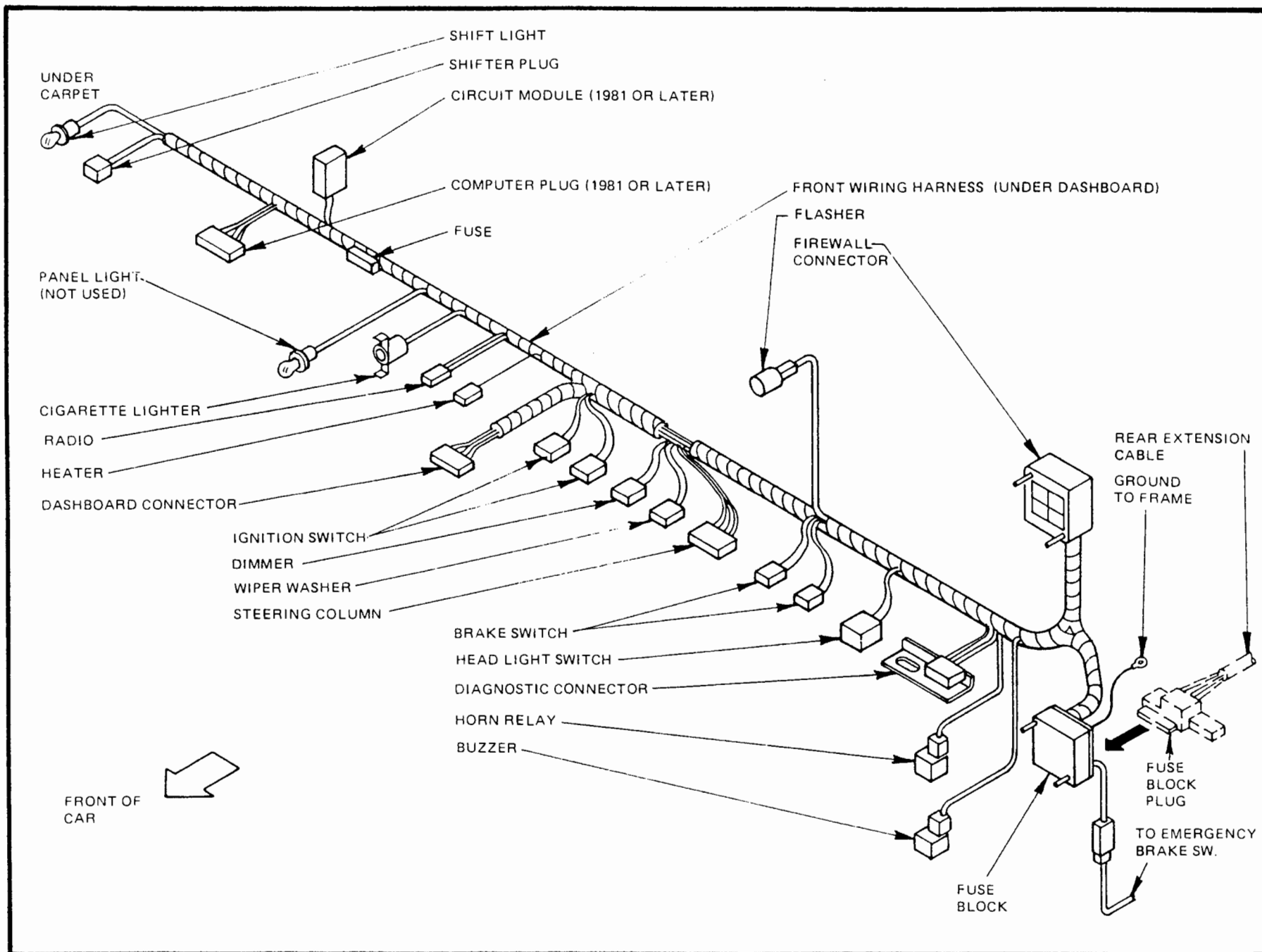

Figure 8

WIRING REMOVAL

- Disconnect all plug connections under the dash. Mark all connections with masking tape to aid reconnection. Due to variations from year to year, there may be minor differences in the wiring harness of your particular Chevette. (More or fewer connections, different locations on harness, etc.) Marking with masking tape will insure correct reconnection. Remove the fuse block and the large rubber firewall plug from the body. Remove intact. Do not cut any wires. Remove the screw holding the heavy black ground wire to the frame (near the fuse block). (Fig. 8)
- Pull up the carpet and disconnect the wires attached to the emergency brake and the shift handle.
- Unplug the connector attached to front of the fuse block that runs to the rear of the car. Detach harness from body and remove from car. On passenger side, remove computer for use on the Replica assembly, if fitted to your Chevette. Pull up carpeting on driver's side and remove wire running from fuse block to rear of car. Unplug connector located under spare tire cover. Disconnect all rear light connectors and fuel tank wires. Remove from car. (Fig. 9)
- You should now have all front light and engine connections, (removed with the engine) all under dash wiring and all rear function wiring. If custom gauges are used a harness will have to be constructed.

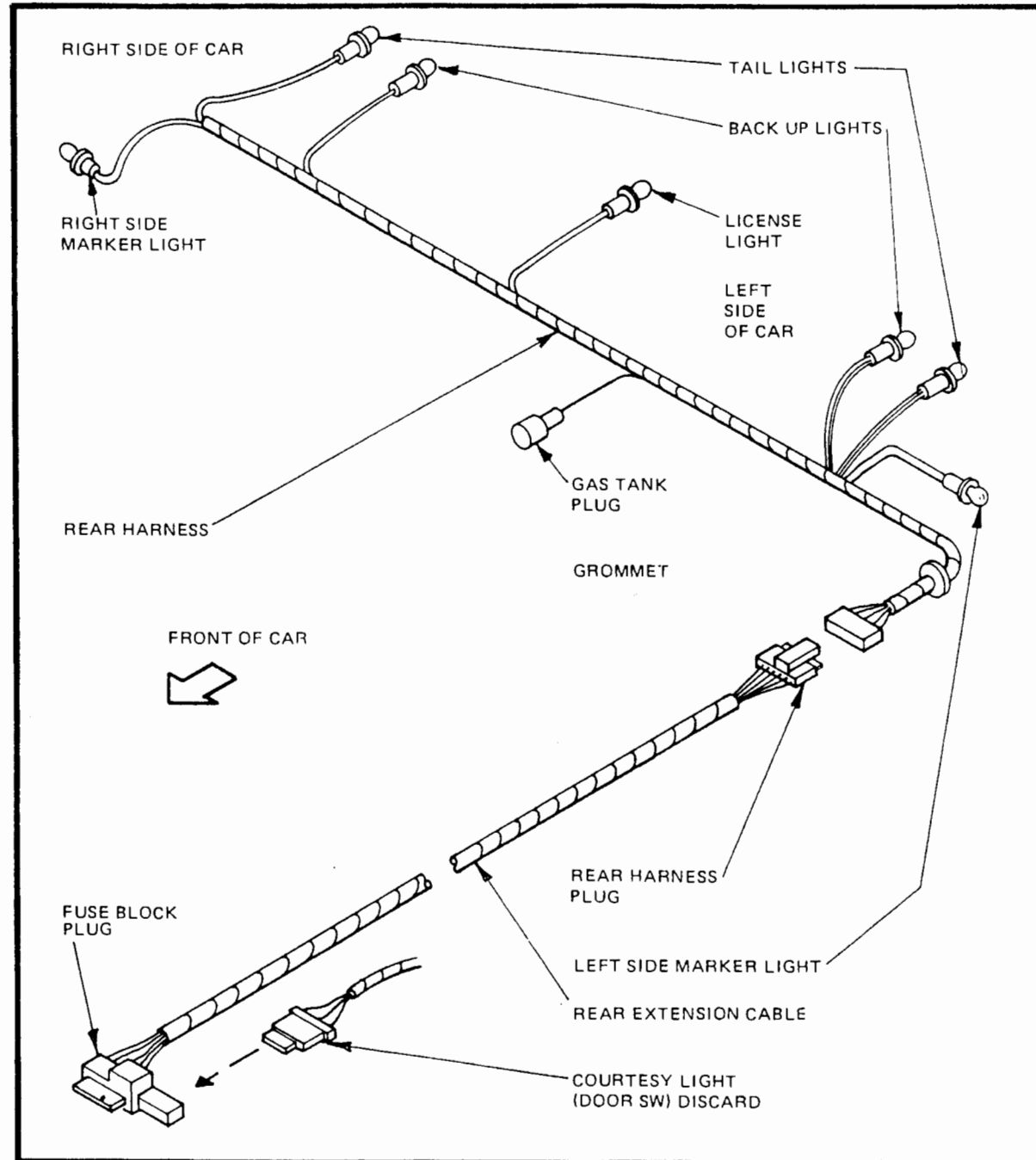
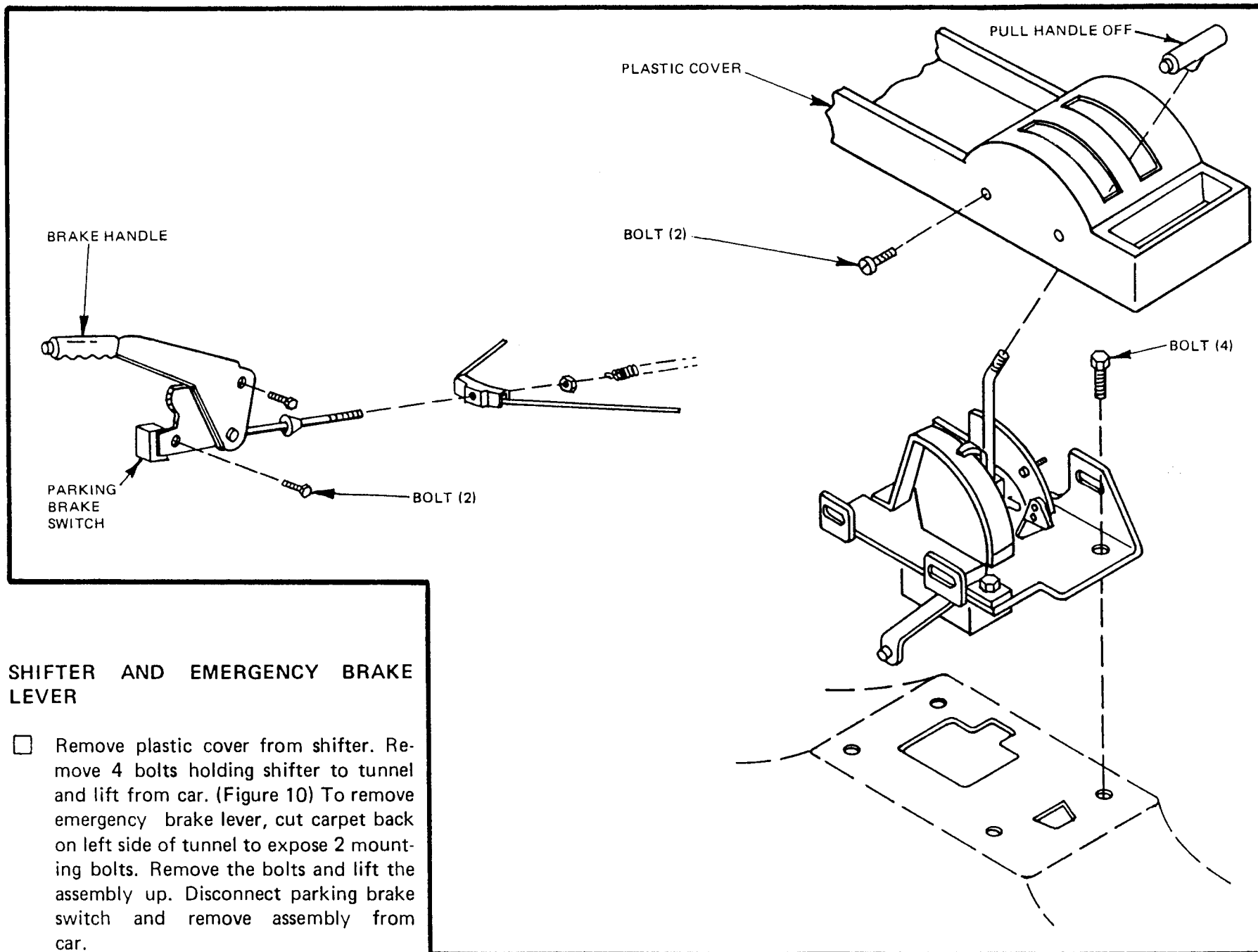

Figure 9



SHIFTER AND EMERGENCY BRAKE LEVER

- Remove plastic cover from shifter. Remove 4 bolts holding shifter to tunnel and lift from car. (Figure 10) To remove emergency brake lever, cut carpet back on left side of tunnel to expose 2 mounting bolts. Remove the bolts and lift the assembly up. Disconnect parking brake switch and remove assembly from car.

Figure 10

PEDAL ASSEMBLY

- Remove the two bolts on the horizontal surface by the left hood hinge. Remove self-tapping screw by accelerator pedal and remove assembly from car. Save all bolts. (Figure 11)

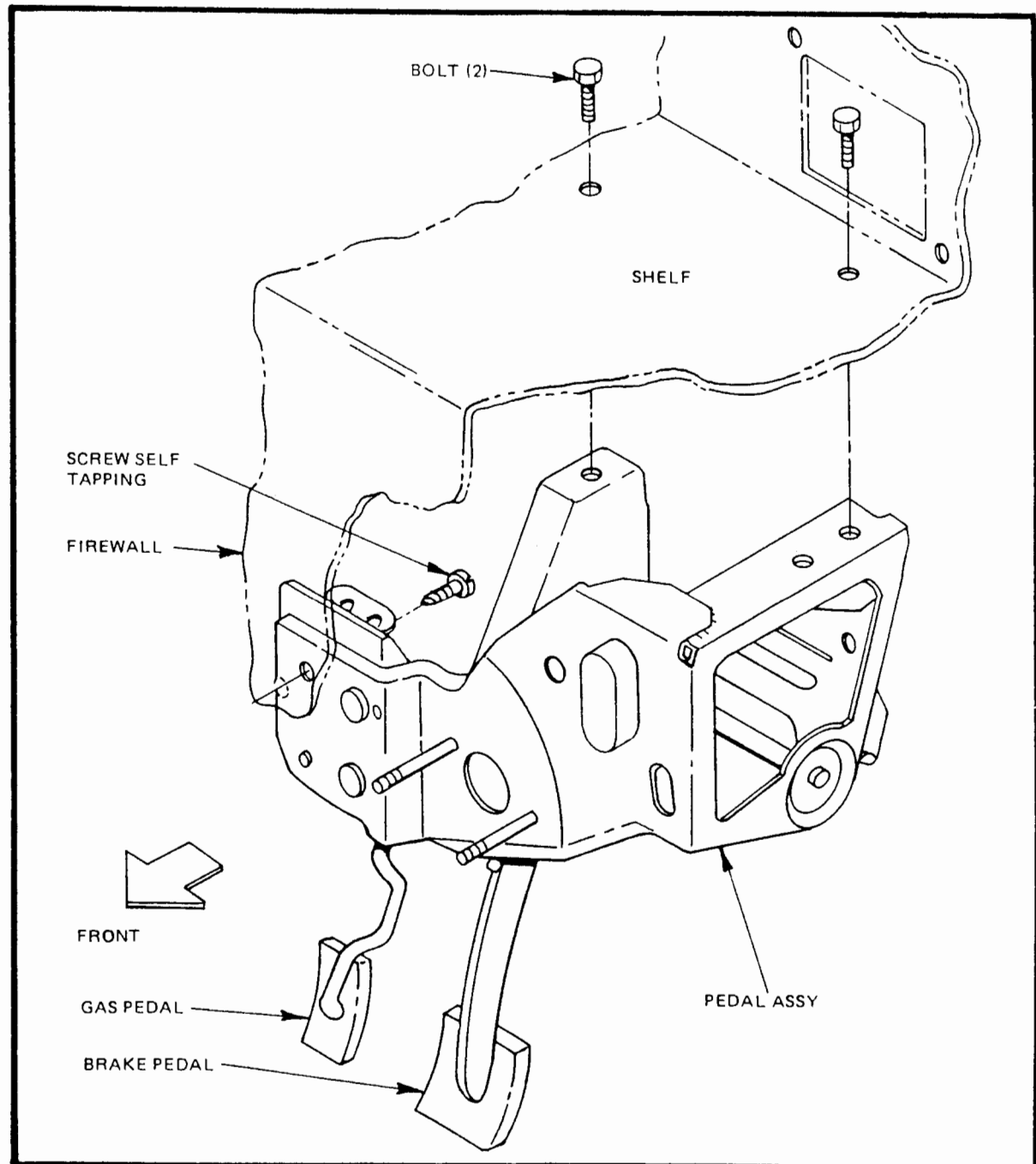

Figure 11

FRONT CROSS MEMBER

- Jack up front of car and secure on jack stands under frame. Remove wheels. Remove shock absorbers. (Figure 12) Disconnect brake lines under wheel wells and remove bolt holding bracket to car. Leave bracket attached to rubber hose. Remove stabilizer bar from lower "A" frame. Remove bolt from rear of lower "A" frame where it attaches to body. Place floor jack under cross member and jack up slightly. Remove two bolts located just below under side of upper "A" frames. Remove bolts holding cross member to frame. Lower jack and remove cross member.

- Remove all gas and brake line retaining clips for use on the Replica assembly. We recommend that all new brake and gas lines be used. You can remove all of the old lines and reuse them if they are in good condition.

CHECKING THE COMPONENTS

- Now is the time to check all components you have removed for wear. Parts that are worn or damaged should be replaced with equivalent parts from your auto supply dealer or Chevette dealer.

In addition, you may want to clean and paint some of the parts that need corrosion protection.

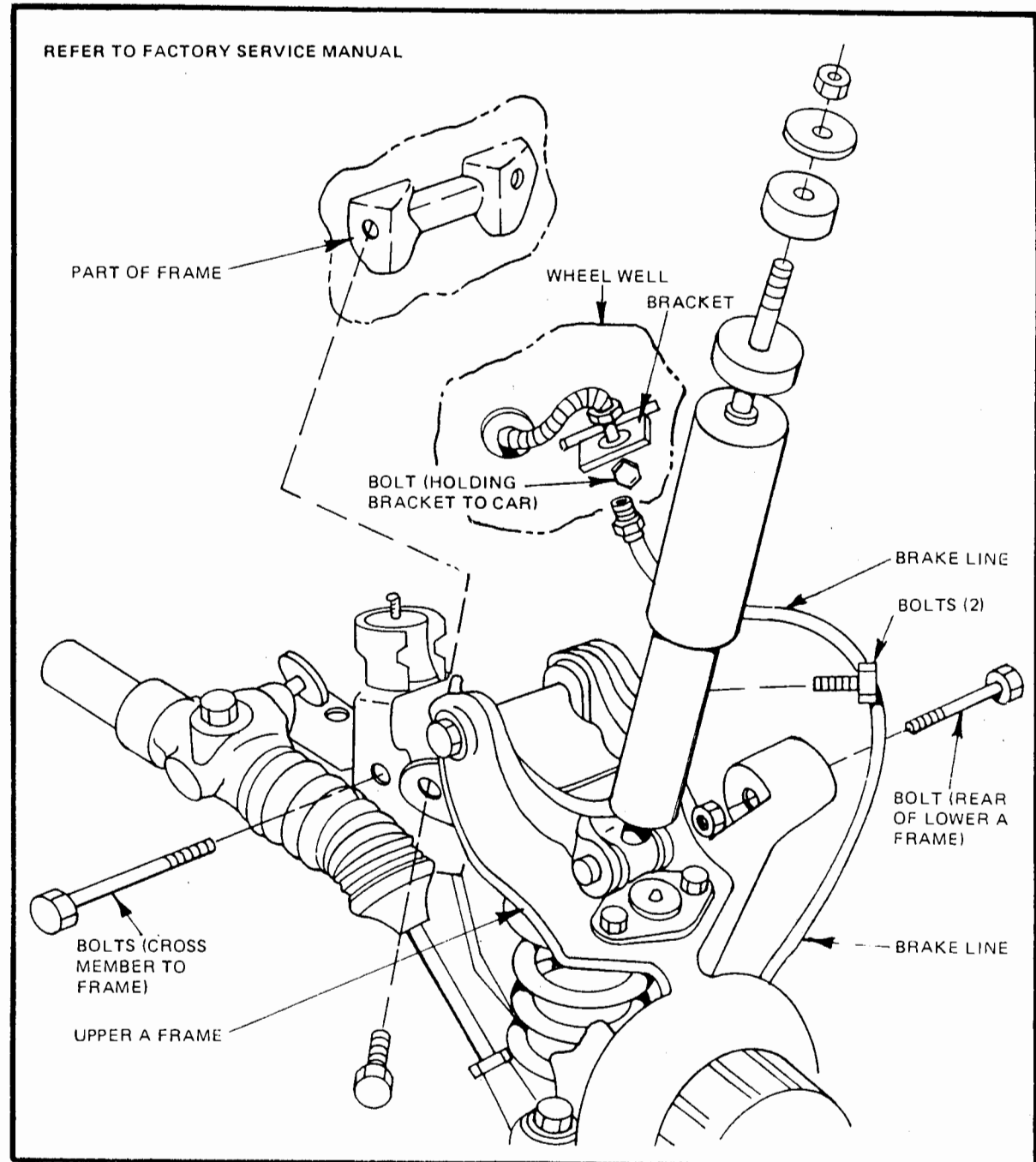

Figure 12

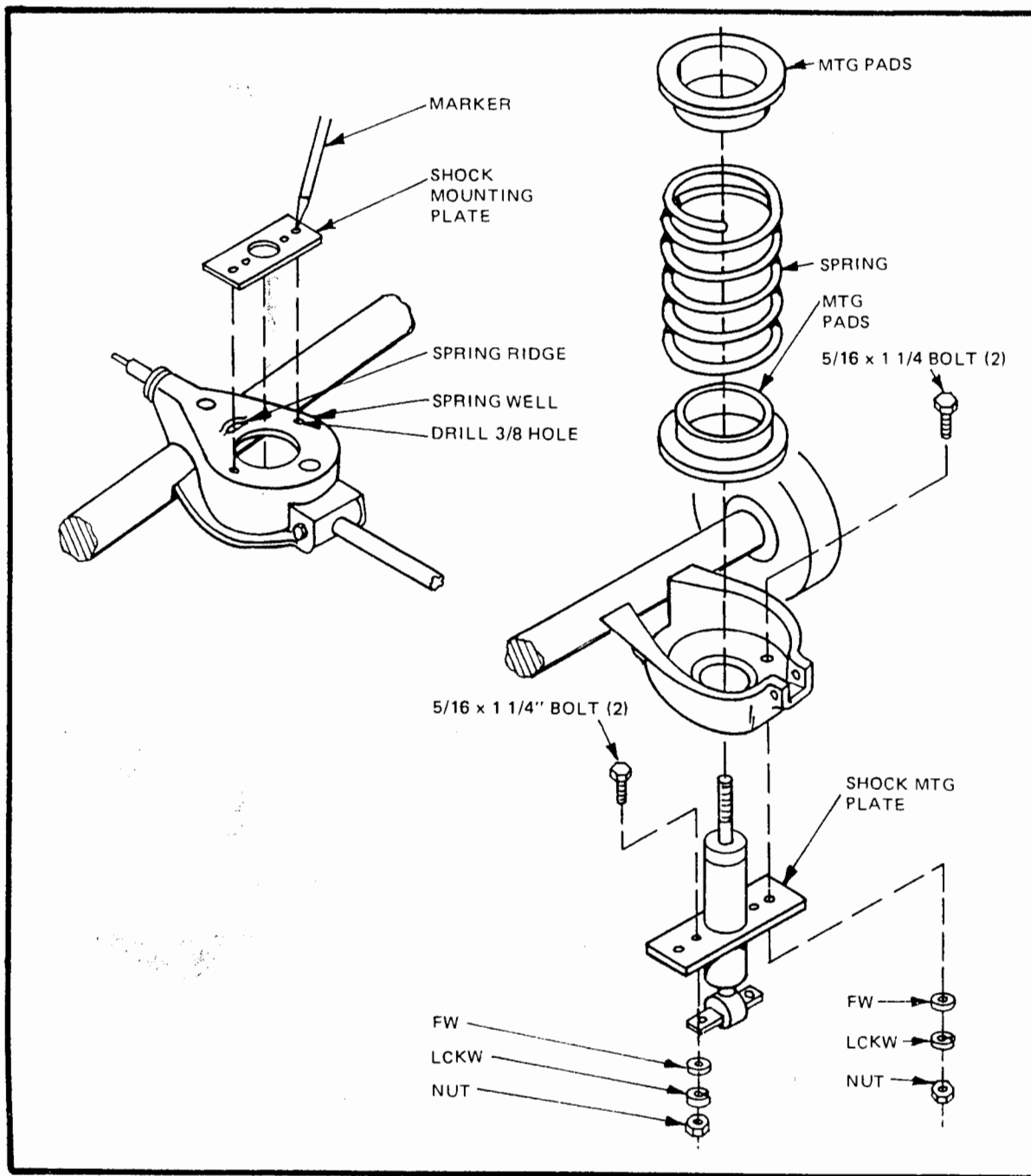

Figure 1

CHASSIS ASSEMBLY

REAR END

Because of the configuration of the Replica assembly, the original shocks cannot be used. They must be changed. An acceptable replacement is NAPA 2132 or a commercial equivalent. We use a custom shock designed specifically for the weight and handling characteristics of the Chevette Replica, and it is available as an option (see "Front Shock Mounting"). To adapt rear end, modify as follows:

Remove springs and mounting pads from their wells in the axle.

- Turn the entire assembly over, so the bottom of the spring wells are up. Using the shock mounting plates supplied as a template, lay it over the spring well, pushing it against the spring ridge as shown, and mark the hole locations. They should be evenly spaced on either side of the central hole. Drill 3/8" holes at marked locations. (Figure 1)
- Attach shocks to plate using 5/16 x 1 1/4" bolts with flat washer, lock washer and nut. Insert shock through central hole and bolt to spring well using 5/16 x 1 1/4" bolts, flat washers and nuts.
- Invert assembly and insert mounting pads and springs back into position.

REAR END (CONT.)

- Roll assembly under chassis and bolt front of differential extension onto chassis (Figure 2) using 3/8 x 1 1/4" bolts with flat washers, lock washers and nut. Hand tighten. Place a floor jack under the differential and lift so that tops of shocks can be secured. Use hardware supplied with the shocks.
- Bolt front of stabilizer bars to chassis using original bolts and nuts. Bolt tie rod to chassis using original bolt and nut. Tighten front bolts on differential extension. Release floor jack.

REFER TO FACTORY SERVICE MANUAL FOR TORQUE AND HARDWARE SPECIFICATIONS

NOTE: We have found that the stock Chevette rear springs may not be stiff enough for the Replica assembly. We recommend that you use heavier springs (NAPA 277-3095) or their equivalent. Use of these will improve the over-all ride and handling of the vehicle.

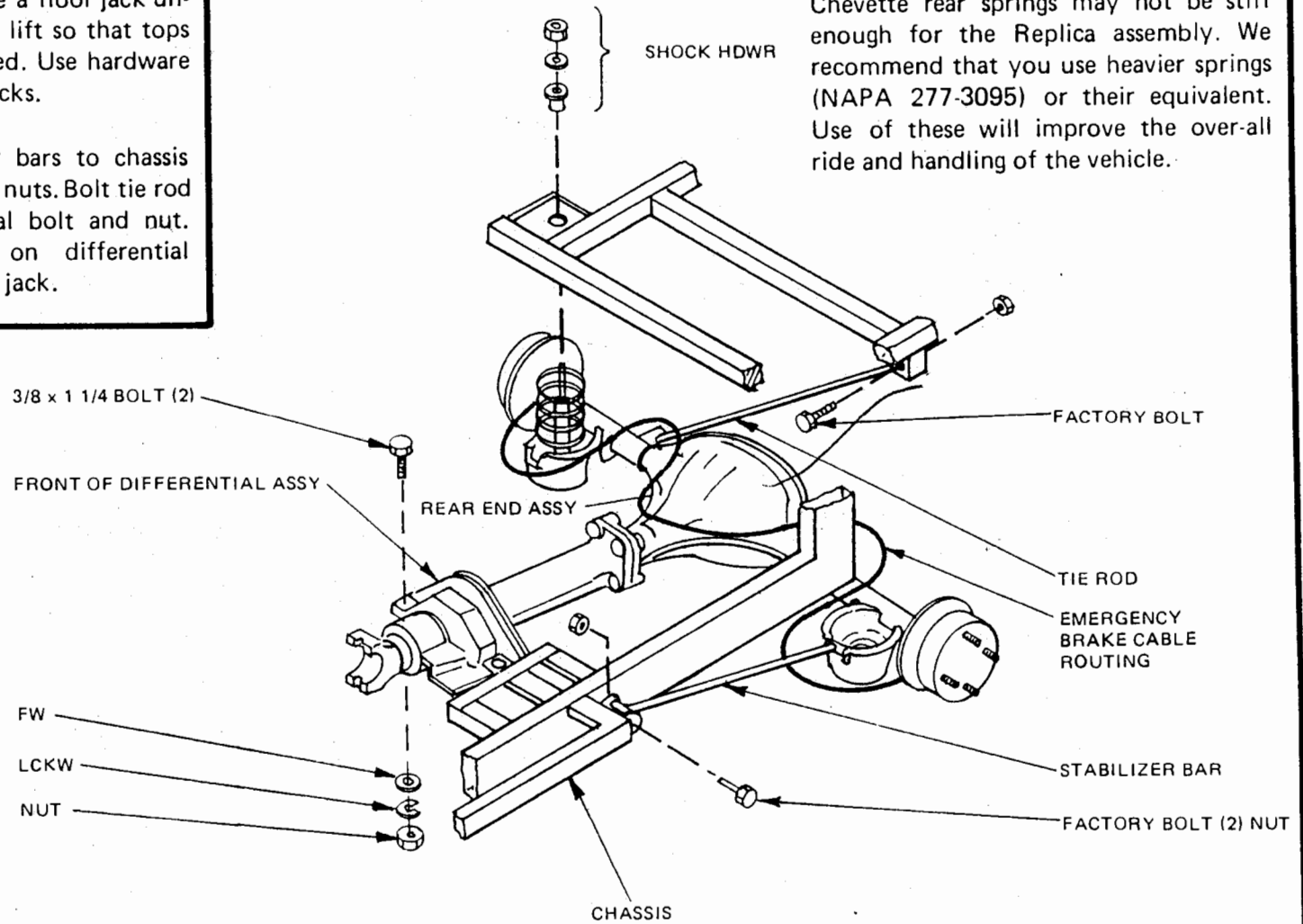

Figure 2

FRONT SUSPENSION

- The motor mount is unscrewed from the cross member by turning it counter-clockwise. This can be done by striking the octagonal bottom of the mount with a hammer and chisel.
- Measure 1" above cross member mounting hole and cut using a sabre saw and metal cutting blade. See Fig. 3 and Fig. 4, View A.
- Position assembly under chassis. Place floor jack under cross member and lift into position. Using original factory bolts, loosely bolt cross member to mounting plates on sides of chassis.
- Insert long factory bolts into hole below cut section of cross member (Figures 3,4) Secure with factory nuts. Finger tighten.

NOTE: This is a critical fit and some shifting of the cross member must be undertaken to allow the bolt to pass through the holes. Do not attempt to redrill the holes in the cross member or frame.

- Bring up rear of lower control arm and bolt into frame using original factory bolts and nut. Tighten all front end bolts to factory torque specifications.

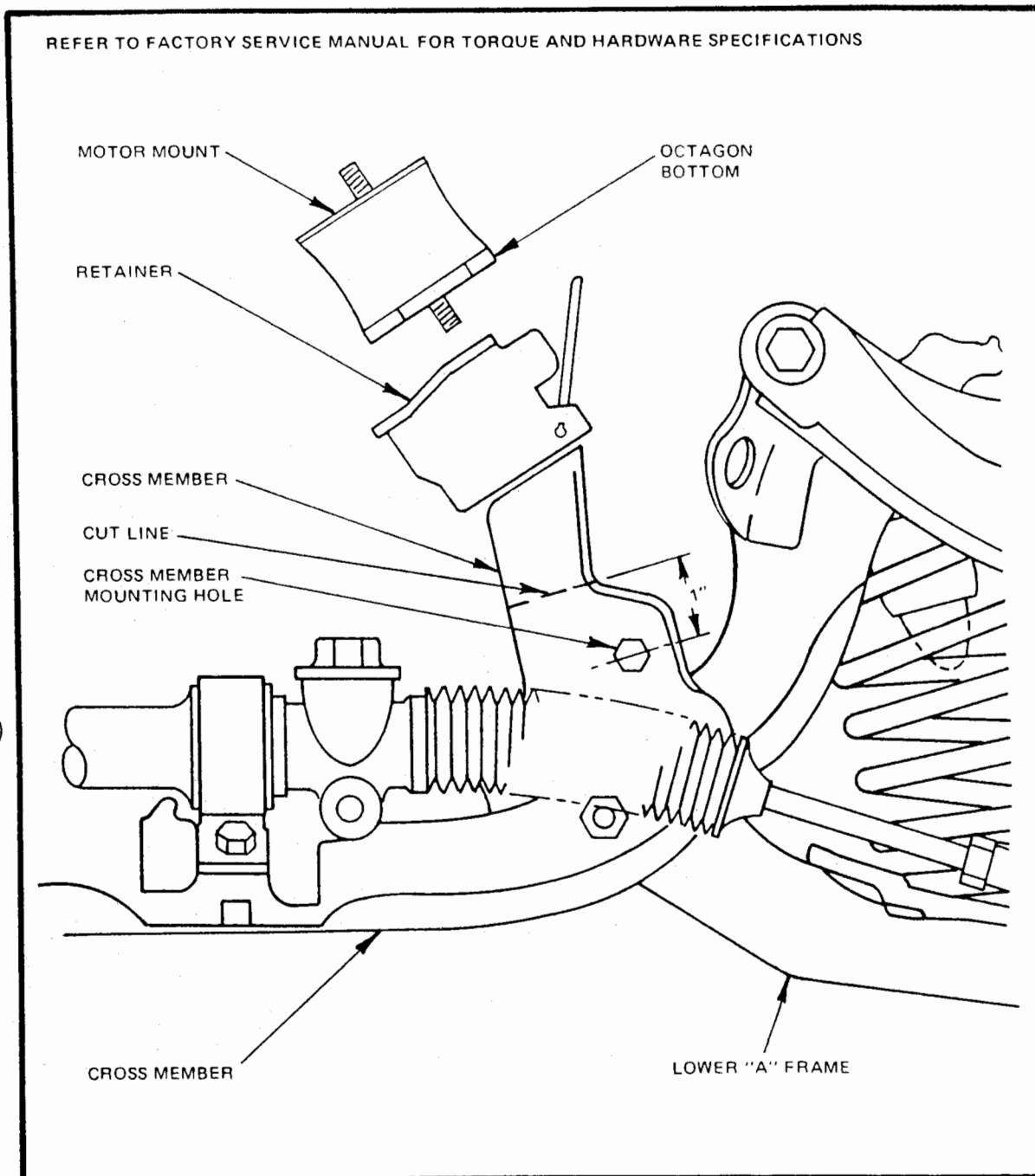

Figure 3

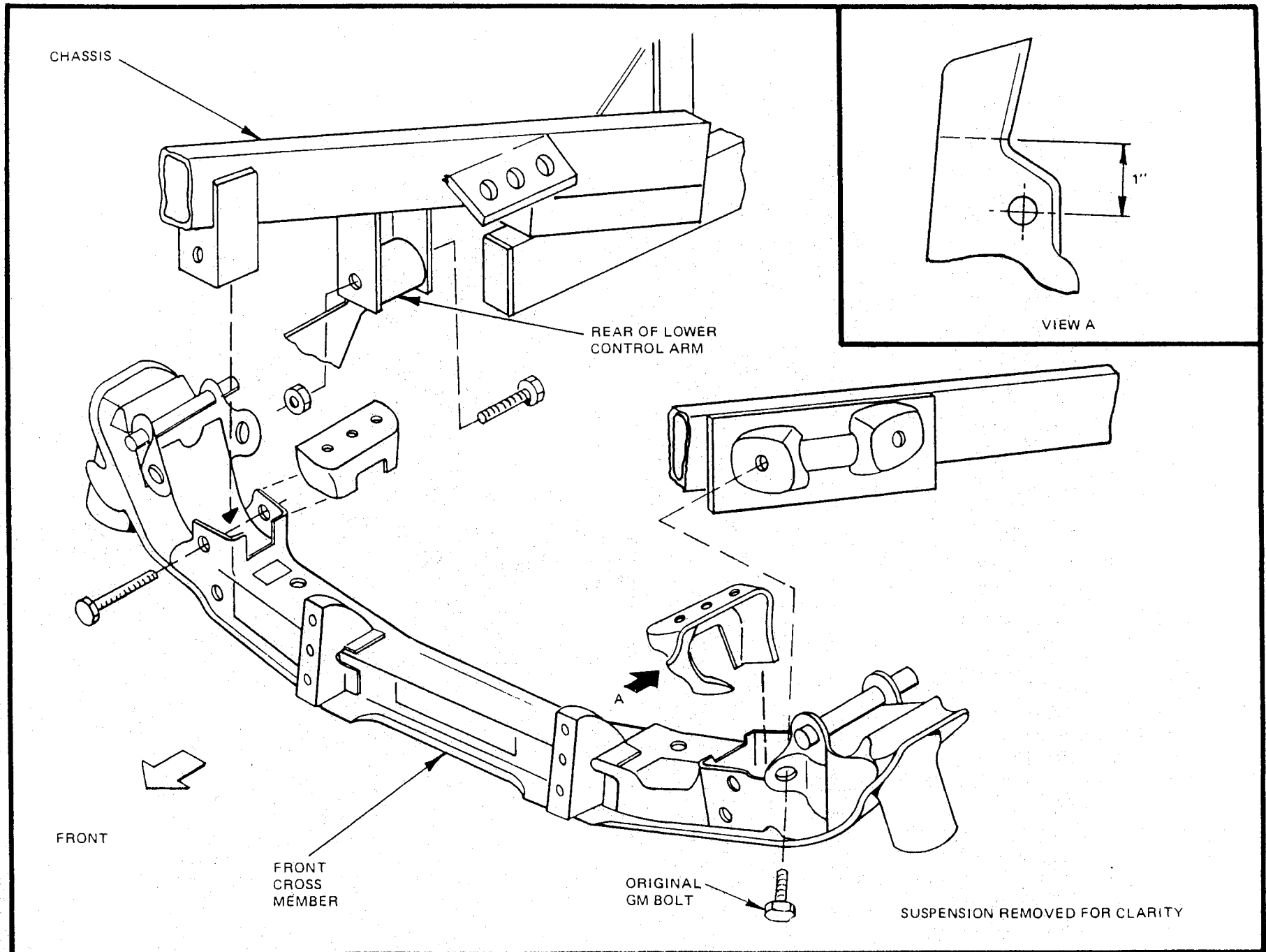
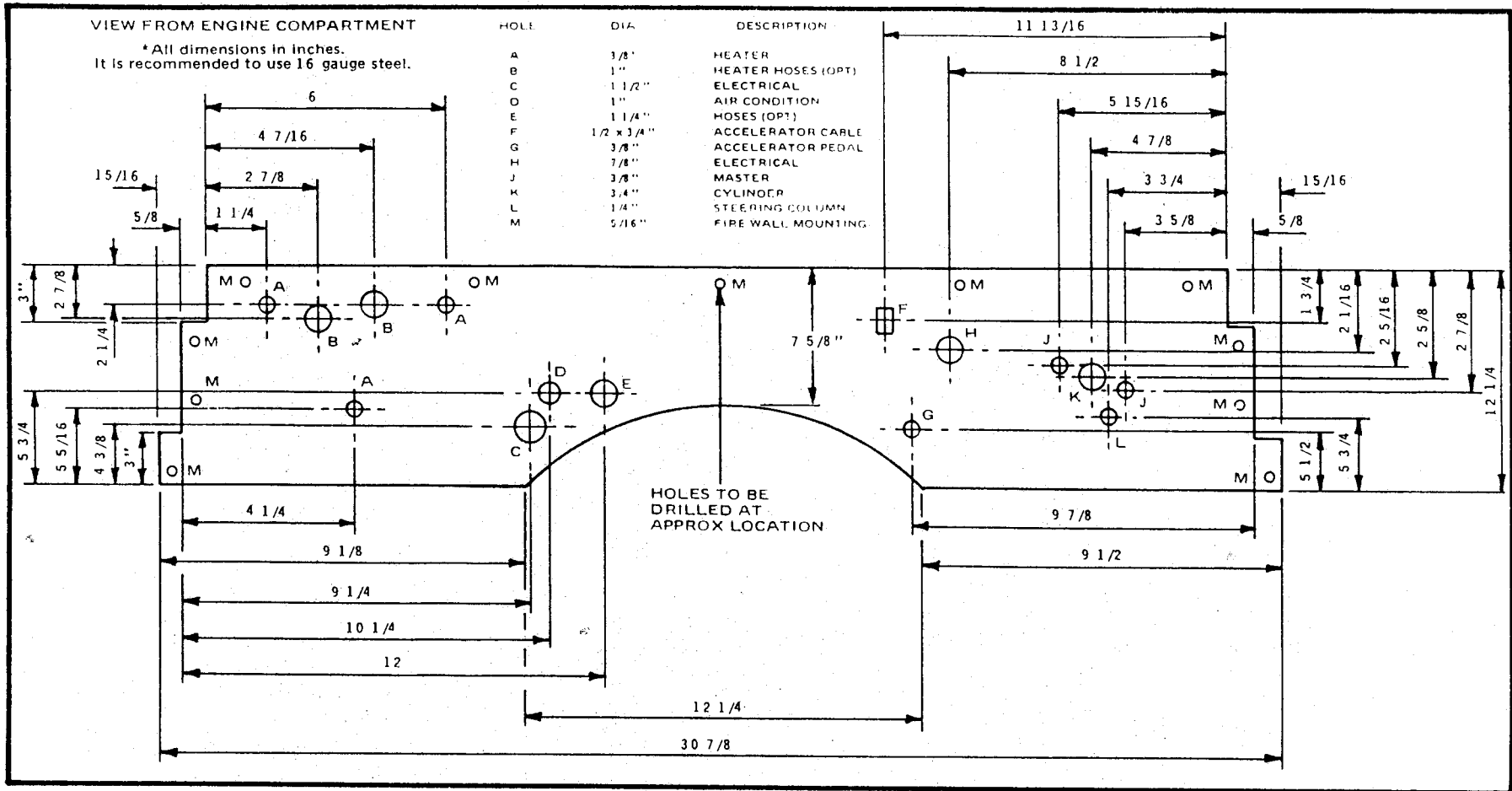

Figure 4



* Figure 5

FIREWALL

□ The firewall can be made from a variety of different materials. However, we strongly urge that you consider steel as your first choice because of its strength and fireproof properties. A steel firewall with all holes drilled, including those for the optional air conditioner and heater, is available as an option from our factory. If you should decide to fabricate your own refer to Figure 5 for dimensions.

□ Place firewall from the inside of the chassis against the back of the front upright frame members. (Refer to Figure 8). Mark hole locations on frame members. Remove firewall and paint with a good quality rust resistant black paint. Set aside and allow to dry. Drill 11 "3/16" holes through rear of frame uprights and secure firewall to frame with eleven 1/4 x 3/4" hex washer head self-tapping screws. Seal air spaces be-

tween firewall and frame with silicone sealer, or other suitable material.

NOTE: You may wish to drill hole for steering shaft in the firewall prior to mounting. (Refer to Figure 16) Mount upper portion of steering column temporarily using the steering shaft extension as a guide. Mark final hole location and cut a 2" hole in firewall with an appropriate hole saw.

MOTOR MOUNTS

- Install motor mounts and retainer to chassis using 10mm jam nut and 7/16" internal star lock washers. The open side of the retainer must face outwards and the small tab on the bottom of the retainer must engage one of the side holes.

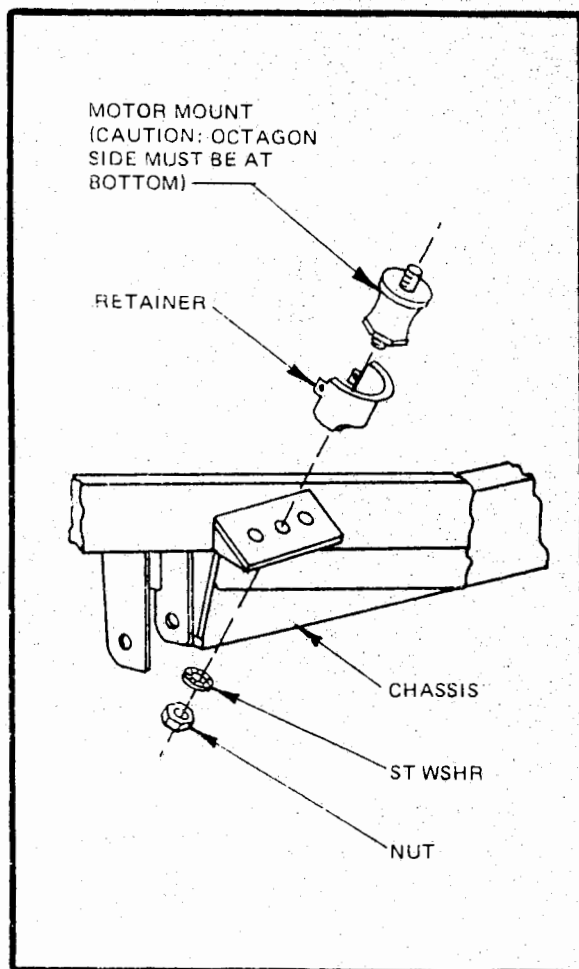

Figure 6

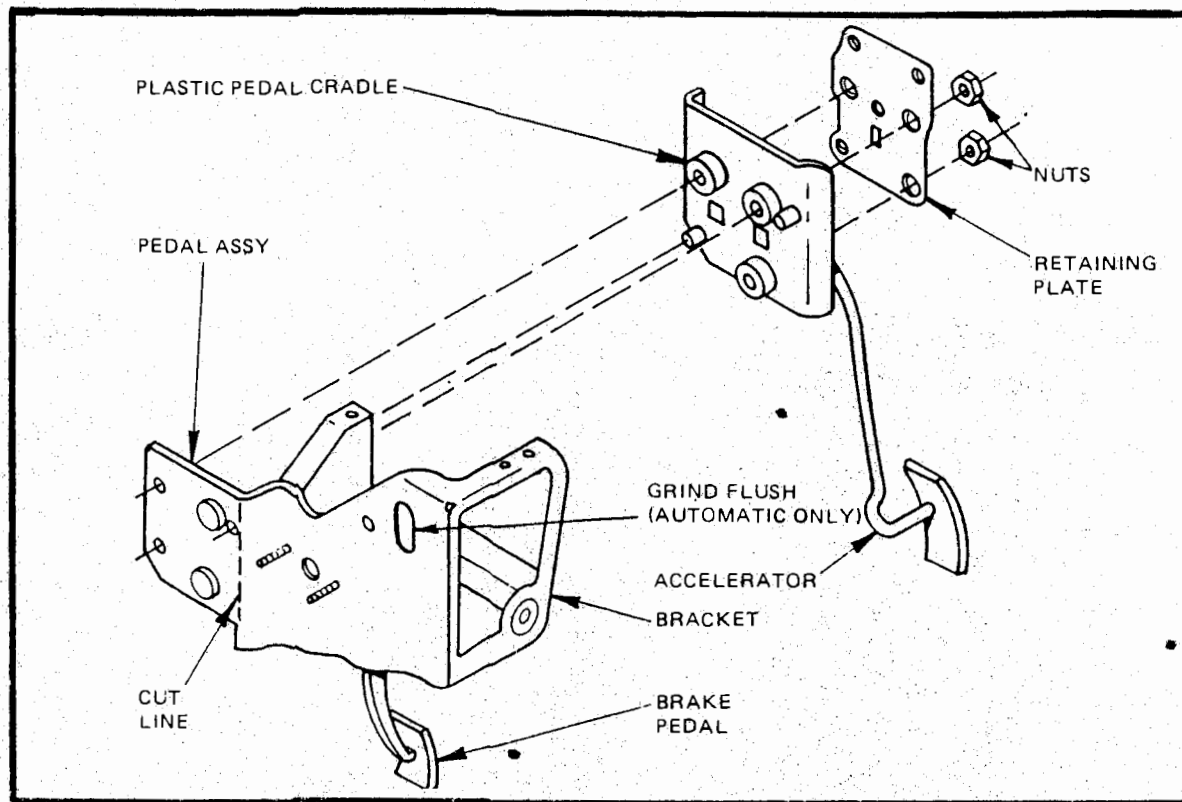

Figure 7

PEDAL AND MASTER CYLINDER

The pedal assembly must be modified as follows: Fig. 7.

- Remove the 2 nuts holding the accelerator pedal, retaining plate and plastic pedal cradle to bracket. (Figure 7) Cut bracket as indicated. Save all parts for later use.
- Fit spacer from brake master cylinder over two studs on pedal assembly. Fit entire assembly into firewall. Attach to chassis brackets using original factory bolts and nuts. Finger tighten.
- Slide master cylinder over studs protruding from fire wall. Secure with original nuts. Tighten chassis bracket bolts.
- Attach brake differential valve to fire wall support brace. Drill 3/8" holes at approximately the location shown and secure with 2 5/16 x 1" bolts with flat washer, lock washer and nuts. (Figure 8) Reattach brake lines to master cylinder.

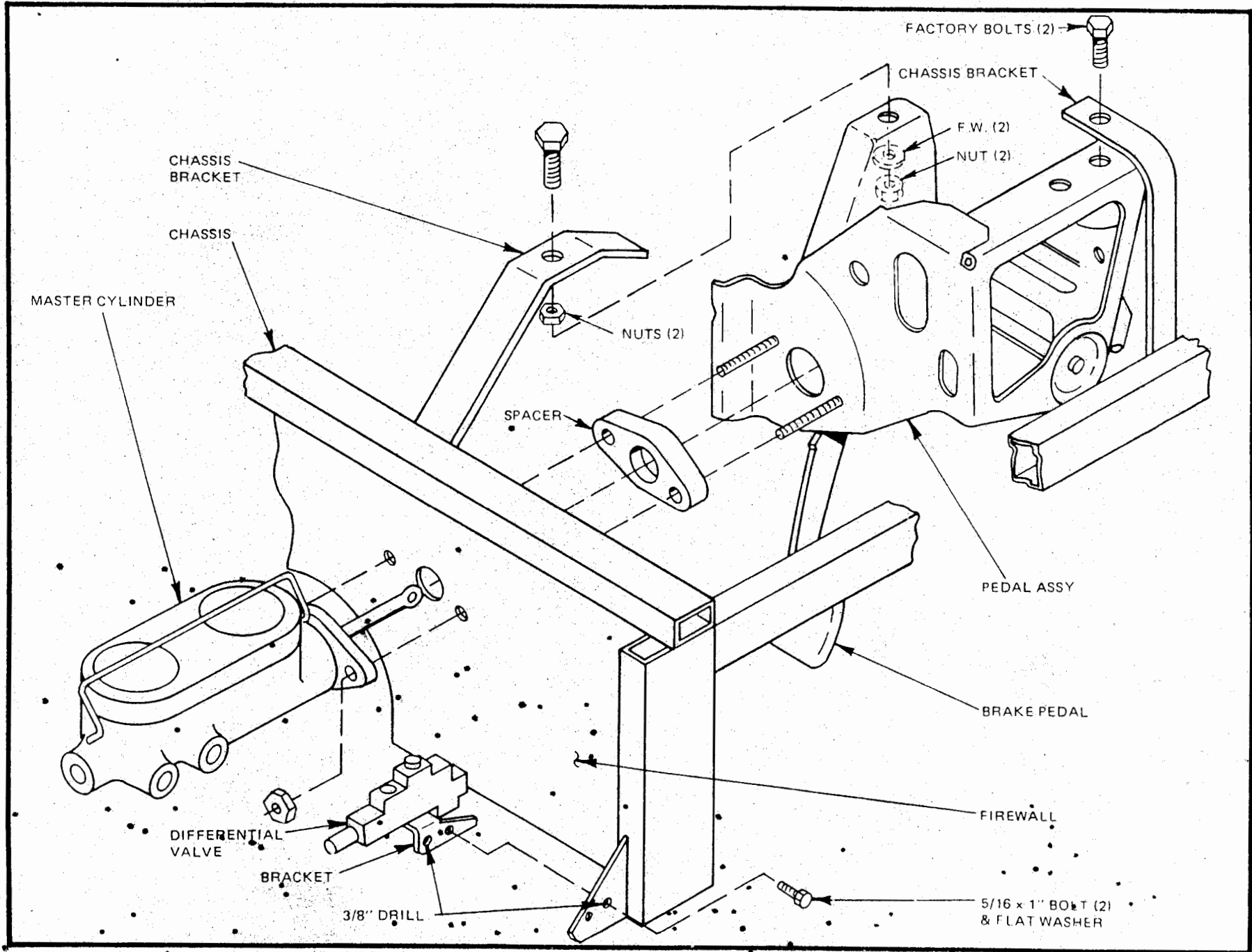

Figure 8

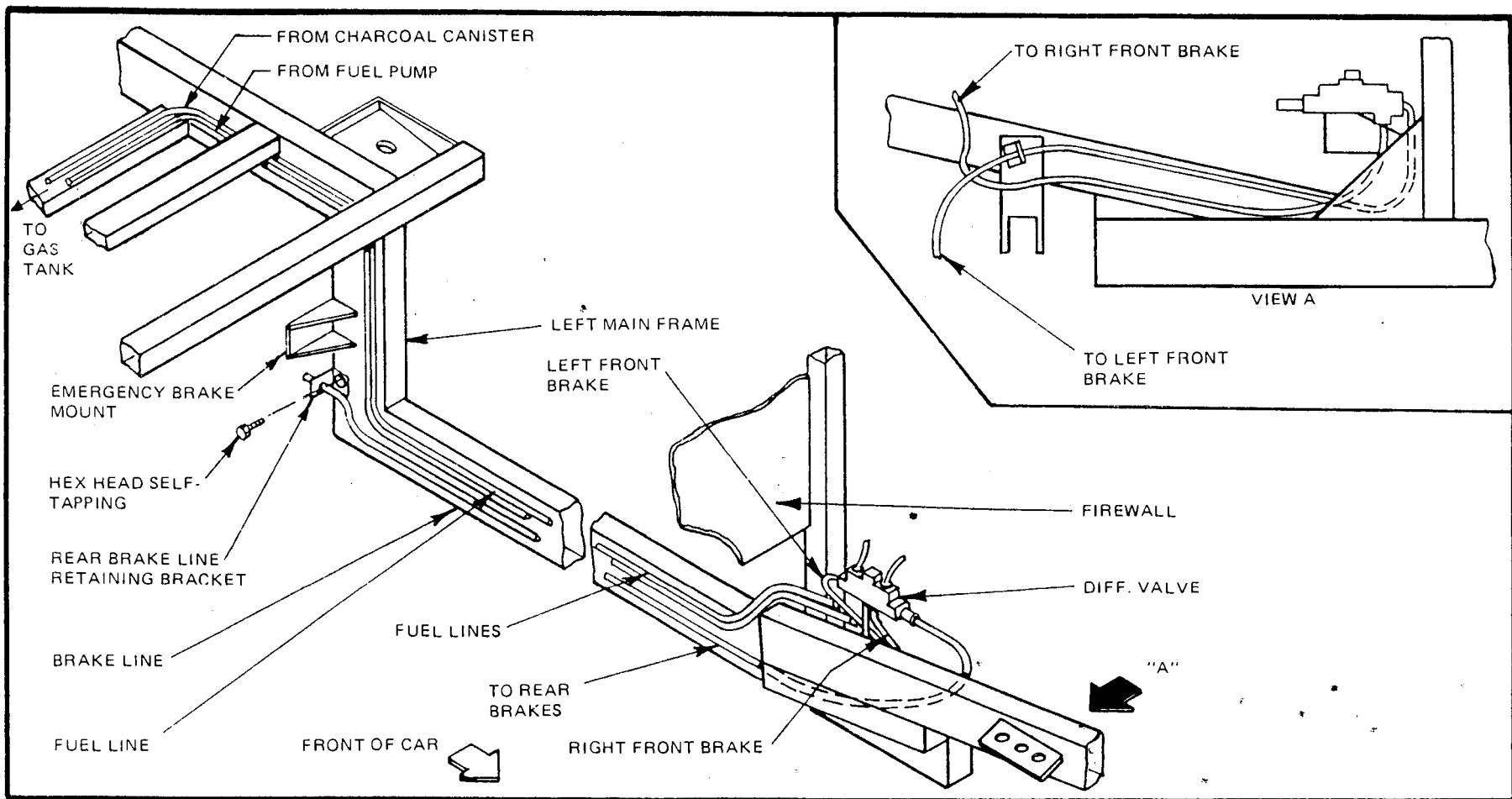

Figure 9

BRAKE AND FUEL LINES

- Brake and fuel lines can be removed from the Chevette and reused if they are in good condition. However, they will have to be straightened and a much better installation can be obtained by running new lines.
- All lines are routed along left main frame member and secured with clips removed from the Chevette.
- Attach rear brake line retaining bracket, removed from Chevette, to frame directly under the emergency brake mount. (Figure 9) Drill 1/4" hole and secure with 5/16 x 1" self-tapping bolt. Termination of lines should coincide with diagrams.
- Route right front brake line over frame and secure to cross member. Attach front brake hose mounts to frame just behind cross member. Drill 1/4" holes and secure with 5/16 x 1" self-tapping bolts. (Figure 9) Fill master cylinder with brake fluid and bleed system. Gas tank will be installed later after rear bumper brackets are attached. Fuel lines will be hooked up then.

ENGINE INSTALLATION

- Bolt transmission support to transmission using original hardware. Finger tighten. Lower engine into car, slipping transmission under firewall. Continue to lower engine until motor mounts are seated in engine brackets. Using a floor jack, raise transmission until support contacts bottom of frame. Bolt using $5/16 \times 1 \frac{1}{4}$ " bolts, with flat washers, lock washers and nuts. Bolt engine to motor mounts using original hardware. Tighten all bolts.

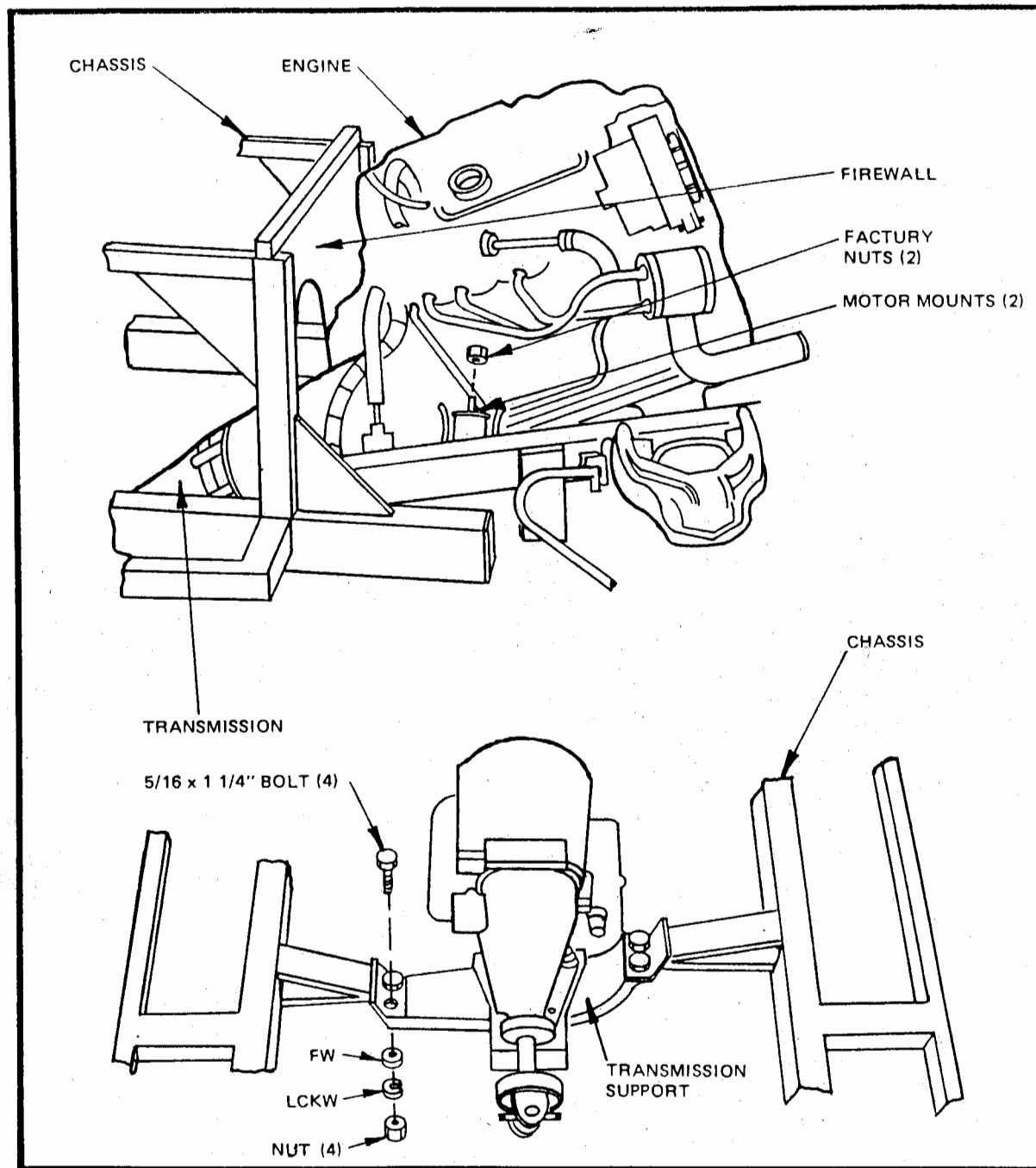

Figure 10

FRONT SPRINGS

- Remove front springs as follows:

- Disconnect rack and pinion from wheel. Secure chassis on jack stands under frame. Place a floor jack under wheel assembly and compress spring. Use additional weight on front end if necessary. Loosen upper ball joint nut about halfway. Do not remove. If ball joint will not work free, rap on side of wheel assembly with a hammer to free it. Do not strike threaded portion. Remove nut and slowly lower wheel assembly until spring is free. If spring should get stuck use a rubber mallet or screw driver to free it. (Figure 11)

- Cut 1 full coil off of the bottom of spring. You will have to use a special carbide saw blade or have it cut with a torch. Reinstall in car by jacking up wheel assembly until ball joint stud can be seated. Install new nut and tighten. (Figure 11) Wheels and tires can now be installed to give a rolling chassis.

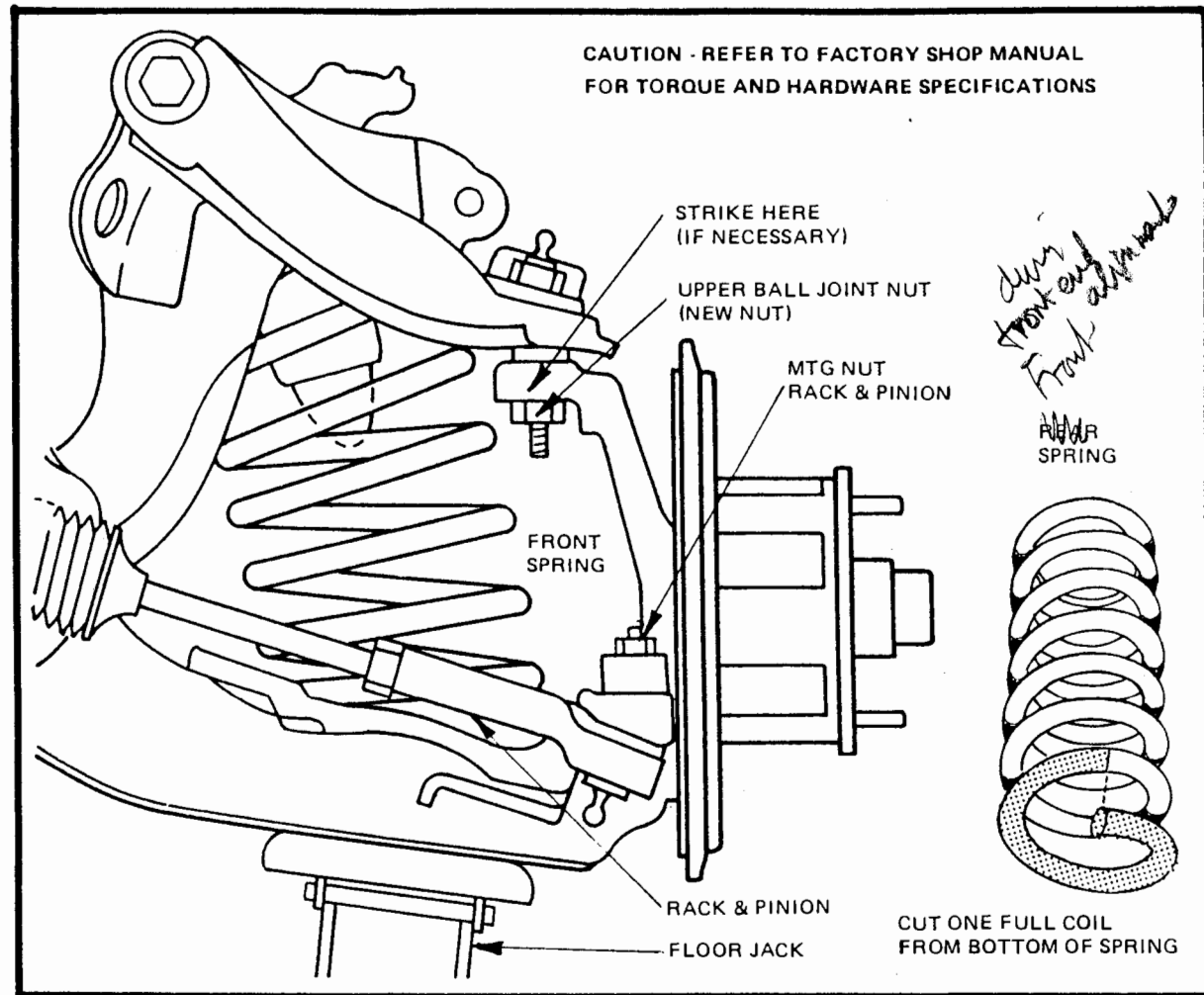

Figure 11

FRONT SHOCK MOUNTING

Because of the configuration of the Replica assembly the original shocks cannot be used. They can be replaced with NAPA 2067 or a commercial equivalent. We use a custom shock designed specifically for the weight and handling characteristics of the Chevette Replica, and it is available as an option. To adapt front suspension, modify as follows:

- Fit lower shock mount onto lower "A" frame, as shown, keeping bottom of mount on flange of "A" frame. Adjust mount until a 7" measurement is obtained from the lower "A" frame mounting bolt to the outside edge of the shock mount. Mark and drill through front part of lower "A" frame, 5/16" drill bit.

- With the shock mount in place spray a short burst of black spray paint through the holes in the bracket and the holes drilled in the "A" frame. Remove shock mount and drill through the paint spots on the rear part of the "A" frame. Secure with 8 bolts, 5/16 x 1 1/4", with lock washer and nuts. Install shocks using hardware provided with shocks. **Note:** If necessary trim shock bushing for fit.

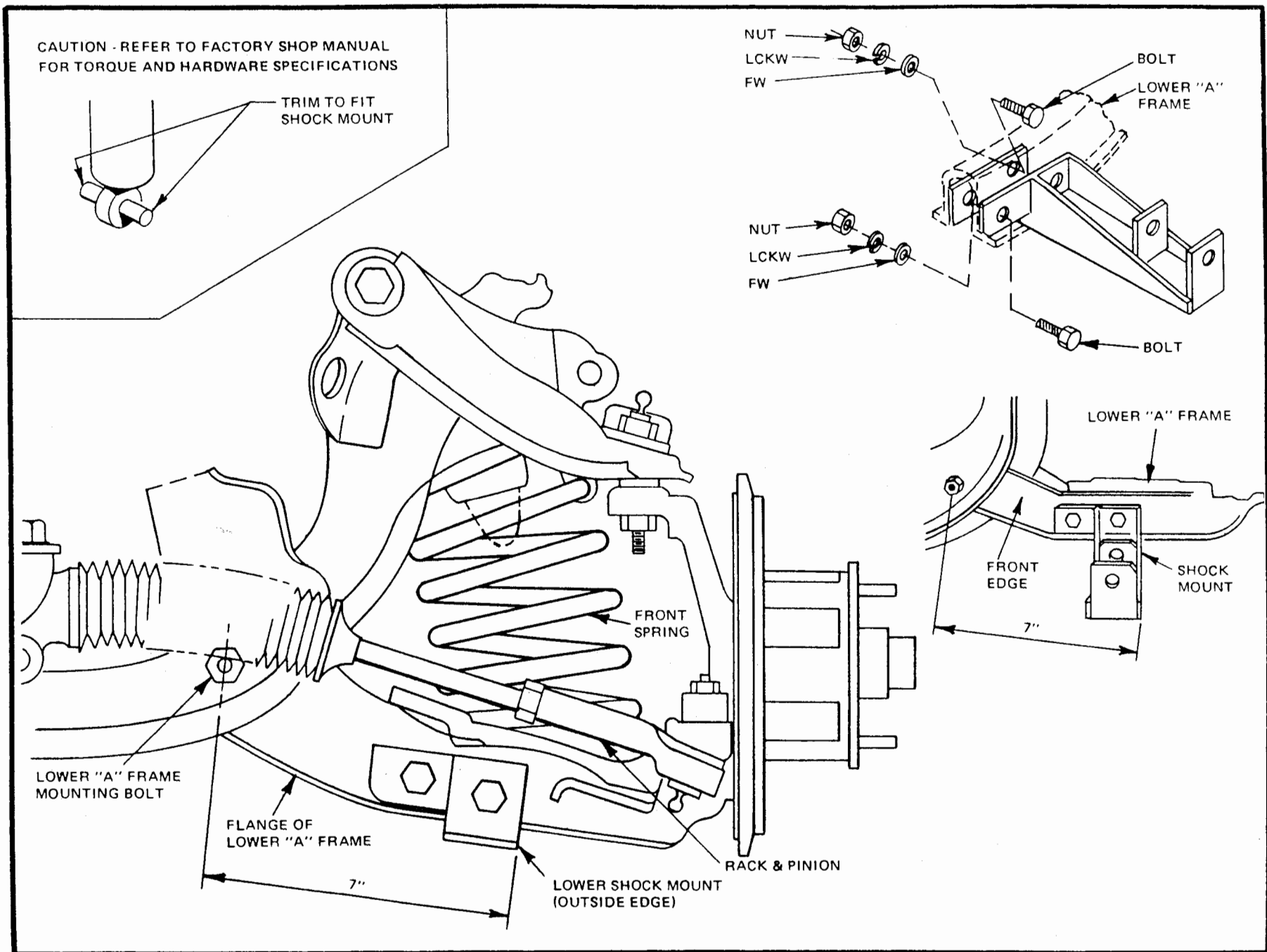

Figure 12

GAUGE SENDER INSTALLATION (IF USING OPTIONAL GAUGES)

TEMPERATURE SENDER

- Remove the 4 bolts holding the fan blades to the hub. Remove the plastic timing belt cover from the front of the engine. Disconnect the wire from the Chevette sender and remove the sender from the block. Replace with temperature sender supplied with gauges. Remove connector from wire and discard. Attach wire to sender.

PRESSURE SENDER

- The Chevette pressure switch is located on the left side of the engine just under the intake manifold and above the starter. It must be retained in the new assembly.
- Fabricate an extension "tee" fitting using a 1 1/2" length of heavy steel tube with 1/4" NPT threading on each end and a 1/4" "tee" fitting. Remove the Chevette sender using a 1 1/16" 6 point deep socket. **NOTE:** This is supplied with the custom gauges.
- Screw the extension pipe into the block. Attach the original Chevette sender to one side of the "tee" fitting and the sender supplied with the gauges to the other.

EXHAUST SYSTEM

This operation requires some welding. Read completely before starting.

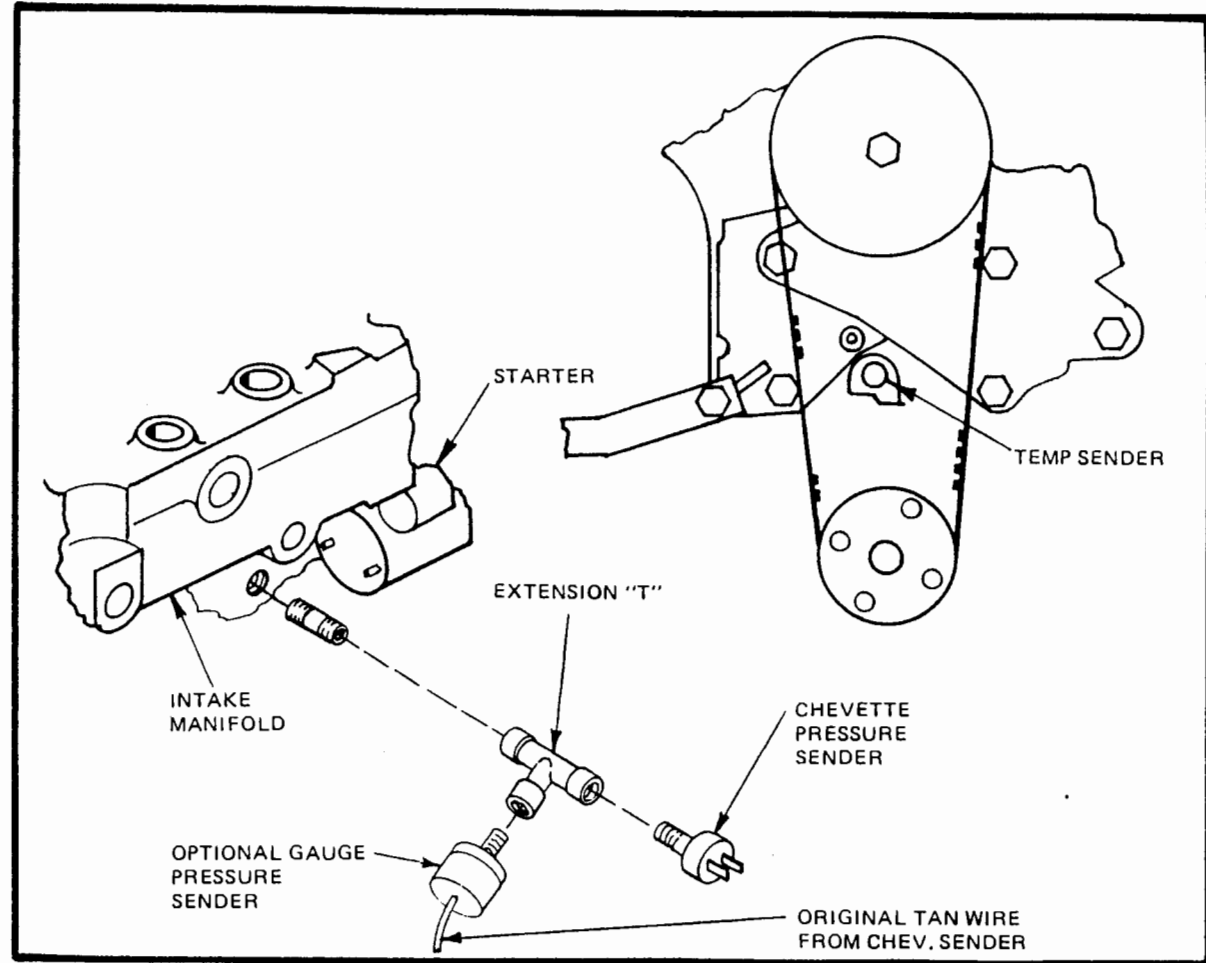

Figure 13

If your system is showing signs of rust or corrosion you may want to have a muffler shop fabricate an entirely new system to fit the Replica. If this is the case, attach exhaust system up as far as catalytic converter and proceed to next section. The finished car can be driven to a muffler shop and the remainder of the system fabricated.

NOTE: Before disassembling or cutting muffler system scribe lines on all pipes and

components to assure correct alignment during reassembly.

- Because of the configuration of the frame, the stock muffler cannot be used. To replace, proceed as follows:
- Cut original muffler out, 1" from muffler on each side. Cut the connecting pipe, running from catalytic converter to muffler, down to 12".

EXHAUST SYSTEM (CON'T)

- Obtain replacement muffler Q.T. mini-turbo muffler No. 65-1814 or equivalent. (3 1/2 x 6 x 18") with staggered inlet and outlet.
- Attach headpipe, with catalytic converter attached, to exhaust manifold of engine. Secure catalytic converter bracket to transmission bracket using factory bolts.
- Attach connecting pipe to catalytic converter. Align previously scribed marks. Fit new muffler in place and weld to connecting pipe. **NOTE:** If welding equipment is not available, you can align all pieces and mark them. The entire unit can then be removed and taken to a welder to be joined.)
- Remove original hangers from tail pipe. Fit into place and weld to muffler.
- Secure to tail pipe bracket on frame using 2 1/4" muffler clamp.
- The rear of the tail pipe is suspended from a strap type hanger (1 3/4" pipe). Loosely attach to tail pipe and find best position for securing hanger to frame. Bolt using 1/4 x 1" bolt with flat washer, lock washer and nut. Tighten clamp. (Figure 14)

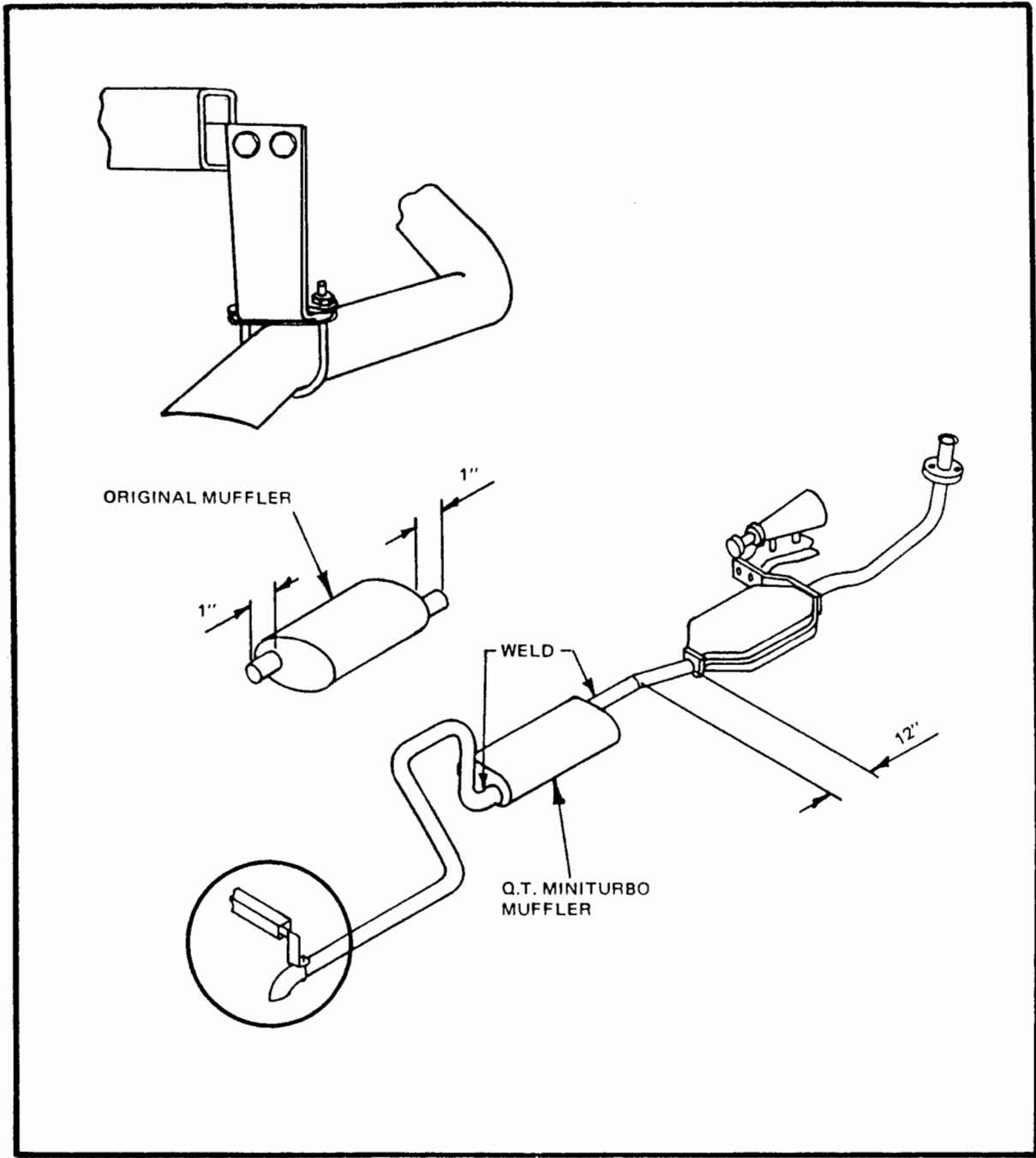

Figure 14

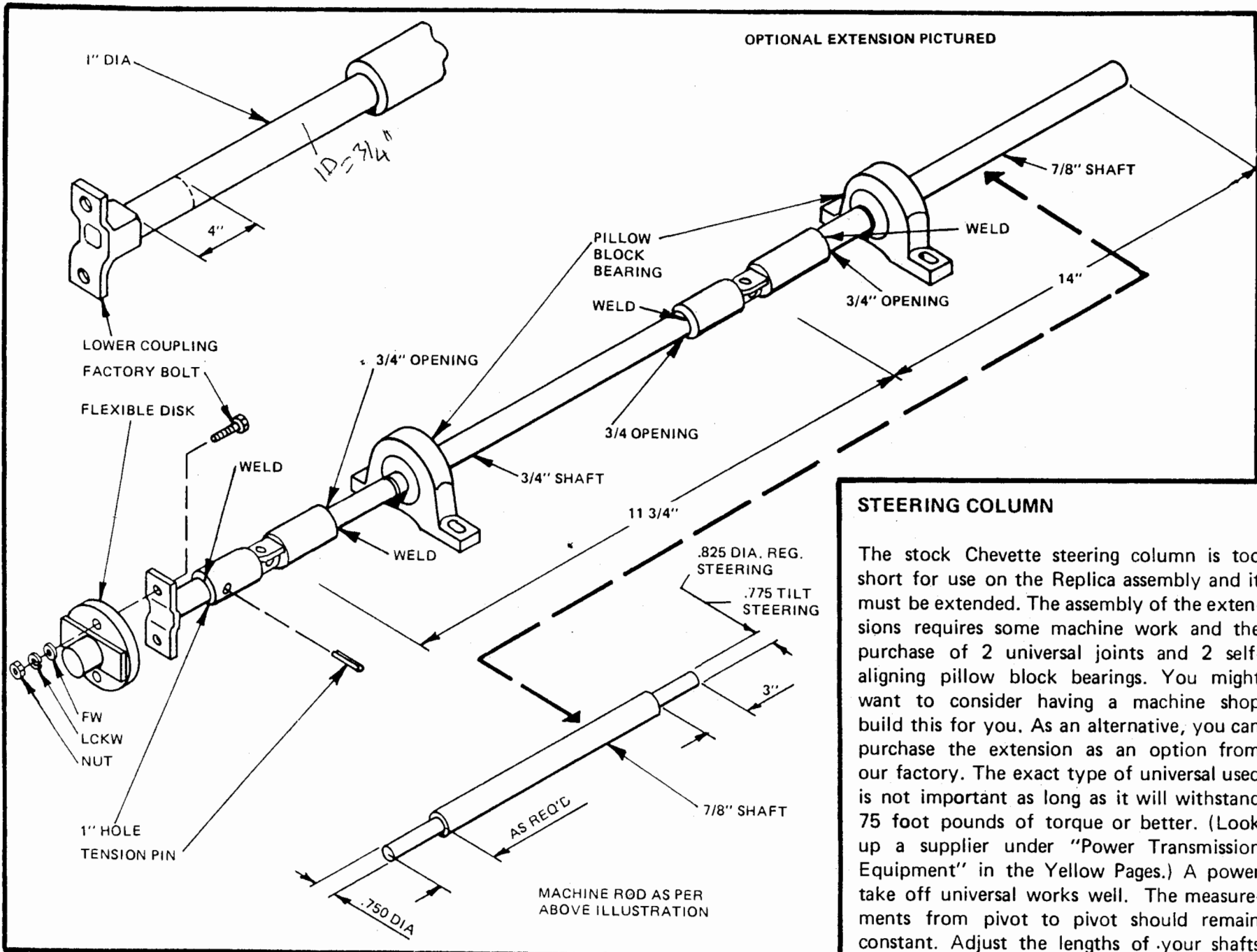
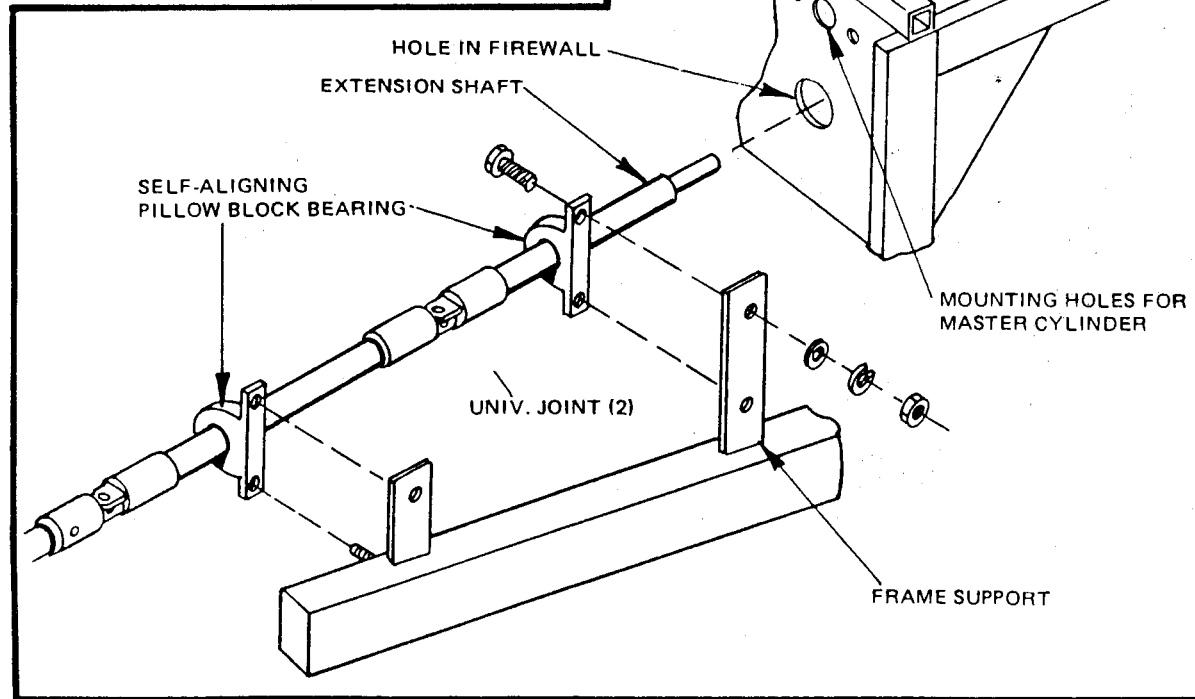
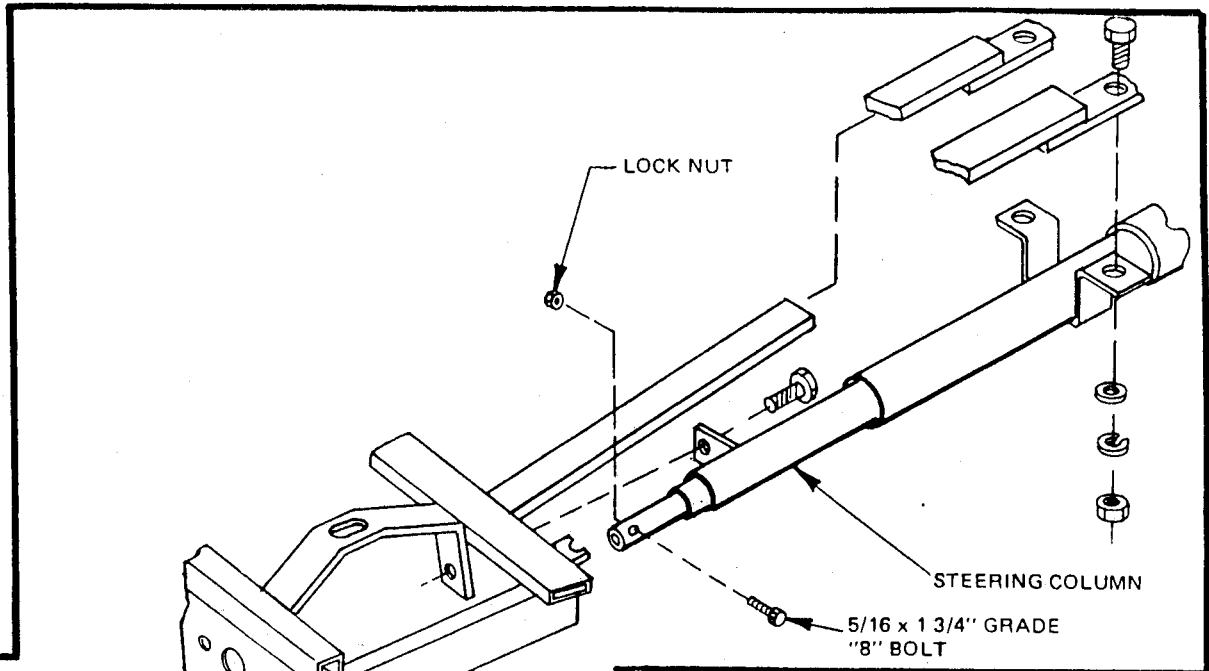

Figure 15

- Measure 1 1/2" back from the lower coupling on the hollow steering shaft. Cut with a hack saw or saber saw. Cut an additional 2" off of the shaft and discard.
- Insert the lower coupling into the 1" hole on the end of the extension. Drill 11/32" hole completely through the universal and the shaft and secure with a 3/8 x 1 3/4" heat-treated steel spring tension pin. (These are available at the machine shop where the extension was assembled.) Weld all joints.
- Bolt lower coupling with extension attached to flexible disk on rack and pinion.



- Slide steering column through hole in firewall and over extension shaft. Loosely bolt to frame, using 3/8 x 1 1/2" bolts with flat washer, lock washer and nut.
- Align pillow block bearings with supports on frame. Mark hole locations and drill 3/8" holes. Bolt to brackets using 3/8 x 1 1/2" bolts. Secure with flat washer lock washer and nut. Drill through hollow shaft of steering column and through extension with 5/16" drill bit. Secure with a 5/16" x 1 3/4" grade "8" bolt with lock nut and weld joint. Tighten steering column bolts.

NOTE: Have front end properly aligned by a professional with the proper equipment. Have tires and wheels high speed balanced. Lube all bearings and joints.

Figure 16

AIR CONDITIONER (OPTIONAL)

Because of the size of the unit, the stock Chevette air conditioner system is unsuitable for use on the Replica assembly. These instructions cover our optional air conditioner unit.

- Install air conditioning compressor in accordance with instructions provided with the unit.
- The evaporator blower unit is attached to the frame under the dashboard. Mount the evaporator blower unit to the brackets located on the frame (Fig. 17) with the hardware provided with the air conditioner.
- The condenser unit is attached to the radiator bracket. The hose connection should terminate on the right side with the larger opening on top. See "Radiator Installation" for correct bracket orientation.
- Position it in the bracket and drill through any 4 of the pre-stamped holes and into the bracket (5/16" drill). Secure with 1/4 x 1 1/2" bolts with flat washer, lock washer and nuts. (Figure 17) Hook up hoses when radiator bracket is installed.

NOTE: If using optional air conditioning unit, the alternator must be remounted to driver's side and the fan belts changed. These parts are furnished with the air conditioning unit.

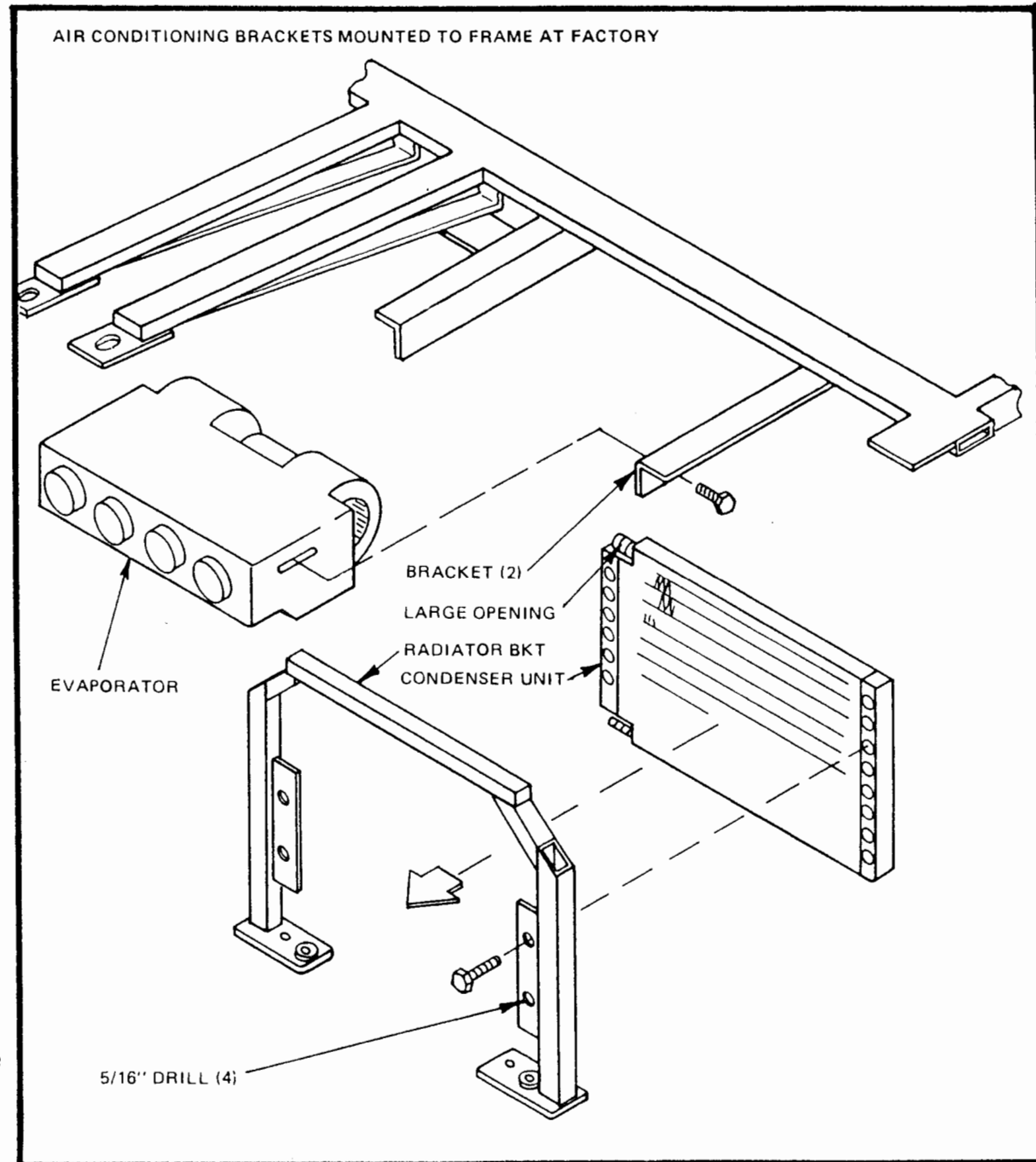

Figure 17

RADIATOR

- Position the radiator bracket on the frame as shown. Make sure the side with the spacer washer, welded closest to the upright, is on the driver's side. Place the radiator bracket $3/4''$ from frame on passenger side. Check fan clearance to radiator hoses, then mark hole locations and drill. ($3/8''$ holes)

- Secure through holes without spacers using $5/16 \times 1 \ 3/4''$ bolts with flat washer, lock washer and nut. Finger tighten. Position original Chevette radiator supports over spacers and secure with $5/16 \times 2''$ bolts with flat washer, lock washer and nut. Tighten all bolts.

- Position radiator in place on supports and fit Chevette top plate to radiator. Align edge of top plate with forward edge of bracket. Mark hole locations. Drill $5/16''$ hole and secure with $5/16 \times 1 \ 1/2''$ bolts with flat washer, lock washer and nut.

- Reconnect all radiator hoses and transmission lines to radiator.

NOTE: The standard Chevette radiator hoses are too short and must be replaced. Use a universal hose for the top, NAPA FM 47 or its equivalent - $23 \ 1/2''$ long.

- The transmission cooling lines also must be extended for proper clearance. Purchase $2 \ 1/2'$ ($30''$) of $5/16''$ neoprene fuel hose. Cut in half and replace existing rubber hose(s).

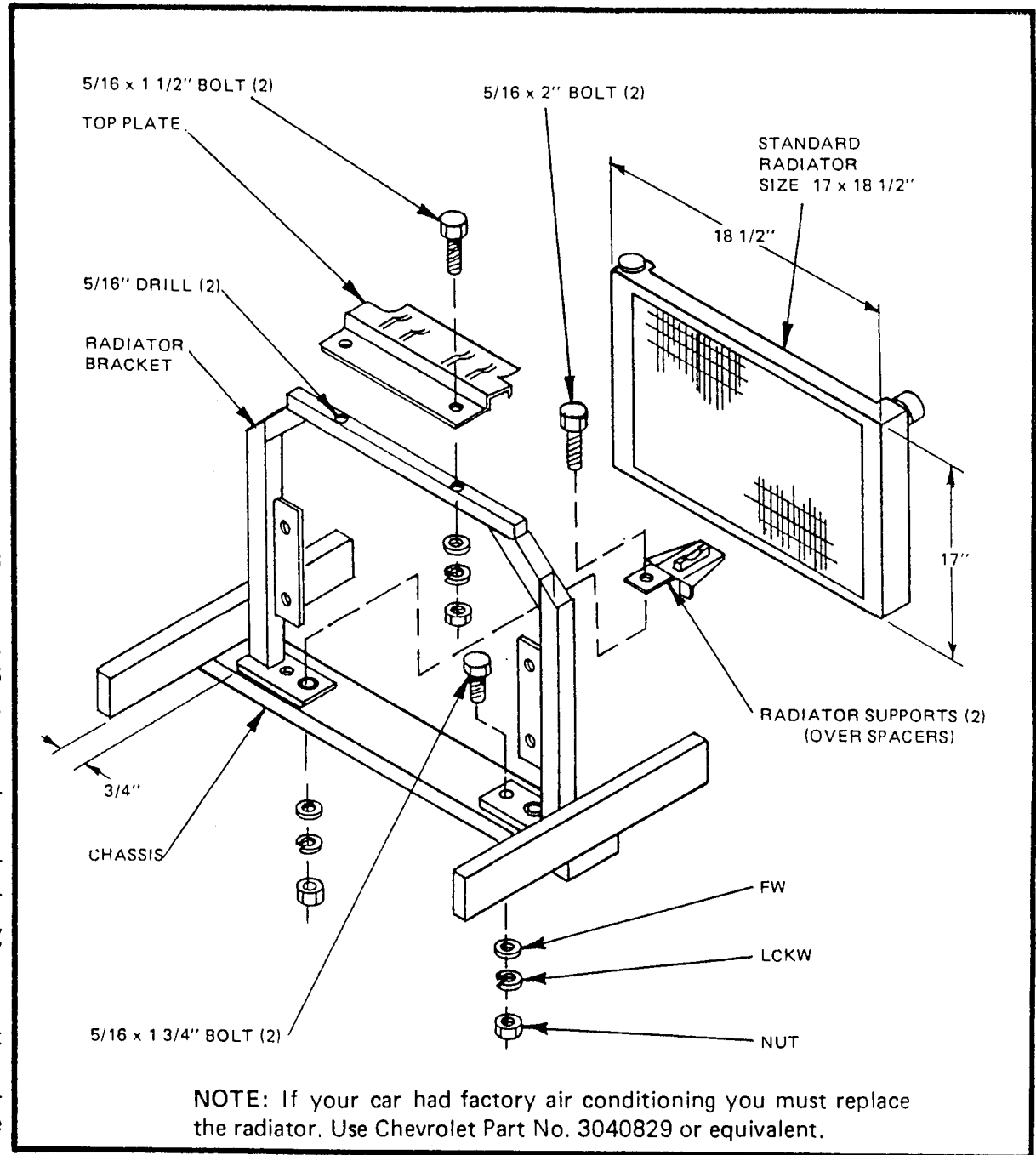

Figure 18

DRIVE SHAFT SHORTENING

NOTE: Drive shaft should be shortened by a professional drive shaft shop. After shortening the drive shaft should be balanced. If the drive shaft is not properly balanced, the car may exhibit vibrations at speed.

- After the engine is installed, measure the distance between the transmission housing and the rear universal joint. Subtract one inch from this distance to allow for spline motion.
- Take the shaft to a professional drive shaft shop or machine shop equipped to do the work and balance the finished shaft.

If you elect to do the work yourself, here are the steps required:

- Scribe a reference mark along rear of drive shaft so that U-joint yoke can be reinstalled in the same relative position.
- Cut through the drive shaft at the rear weld joint between the casing of the U-joint yoke at the rear end of the assembly.

CAUTION: Do not cut all the way through; cut only through the outer tubing.

- Shorten the drive shaft tube to the required length.

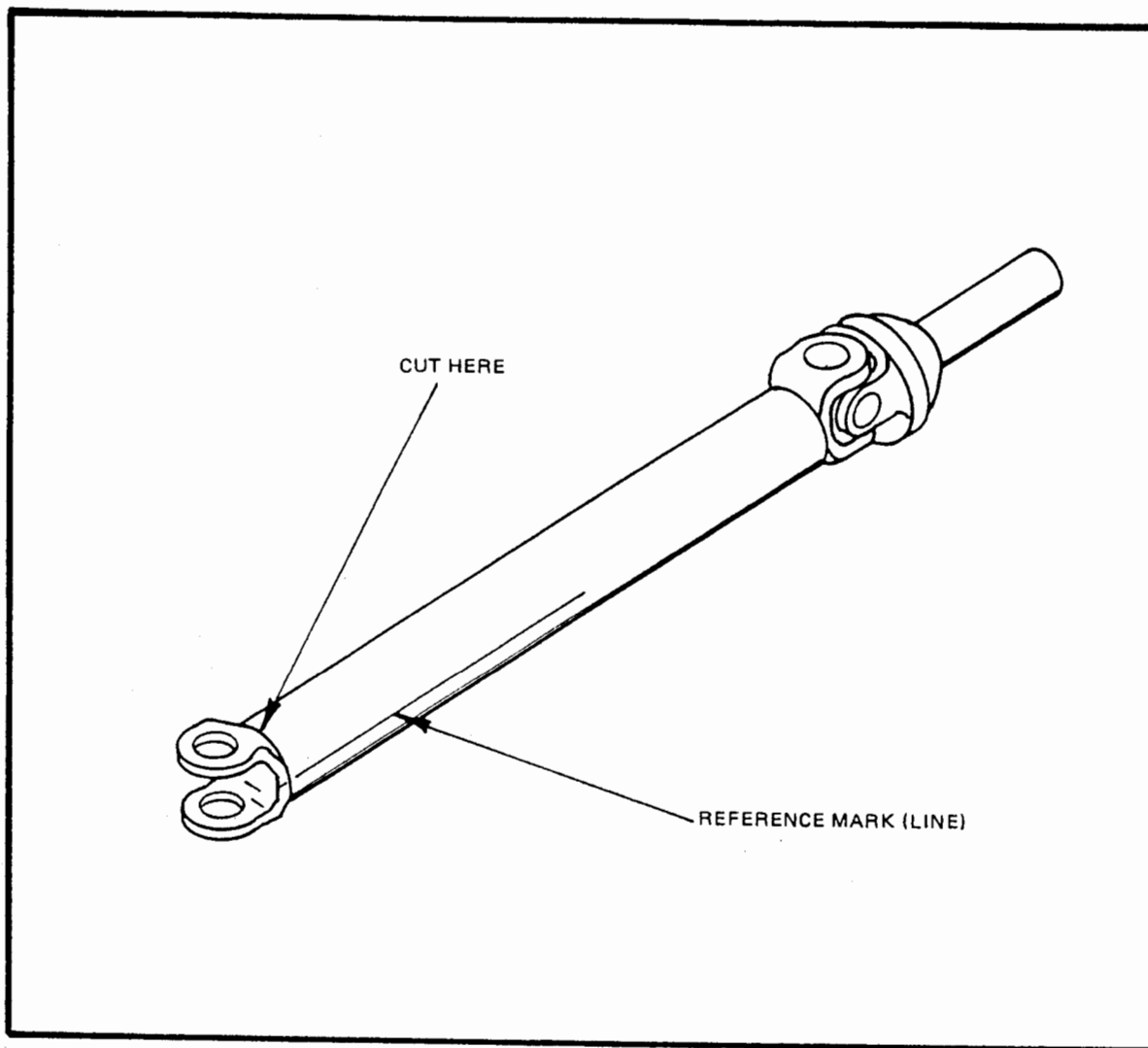
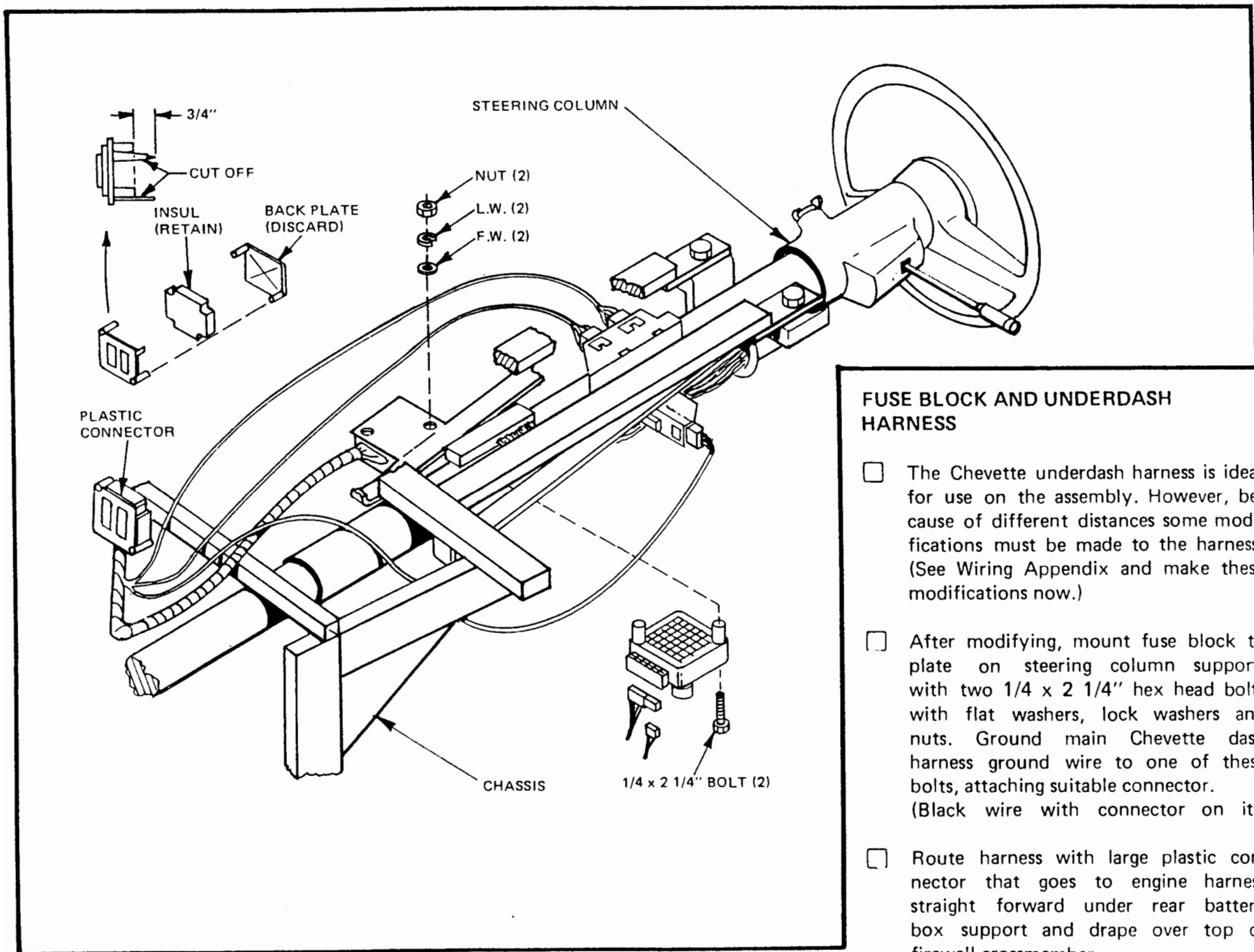

Figure 19

- Position the U-joint yoke back into the end of the drive shaft tube and align with scribe mark.
- Weld U-joint yoke to shortened drive shaft tube.

CAUTION: The universal joint centers must be kept in line.

- Rebalance the drive shaft by welding tabs as appropriate to obtain proper balance.



FUSE BLOCK AND UNDERDASH HARNESS

- The Chevette underdash harness is ideal for use on the assembly. However, because of different distances some modifications must be made to the harness. (See Wiring Appendix and make these modifications now.)
- After modifying, mount fuse block to plate on steering column support, with two 1/4 x 2 1/4" hex head bolts with flat washers, lock washers and nuts. Ground main Chevette dash harness ground wire to one of these bolts, attaching suitable connector. (Black wire with connector on it.)
- Route harness with large plastic connector that goes to engine harness straight forward under rear battery box support and drape over top of firewall crossmember.

Figure 20

BATTERY BOX AND COMPUTER

- A battery box similar to the one illustrated must be fabricated, if desired, or our factory has an optional fiberglass unit available.
- The large plastic connector from underdash harness mounts on the front far right (passenger side) of the raised area of the battery box on the engine side. (Figure 21)
- Cut slot for wires in the lip of the battery box, as shown in figure 21. Mount plug to box with two $1/4 \times 1\ 1/2$ " hex head machine screws with flat washers, lock washers and nuts. Seal area around cut-out. Apply weather stripping foam $1/4 \times 3/4$ " to top of frame where it contacts the battery box. It will be permanently installed later when the body is mated to the chassis.
- Fabricate a bracket similar to the one shown, or order from our factory, to support engine computer (if fitted on your Chevette). The computer is located directly under the battery.
- Route computer plugs through hole in firewall and connect.

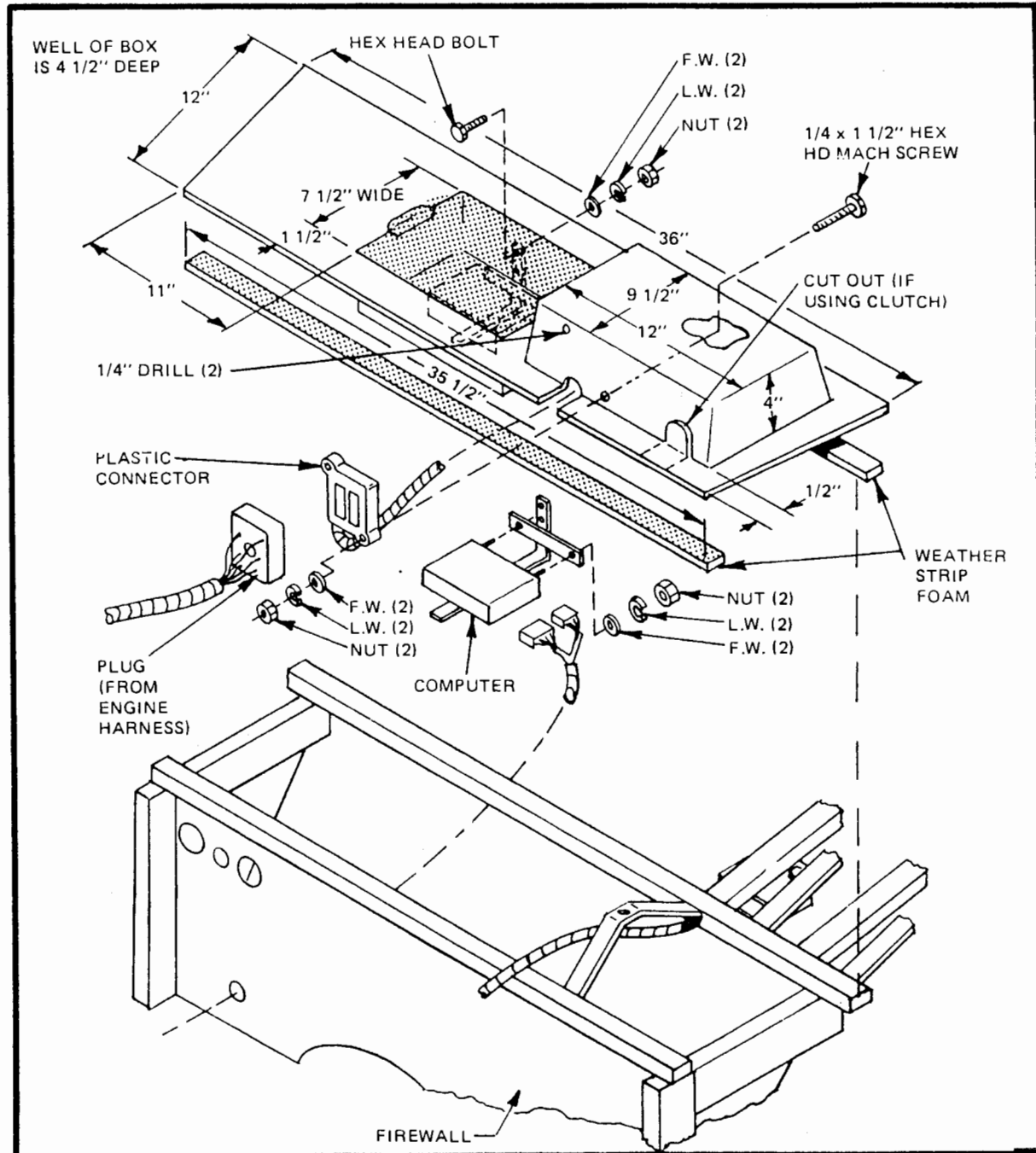

Figure 21

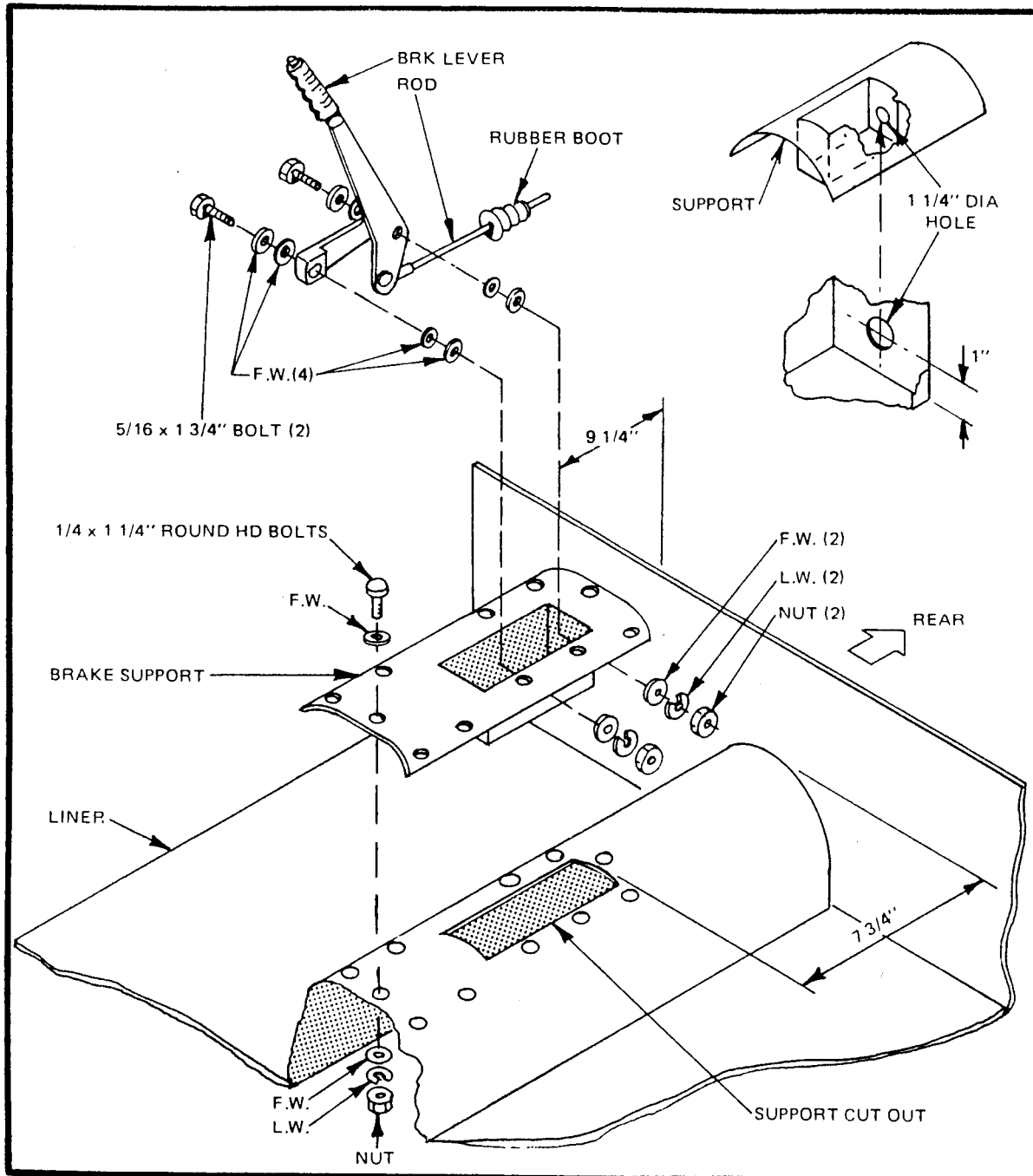

Figure 22

INTERIOR LINER

- Cut out the depression in the interior liner for the gear shift lever. It may be necessary to further trim the area for a good fit. Mark hole locations and drill 5/16" holes. Center of shift lever rear mounting holes measures 32 1/2" from back of liner. Bolt using 5/16 x 1" hex head bolts with flat washer, lock washers and nut. (Figure 23)
- Measure 7 3/4" from rear of liner and mark. This is the back edge of support cut out. Place back of support cavity on this line and trace rectangle from cavity on liner. Cut out liner with a sabre saw. Cut a 1 1/4" hole in the back of the brake lever support. (Figure 22)
- Bolt brake lever to emergency brake support using 5/16 x 1 3/4" bolts with flat washer, lock washer and nuts.
- Fit the support into the liner. Adjust until the center of the rear mounting bolt is 9 1/4" from rear of liner. Check all clearances with emergency brake switch mounted. Drill 12 holes around perimeter of the support (1/4" drill bit). Secure with 1/4 x 1 1/4" round head bolts with 2 flat washers, lock washer and nut. (An alternative to bolting is to use 3/16" pop rivets. Re-install rubber boot that came off the Chevette using epoxy or silicone to hold it in place.
- Glue down strips of rubber matting or weather strip foam to the top of the frame where it will contact the interior liner. This will prevent squeaks in the finished car.

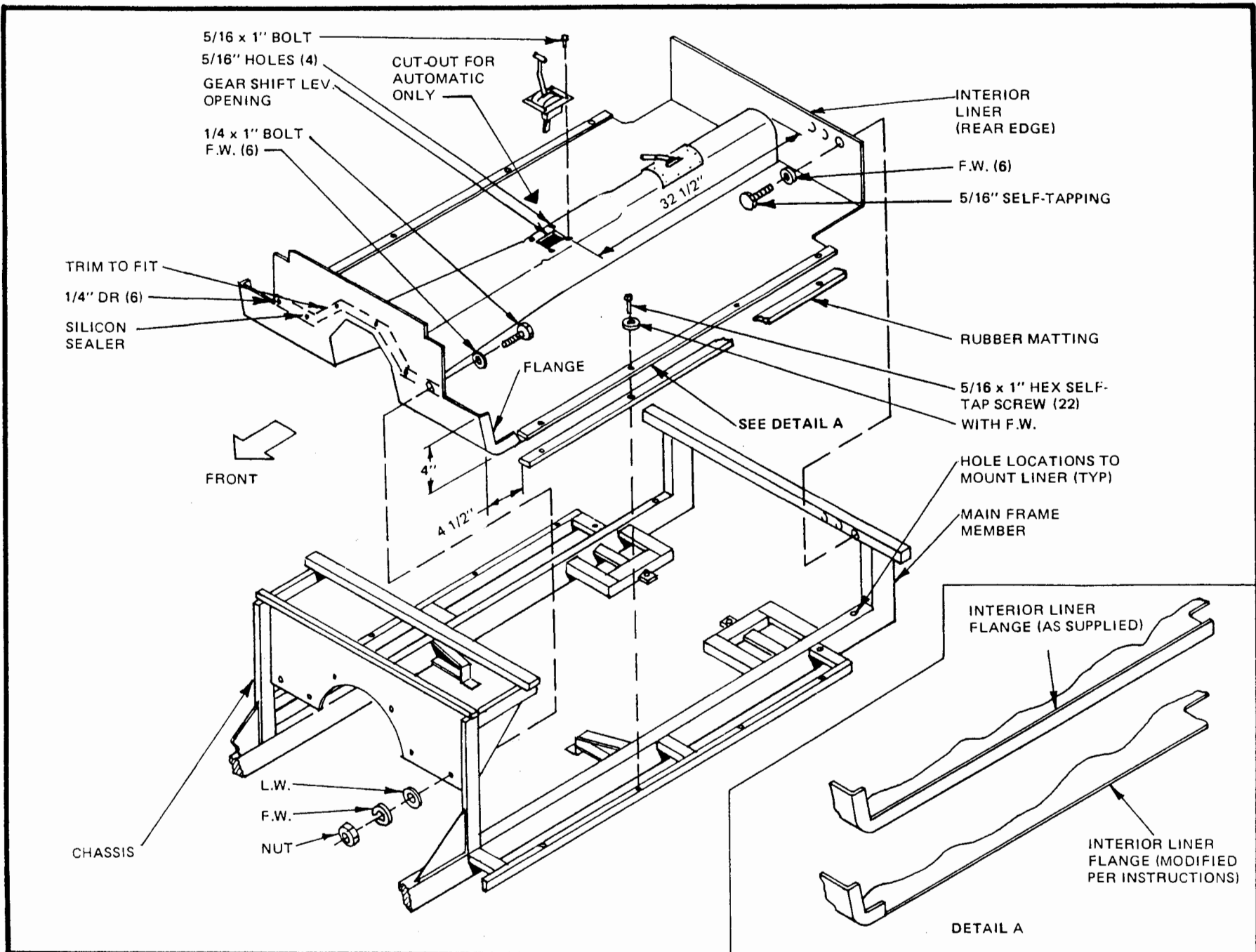

Figure 23

- Fit liner onto chassis trimming the corners as necessary to clear steering column hole, heater holes, frame support braces, etc. Trim side lip off both sides of liner. (Figure 23) Glue rubber matting or weather stripping where liner contacts frame. Apply silicone sealant to the edge of the liner where it contacts the firewall. With the liner in place, drill 8 holes through each side of liner and top of frame. (Use 1/4" drill. See diagram for hole locations. Also drill 6 holes across rear of liner. Secure liner to frame with 22 hex head 5/16" self-tapping screws with flat washers. Drill 6 holes 1/4" through liner and firewall and bolt using 1/4 x 1" bolts, flat washers and nuts. (Note: Pop rivets may be used to secure liner to frame in place of self-tapping screws.)

EMERGENCY BRAKE CABLES

Because of the shorter distance from the emergency brake lever to the rear wheels, the pre-formed ends on the brake cables are not used. In addition, the mounting brackets must be reversed.

- Pry the retainer off the cables and reverse the mounting brackets. Reinstall the retainer on the cables.
- Bolt brackets to frame using 5/16 x 1 1/4" bolts with flat washer, lock washer and nuts.
- Refit cable cradle to threaded rod of handle, with longer of the two cables in the cradle. Install retainer nut, leaving 1/2" of rod visible behind nut.

- Attach the two cables using (2) 1/8" cable clamps, available in most hardware stores. (Figure 24)
- Fabricate a small bracket to hold the emergency brake return spring.

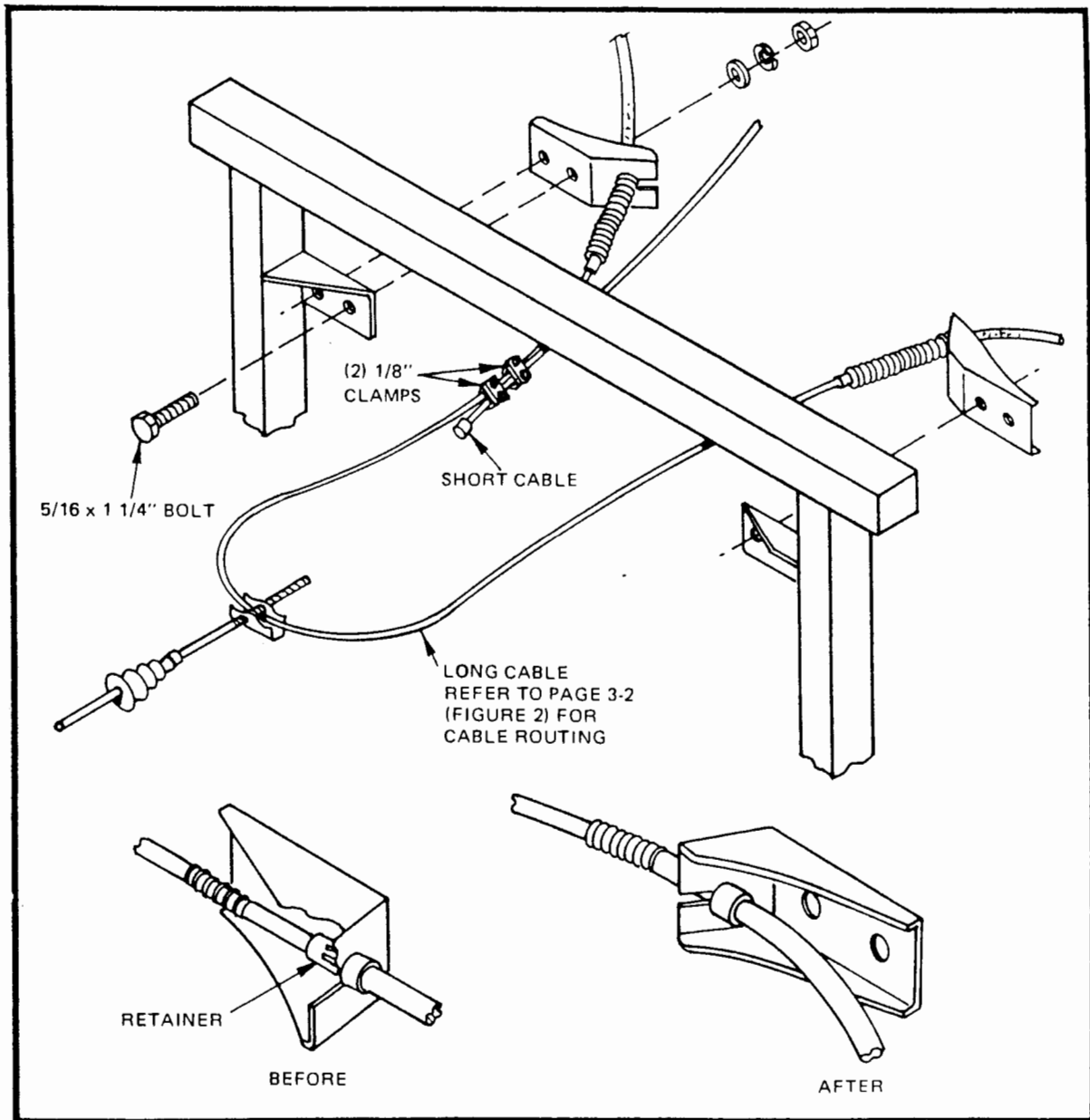
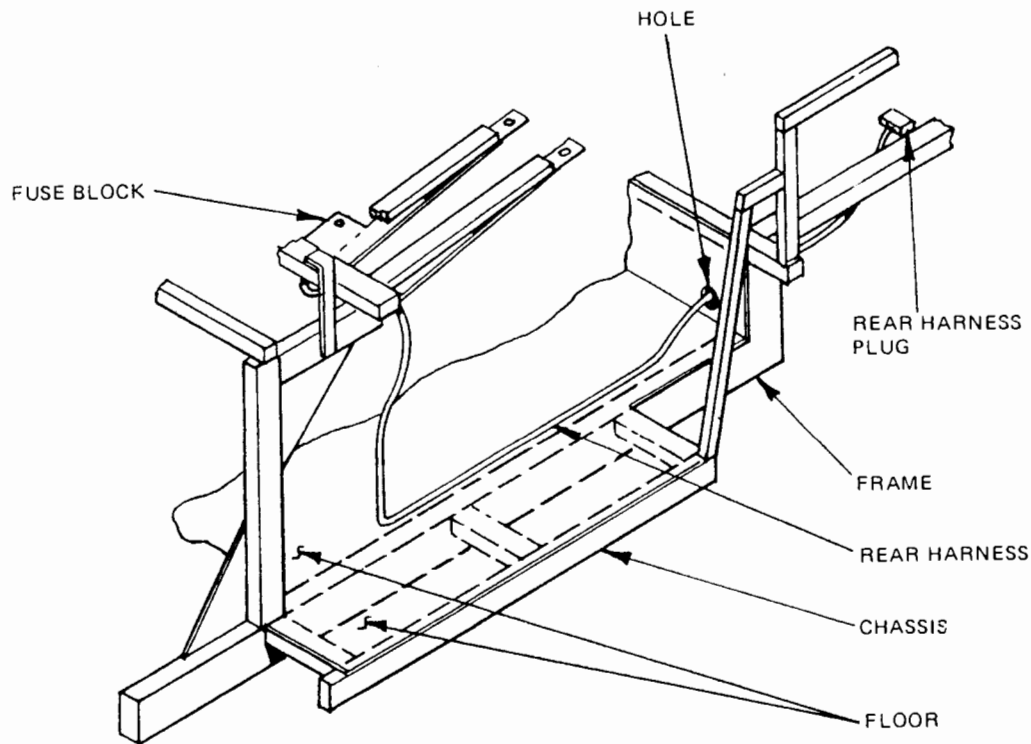

Figure 24



REAR HARNESS RUN

- Plug the rear harness cable back into the fuse block.
- Route rear harness over steering supports and down left side of car. Run along floor next to door. Cut hole in rear of floor and pass wires through. These will be connected to rear lights during final assembly.
- Connect steering column connectors to their original plugs or sockets. Make sure all wiring clears steering shaft, brake and accelerator pedals and cables. Secure with connectors. Secure diagnostic connector to left steering column lower support brace. Use wire ties wherever necessary.

Figure 25

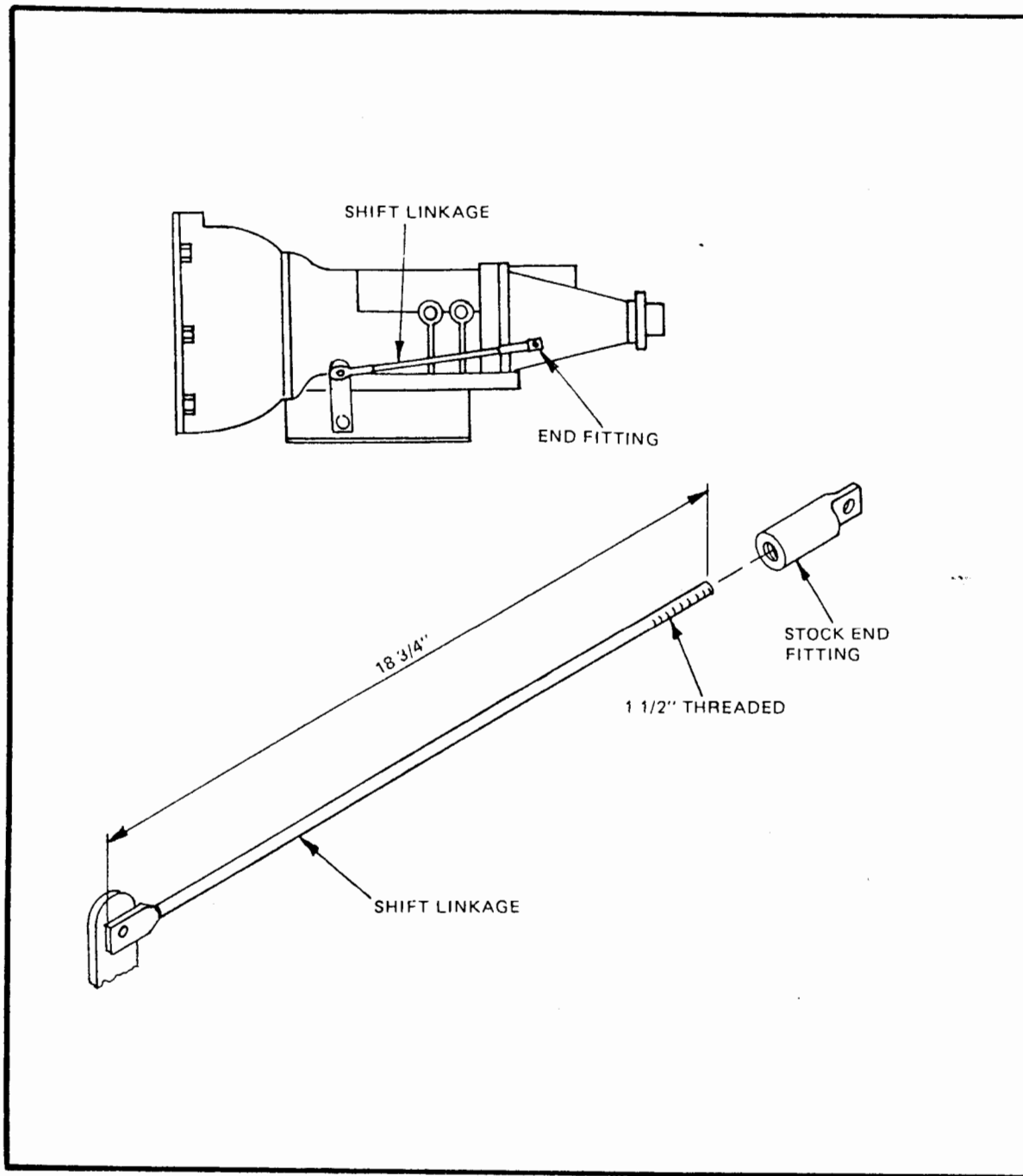

Figure 26

SHIFT LINKAGE

- The standard Chevette shift rod is too short and while it is possible to extend the original rod we suggest you make or have one made as per Figure 26. An alternative one is available as an option from the factory. The new rod is 8mm x 18 3/4" as opposed to the 11 1/4" stock Chevette rod. It is threaded 1 1/2" on one end to accept the stock end fitting, 1.25 pitch.
- Attach original end fitting and adjust rod to proper length. Make certain that rod is adjusted properly and that all gears fully engage or transmission damage may result. Also make certain that neutral safety switch operates properly. When properly adjusted insert new cotter pins to secure.

HEATER (OPTIONAL)

- The heater from the Chevette is not usable on the Replica assembly because of its size. A small auxiliary heater is needed such as the one available from our factory.
- Glue a piece of rubber matting over the hole on the right side of the heater. It is not used and must be sealed. It would be a good idea to put several 3/4" self-tapping screws through the rubber matting to further secure it to the heater.
- Mount the heater to the firewall. Our optional steel firewall has the holes drilled. If you have made your own, refer to Firewall Diagram. Secure with hardware included with the heater. Connect valve and heater hoses to connections on engine.

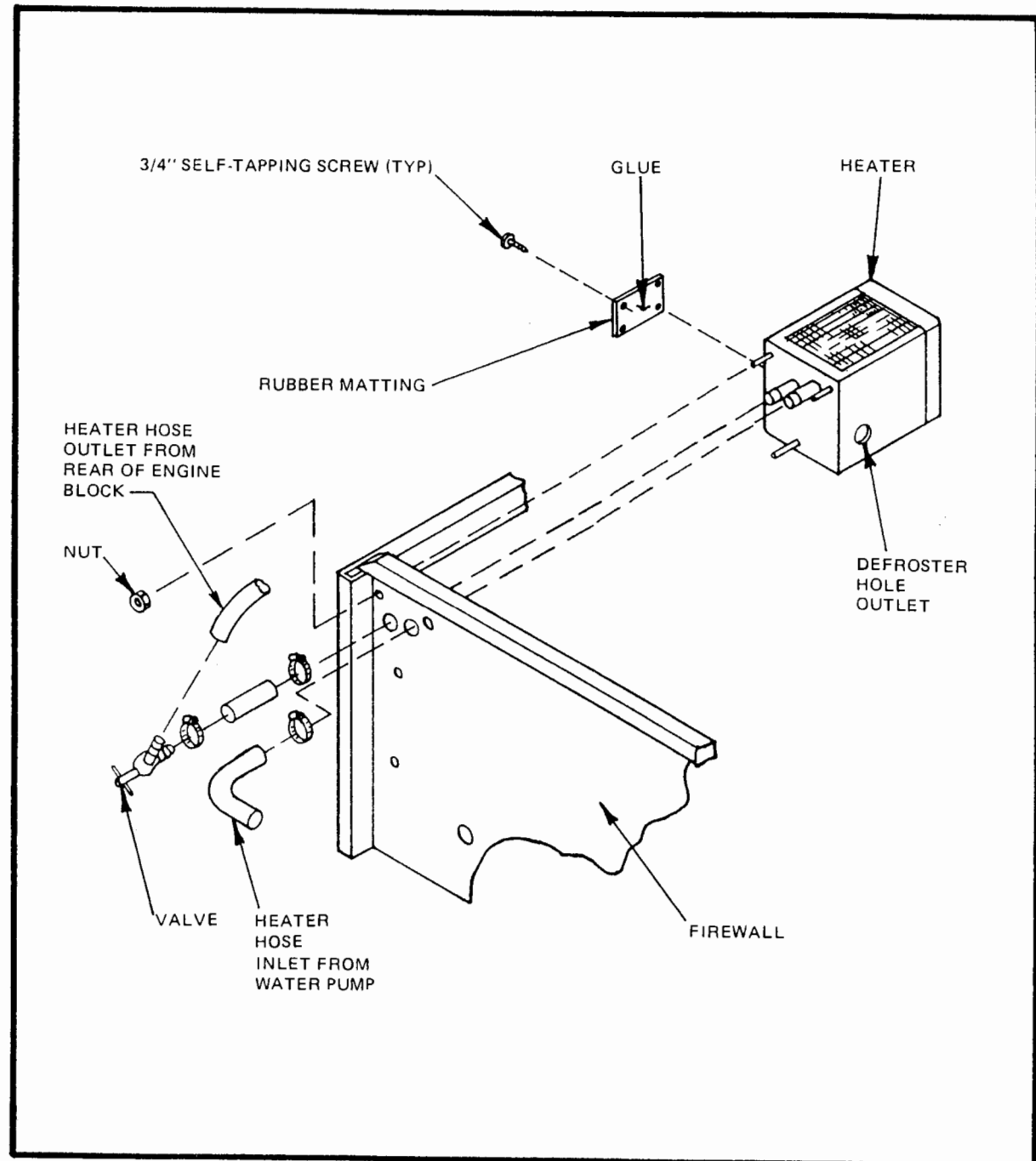

Figure 27

ACCELERATOR

- Unbolt and discard back plate of accelerator pedal with studs attached. Cut off any protrusions on the back of the plastic pedal cradle. Locate pedal assembly against firewall through the upper right (passenger side) hole in the assembly and the upper right accelerator mounting hole in the firewall (see diagram 28). Secure temporarily with a 1/4" bolt and adjust to preference. Mark lower left mounting hole. Remove assembly and drill 5/16" hole. Secure assembly to firewall with two 1/4" x 1 1/4" bolts, lockwashers and nuts.

NOTE: If the angle of the accelerator pedal does not appeal to you, the pedal shaft can be heated and bent on the straight section just above the pedal pad.

ACCELERATOR CABLE

- Place grommet through slot in firewall. (Refer to Figure 28 for slot location). Twist to secure. Attach pedal to cable. Note if cable is too long, simply tie knot between stops as shown.

OTHER ACCESSORIES

- Other accessories, such as windshield washer, emission control absorption box, etc., can be mounted at any convenient spot. Remember that access to the engine is from the left side, since the hood hinges are on the right. If there is insufficient room on frame members, special brackets can easily be bolted or welded to the chassis.

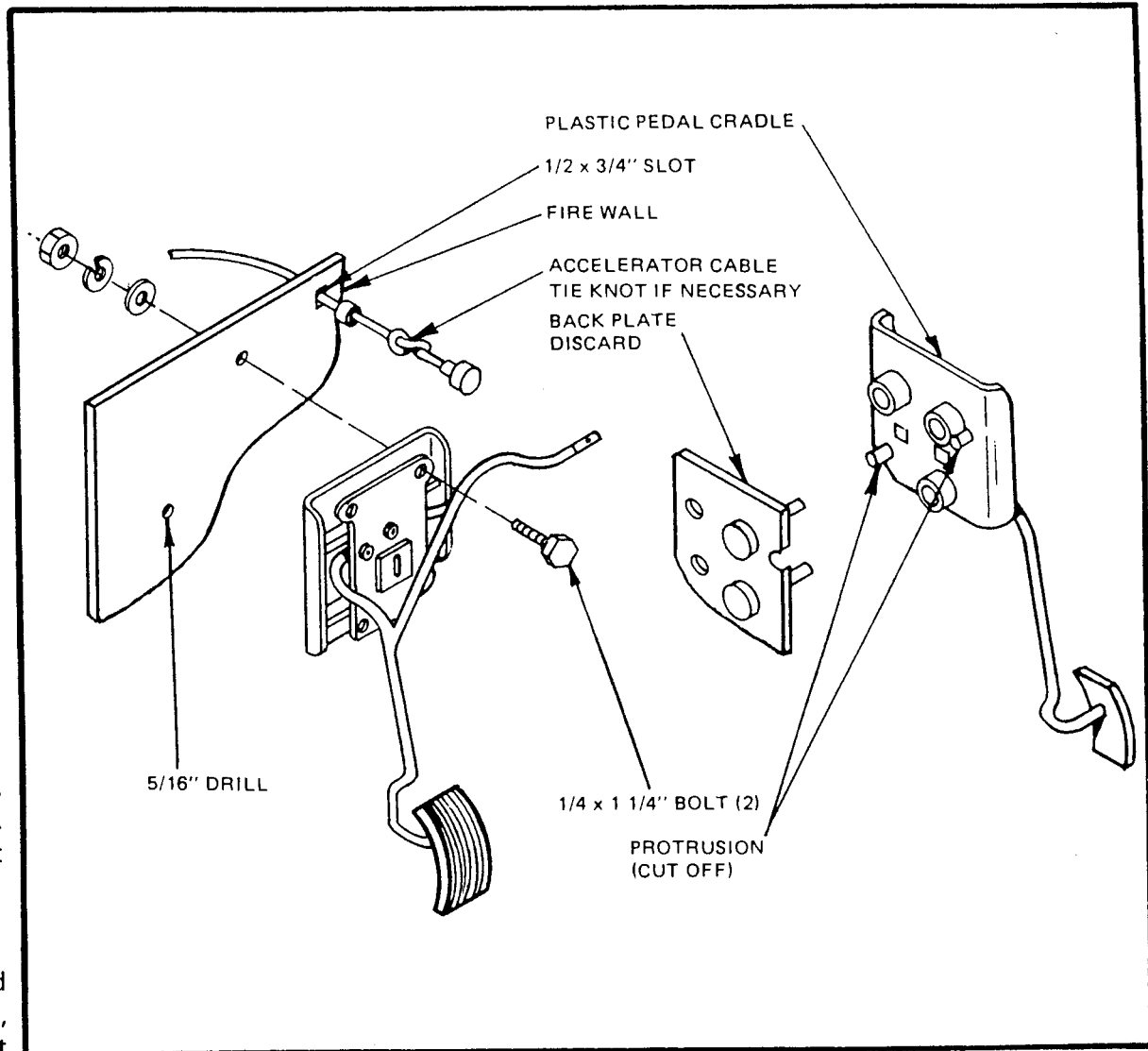

Figure 28

CAUTION. When positioning engine accessories, always check clearance by fitting the fiberglass body over the chassis.

PAINTING

- Paint all frame and suspension parts with primer and a good quality black paint.

FIBERGLASS PREPARATION

The following information will help you in working with fiberglass.

Read this section all the way through before starting work.

- When drilling fiberglass, always use the slowest speed possible, use light pressure to avoid unnecessary heat build-up, and ensure that the bit has started in order to prevent it from "walking".
- When cutting fiberglass, always mark the outline of the cut with a grease pencil (do not use marker pencils since they can stain and discolor the lighter body colors), cut inside the drawn area, and finish off with a file. An ordinary hacksaw (or sabersaw is sufficient, but be sure that only a metal type (fine tooth) blade is used to avoid rough cutting.
- When using a sabersaw to cut fiberglass use duct tape or masking tape along cut edges and under shoe on saw (flat portion) that may come into contact with body. This will give you smoother edges and prevent chips and scratches to gel coat.

- When there is no edge (inside cuts) drill hole through fiberglass large enough to accommodate saw blade.
- Since occasional fitting of the body to the chassis will be required, it is best to set them up side-by-side.

CAUTION: Do not cut out the doors of the body until it has been attached to the chassis. Otherwise, the door channel may crack or break.

- When bolting fiberglass to metal or fiberglass to fiberglass always use a flat washer next to the fiberglass to spread the stress over a larger area.
- Set up all the parts to be glassed in the correct positions, and then cut the matting (fiberglass) material to size and shape.
- Have fiberglass mat or tape on hand and a gallon of resin and hardener (methyl ethyl ketone).
- Mix the resin and the hardener according to the manufacturer's instructions.

WARNING: Be sure to observe manufacturer's safety precautions for handling the resin and the hardener.

- Resin can best be applied with a brush. First, apply resin to the work area, then lay in glass cloth. Thoroughly saturate the cloth with resin using the brush.

NOTE: It is essential that, when applying new fiberglass to fiberglass or metal, the mating surfaces be prepared by sanding with a medium grit sandpaper to roughen the surfaces for a better bond. Carefully sand all smooth gel coat (colored) areas to ensure a good bond.

- Clean the brushes or any other tools which you may have used with any regular cleaning solvent (such as acetone) sold especially for that purpose from the store where you purchased the rest of your fiberglassing materials.
- All finished edges of fiberglass parts, such as fender edges should be given a light sanding. Sand only along the edge. Never sand across the edge from the inside out as this will chip the gel coat.
- For minor repairs to fiberglass or gel coat see Appendix "A".

BODY ASSEMBLY

- The body is assembled before mating to chassis. Occasional trial fitting may be required.
- Support the body on two saw horses to facilitate access.

FRONT FENDERS (Refer to Figure 1)

- NOTE:** If using optional exhaust stacks refer to instructions before mounting front fenders. Holes for exhaust stacks must be cut before front fenders are mounted.
- Align the fenders with the contours of the body, matching the height front

and rear. (Matching front body horns is not critical as they will be trimmed later.) When position is found clamp in place. Drill $5/16''$ holes approximately 5'' apart. Secure with $5/16 \times 1 \frac{1}{4}''$ bolts with 2 flat washers, lock washer and nut. Do not tighten fully. Insert welting between fender and body tightening bolts as you go. (See Figure 1)

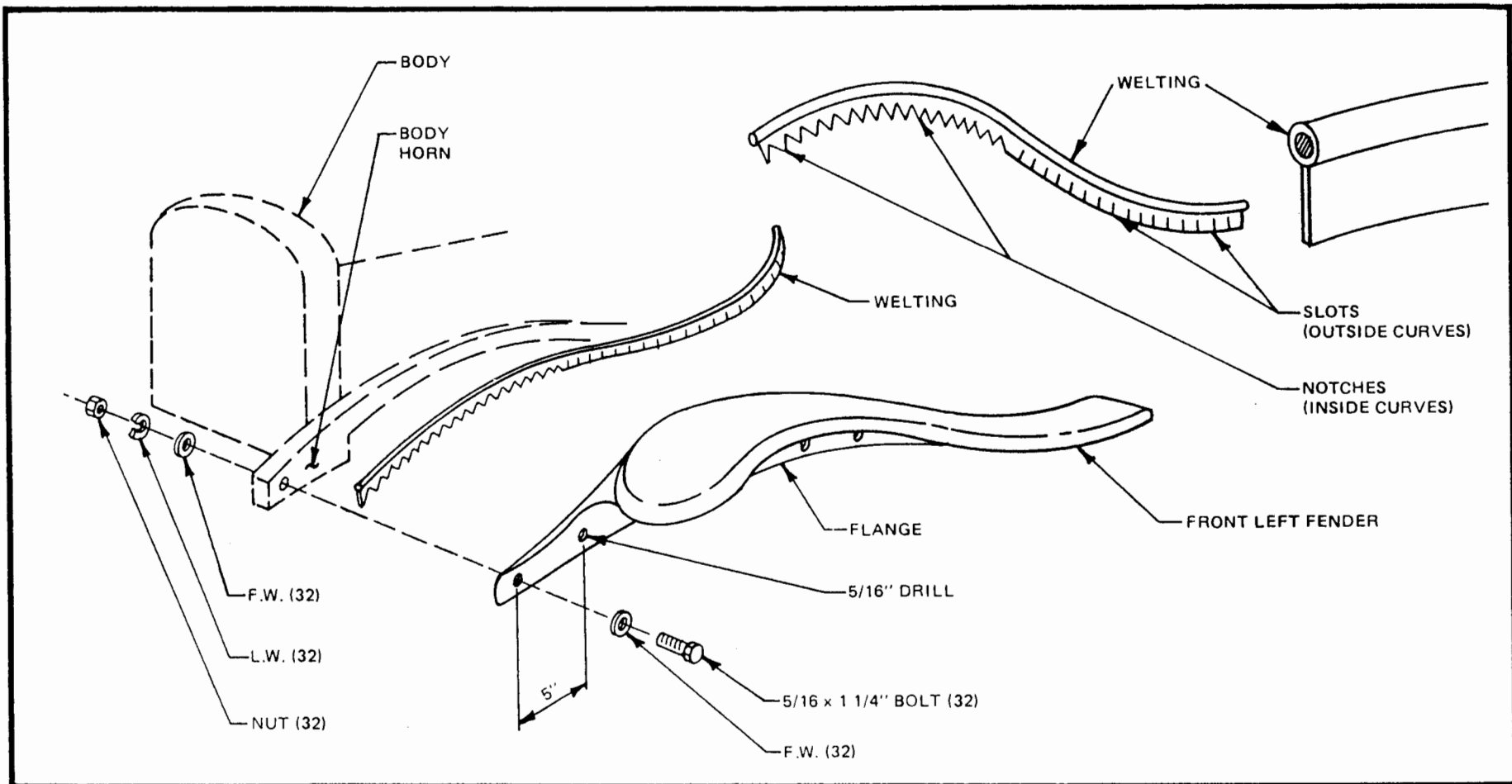
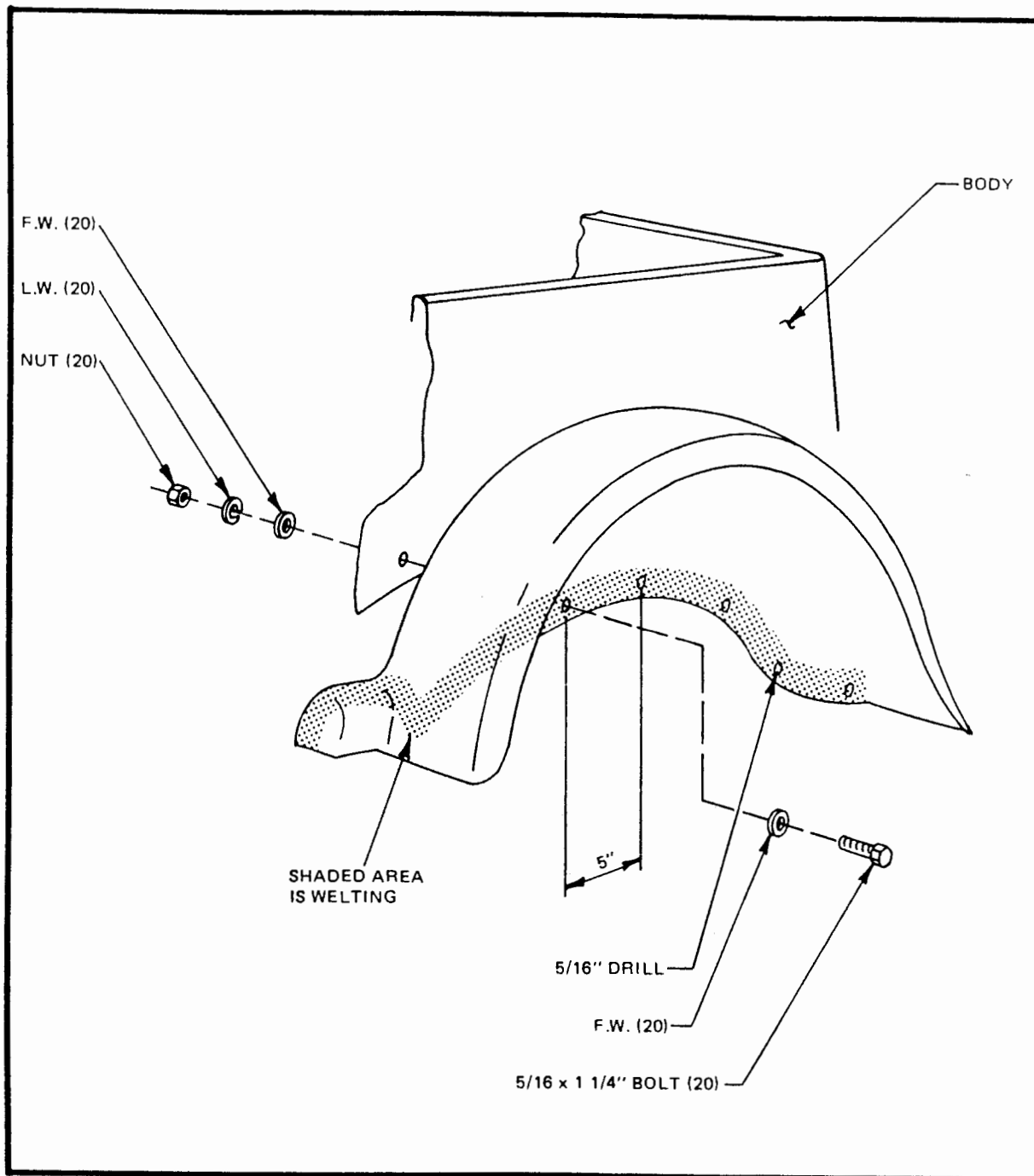

Figure 1



REAR FENDERS

- Align rear fenders with body line and clamp in place. It may be necessary to grind away some of the lower edge of the fender to achieve an even height. Clamp in place and drill 5/16" holes approximately 5" apart. Secure with 5/16 x 1 1/4" bolts with 2 flat washers, lock washer and nut. Do not tighten fully. Insert welting between fender and body, tightening bolts as you go. Refer to Figure 2. Cut welting even with bottom edges of fenders.

Figure 2

BODY CUT OUTS

- Cut out inner lip around engine compartment except for the rear and 12 1/2" on each side. (Figure 3) Use a saber saw with fine tooth blades. At the front of the body (behind grille shell) cut out the entire area leaving 3" on the bottom end, 1" on each side and top. Check the body fit to make certain engine accessories clear body lip.
- Do not cut out the doors at this time as it will weaken the body.
- Other cuts will be made later to clear the rear bumper brackets and will be dealt with in that section.
- The stock Chevette hood support rod is ideal for use on the assembly. Shorten rod to 23". Mount on back flange of body as shown in Figure 3.

EXHAUST STACKS (OPTIONAL)

- Mark the hole centers on the body (Figure 4) and drill holes. Use 1/4" drill bit.
- Drill three 1 7/8" holes in each fender (Figure 4). Draw diagonal line through hole centers on body and fenders where trim pads are placed.
- The length of the exhaust stacks are 30", 27 1/2" and 24" when fully extended. The largest goes in the front hole, the smallest in the rear. Check length of stacks through holes in fenders and cut if necessary to proper length.

- Grind the edges of the exhaust stacks smooth at approximately a 10° degree angle.
- Obtain 12 flat washers to fit the inside diameter of the exhaust pipe.
- Drill a 1/4" hole in the center of the flat washers and spot weld a 14-20 bolt to the washer so that the bolt extends through the hole in each washer. Note, when welding, cover threaded portion of bolt with masking tape. Spot weld the washer into the end of the exhaust pipe. Note, an alternative method of attaching the exhaust stacks is to obtain twelve 1 5/8" rubber core hole plugs (freeze plugs) from a local auto

supply store. Napa Part No. 600-4008 or equivalent. Place plugs through holes in body. Washers on the inside of body. Apply pressure and attach nuts. Slide pipe ends over plugs and tighten until secure. (Do not overtighten.)

- Fit trim pads on the exhaust stacks and slide through holes in the fenders. Line up hole centers in trim pads with diagonal lines on fenders and body sides. Mark hole locations and drill (3/16" drill) mounting holes. Secure pipes to body with 1/4" flat washers, lock washers and nuts. Attach trim pads with 24 No. 10 x 1" stainless steel oval head machine screws, with flat washers, lock washers and nuts.

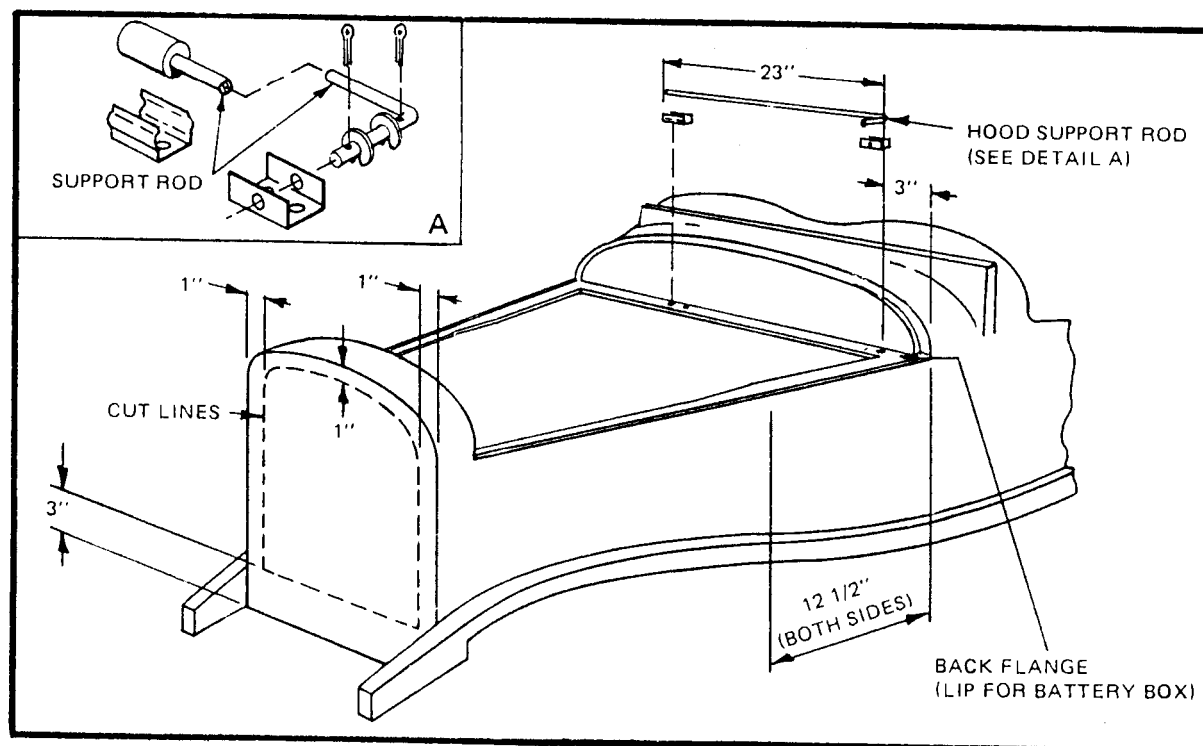

Figure 3

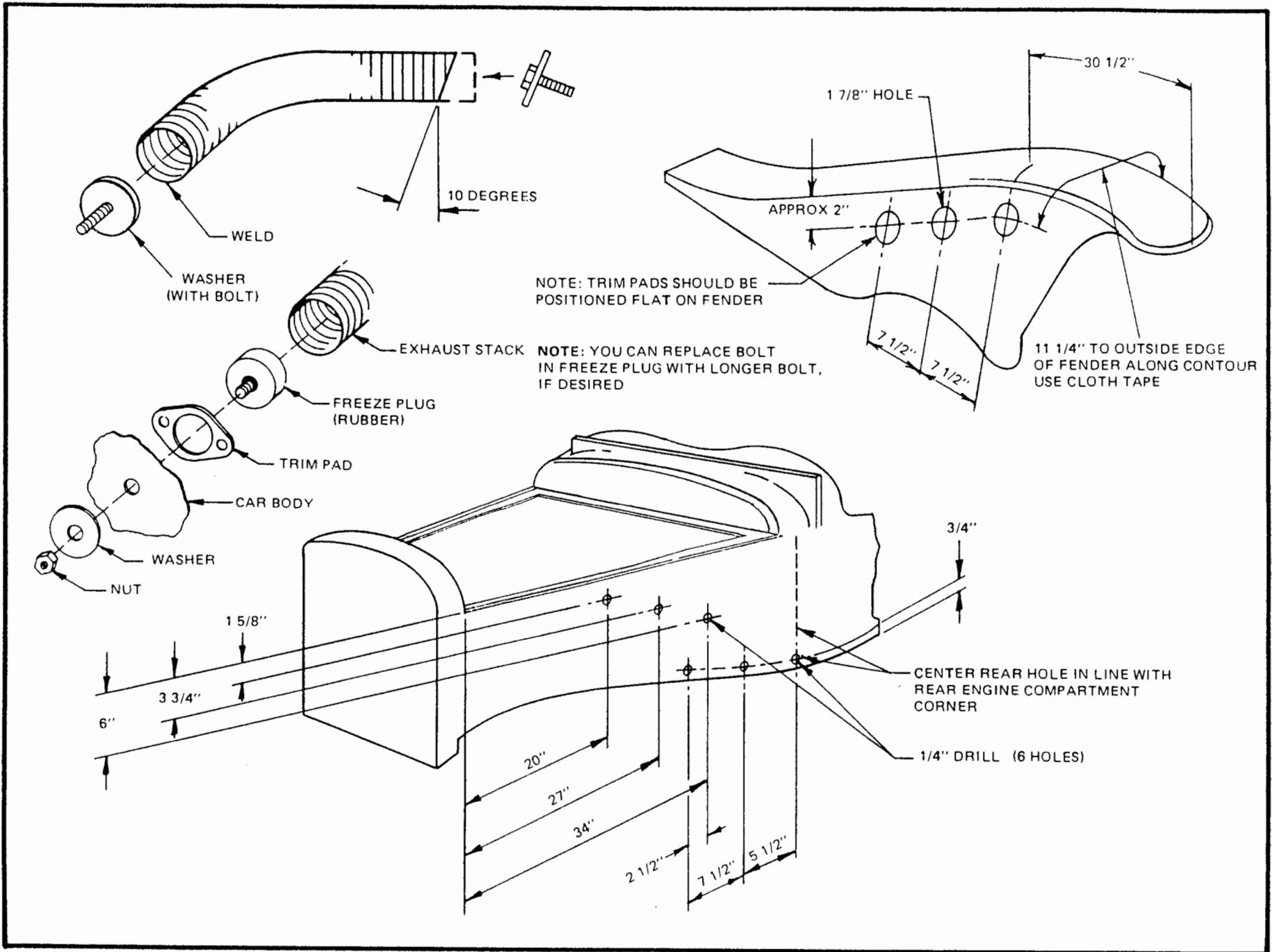

Figure 4

TAILLIGHTS

- Measure up 7" from the end of the rear fender and mark bottom of taillight.
- Using the rubber gasket as a guide locate the holes for the taillights on the rear fender. Drill for two 3/16" mounting holes. Drill 3/4" hole through fender for bulb socket. Attach socket with two No. 10 x 3/4" round head machine screws with flat washer, lock washer and nut. Attach leads to lights at this time to facilitate hook up later. Secure chrome bezel with No. 10 x 1 1/4" machine screws, flat washers and nuts.
- Route leads to the body and attach with a small ring clip or similar fastener. Make sure leads are taped and can't contact rear tire. You can fiberglass wires to inside of rear fender for protection.

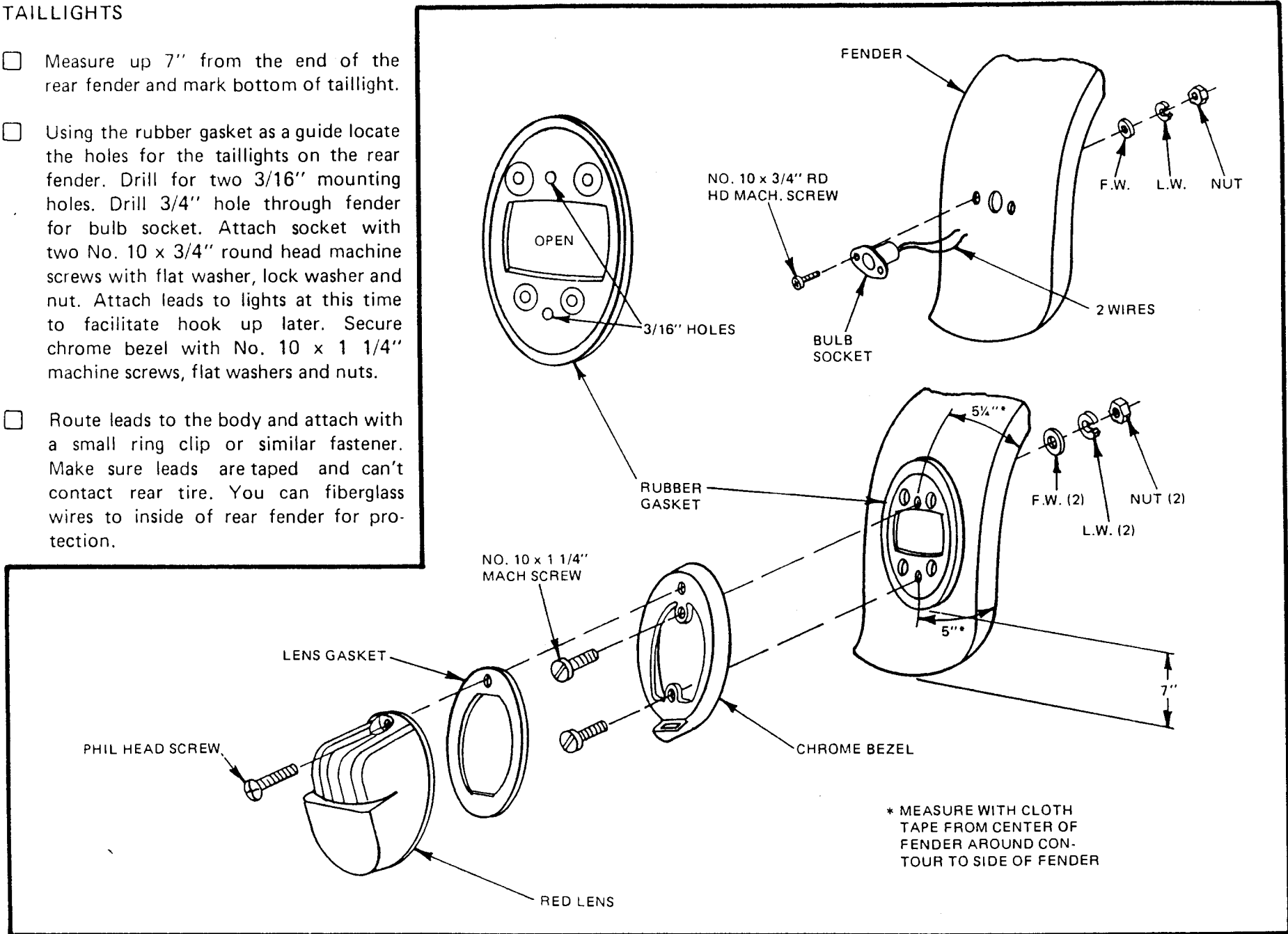

Figure 5

PARKING LIGHTS

- Using the rubber gasket as a guide, locate the holes for the parking light on the top of the front fender. Move the gasket back and forth until the extreme top of the fender is found. (Figure 6) Drill as indicated for two mounting screws and wires, (1/4"). Attach leads to lights at this time to facilitate hook up later. Secure with 1/4 x 3/4" and 1/4 x 1" bolts, SAE fine thread (short bolt in front of light, long in rear).

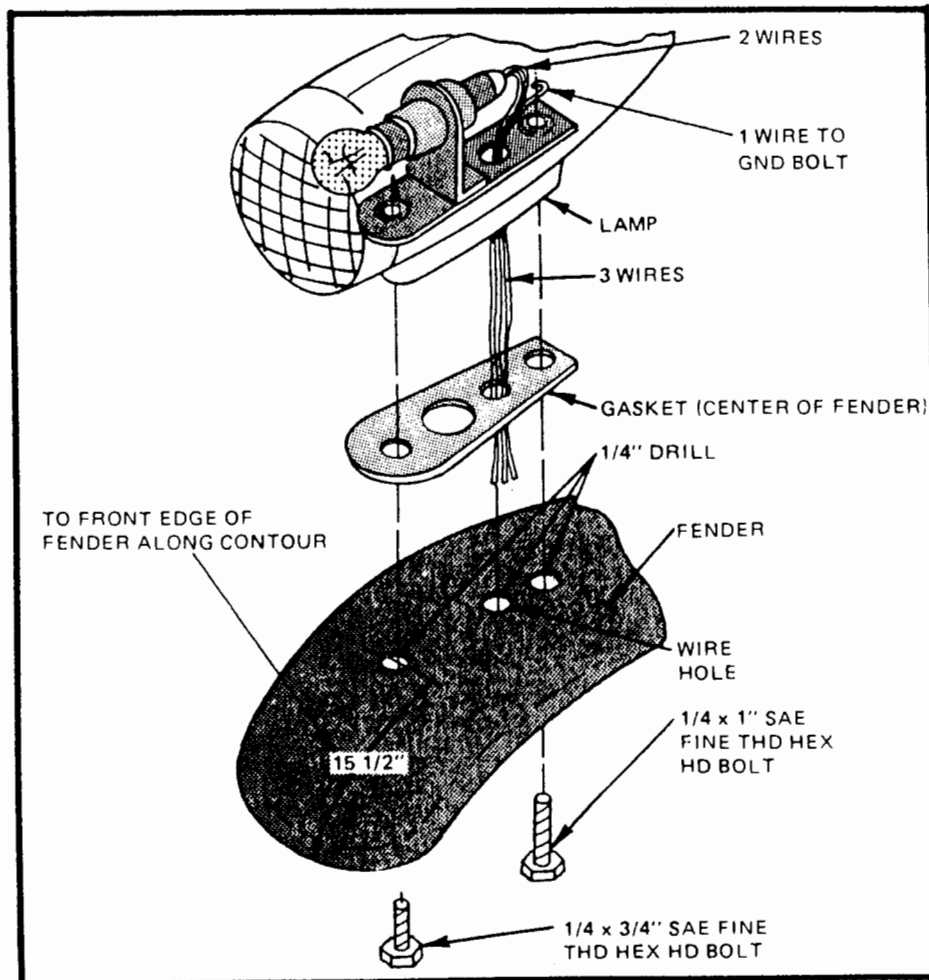

Figure 6

DASHBOARD ASSEMBLY AND WIRING

NOTE: Dashboards are furnished uncut to let you use a variety of gauges.

NOTE: If using our gauges, a suggested layout is shown in Figure 7. Many other arrangements are possible.

NOTE: If using Chevy or other gauges check the mounting method and dimensions before starting. You may need to

fabricate adaptors to route out or counterbore the dash to make them fit.

- After establishing the layout, mark the opening and make cuts. Finish dash as desired.

NOTE: Do not cut the steering slot until you fit the body to the chassis to get the exact location.

- Install the gauges and secure them in place. Note, if using our prefinished dash exercise caution when tightening gauge brackets. Too much pressure can cause finish to crack. Wire gauges now. (See wiring diagram)

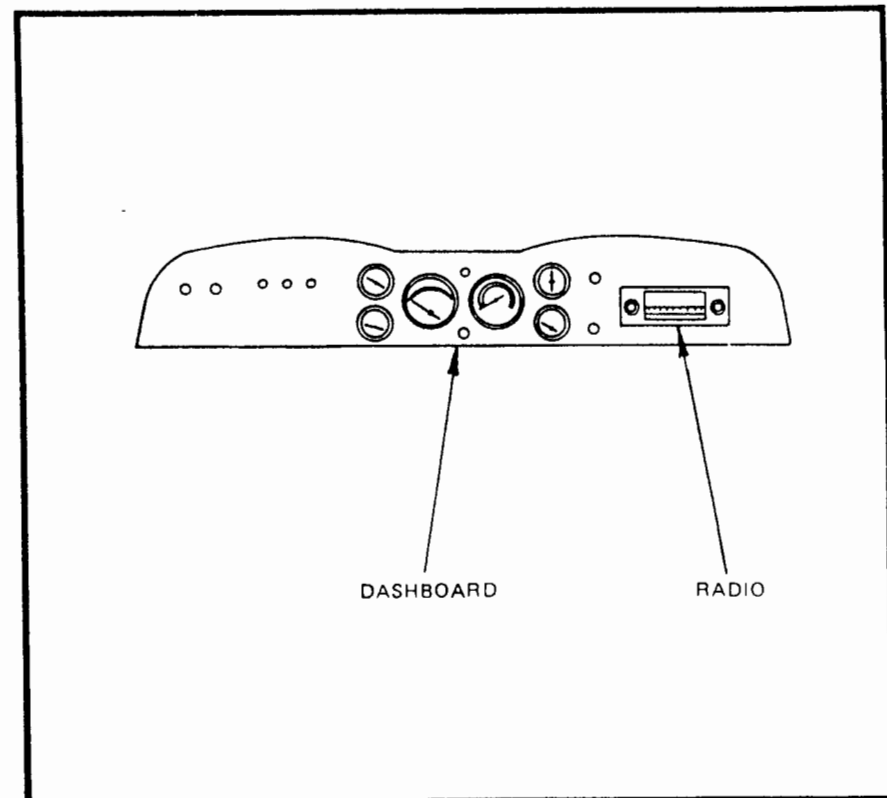

Figure 7

DASHBOARD ATTACHMENT AND SLOT FOR STEERING COLUMN

- Turn body upside down and position the bottom edge of the dash along the fiberglass lip on the body. If necessary, trim side edges of dash to fit. Drill holes (1/8" drill) through fiberglass and into dash at upper portion of door recess as shown in view A. Secure dash to body with four 1 1/2" No. 8 stainless steel flat head screws. Counter sink so screws are flush with gel coat finish.

- Unbolt steering column. Place body over chassis. Place top of steering column against bottom edge of dash. Note, you can suspend column from bracket with long bolts to line column up properly. Make a circular template the diameter of the steering column below the dash. Measure distance between steering support brackets on frame and mount on column. Transfer this measurement to template and cut to size. (See view B) Trace this area on dash.

- Remove dash from car. Mask off area so flat of saw will not scratch dash. Remove any gauges, lights and switches that are in the way. Cut out area carefully with saber saw (fine blade). Attach dash and check fit. For a finished appearance cut a piece of welting to fit between dash and steering column.

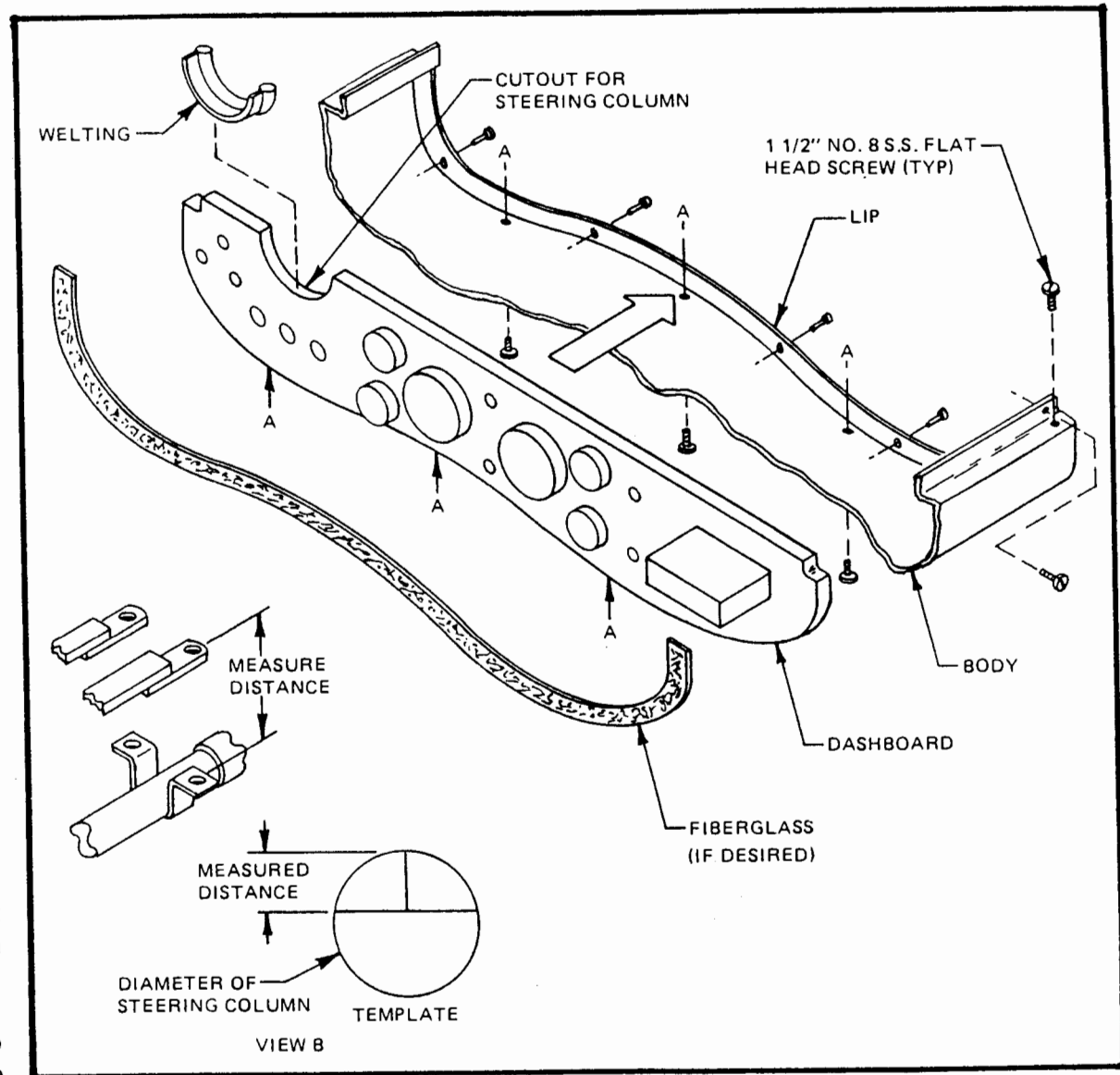

Figure 8

- Remove body and reattach dash. You may fiberglass back of dash to inside of body or if you prefer, carefully drill six 1/8" holes down through the top lip of

the body into the dash and secure with 1 1/2" No. 8 stainless steel screws. This area will be covered by the dash padded roll and will not show.

DEFROSTER DUCT INSTALLATION (OPTIONAL)

- Cut slots for defroster ducts just behind the raised ridge, which supports the windshield. (Figure 9) Note, you can use an electric drill with rotary file or rasp.
- Angle both ducts toward the right (passenger) side of car. This will facilitate connections to the heater.
- Insert ducts and glass in place.
- Glue a piece of windshield washer hose around duct to finish it off.

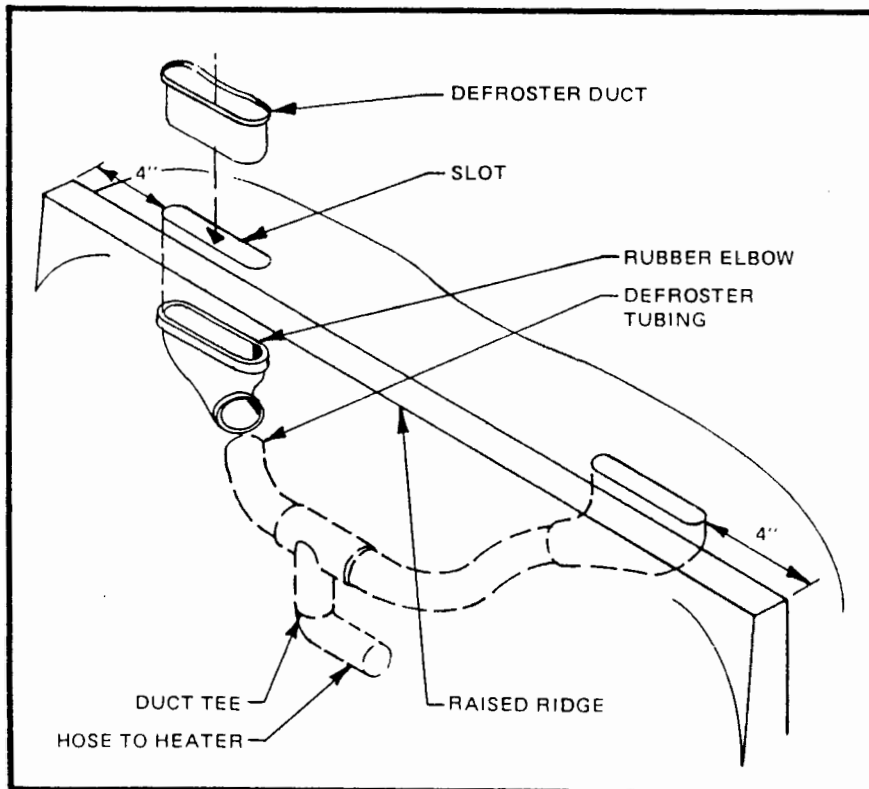

Figure 9

INSTALLING WINDSHIELD WIPER MOTOR

- Obtain windshield wiper motor from a Volkswagen Beetle or order a new one from an auto supply house. Be sure to specify a 12-volt motor.
- Drill two 3/8" holes in the recesses on the body to match the distance between spindles of the wiper (15 3/4" or 16").
- Secure with original spindle nuts and washers.
- Attach Trico arms, part no. AL-225 and blades TAU-8 1/4", or equivalent.

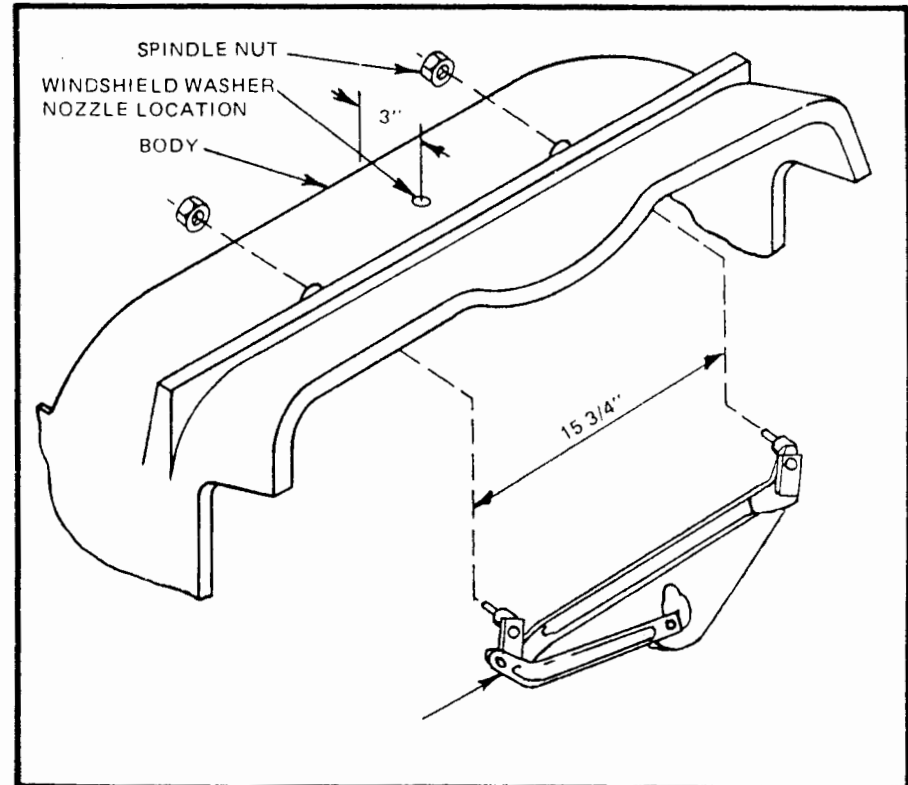

Figure 10

WINDSHIELD WASHER (OPTIONAL)

- A variety of windshield washers can be used. We use a small unit with a flexible reservoir. Because of windshield size we utilize a standard V.W. Beetle nozzle that is mounted through a 3/8" hole in the center of the cowl, 3" from the front lip. Note: DO NOT USE wiper posts to center nozzle as they are offset. You will mount the reservoir later, on the passenger side of the battery box.

MOUNTING THE HOOD

Fit hood to main body.

- Sand edges of hood until a good fit is obtained.
- Use washers as spacers on the right side to align the hood with the level of the body.
- Align hinges on right side of body and drill $3/16''$ holes for mounting. Secure with No. 8 x 1'' stainless steel oval head machine screws with flat washer, lock washer and nut. Note: Grind lip slightly to clear nut if necessary.
- Align latches on left side of body and drill $3/16''$ holes for mounting. Secure with No. 10 x 1'' stainless steel oval head machine screws with flat washer, lock washer and nut.
- Install $1/4 \times 3/4''$ sponge rubber weather stripping to hood where it contacts the body.

PAINTING

For a finished appearance, you should paint the underside of the fenders, the inside of the engine compartment, the underside of the hood and any exposed edges with black paint. Either flat or gloss is fine.

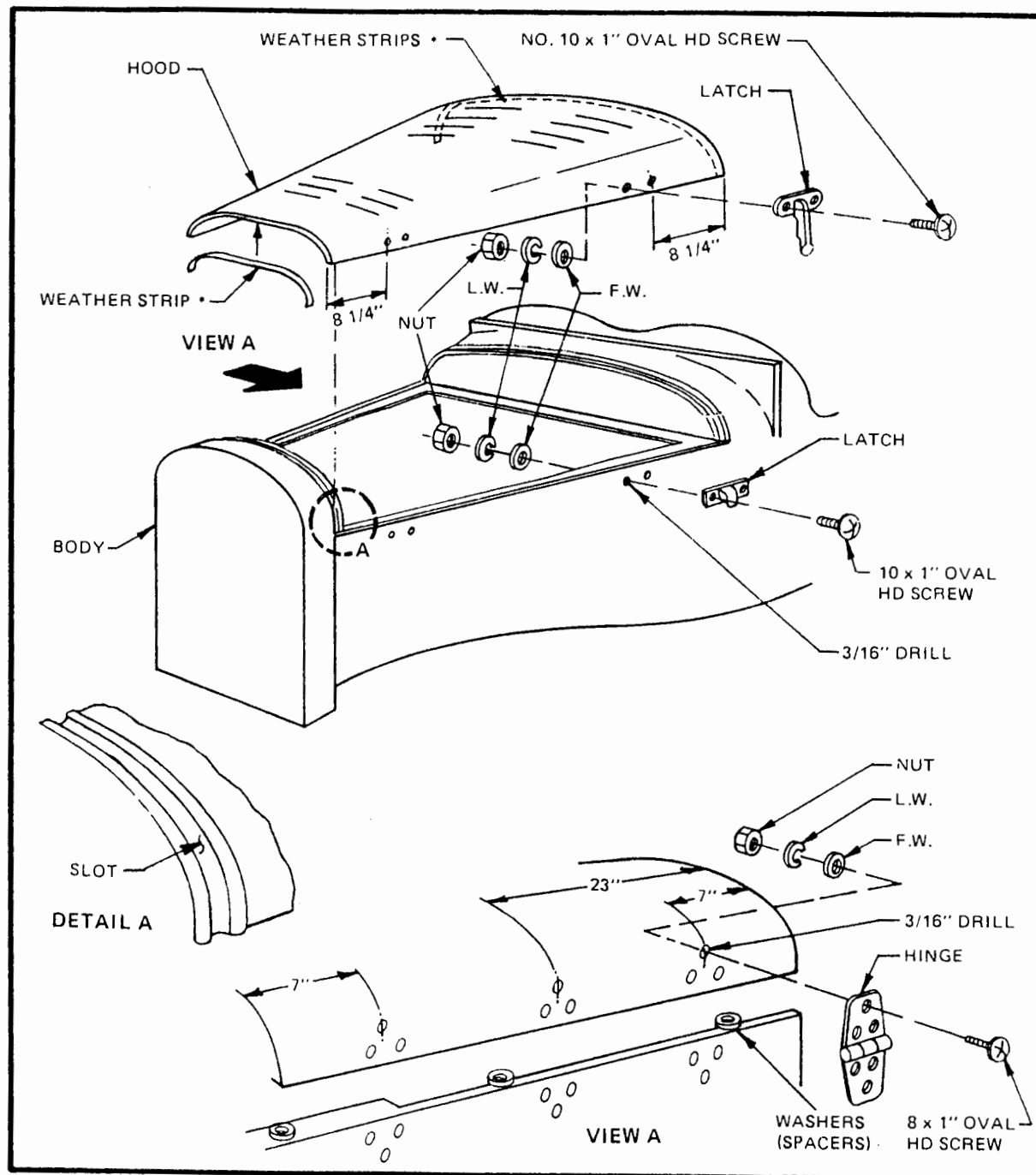

Figure 11

RADIATOR SHELL MOUNTING

- Do a trial fit by placing the radiator shell over the front end and checking to see if it slides down flush with the top of the body. If not, sand to fit.
- Cement welting to the shell so that bead will be between the edge of the radiator shell and the body.
- Slip radiator shell down over the body as far as it will go.
- Using wooden blocks or other soft material to protect the shell from scratching, clamp the top of the radiator shell to the body, ensuring that the top is flush with the body.
- Drill $5/16''$ holes through stamped holes in the shell and install $5/16 \times 2''$ chrome carriage bolts with flat washer, lock washer and nut.

HOOD ORNAMENT

- If mounting a hood ornament drill a $1/4''$ hole through radiator shell. Use a centerpunch to mark location in center of grill $3 \frac{1}{2}''$ back from the front lip. Mount ornament at end of assembly so it doesn't get damaged.

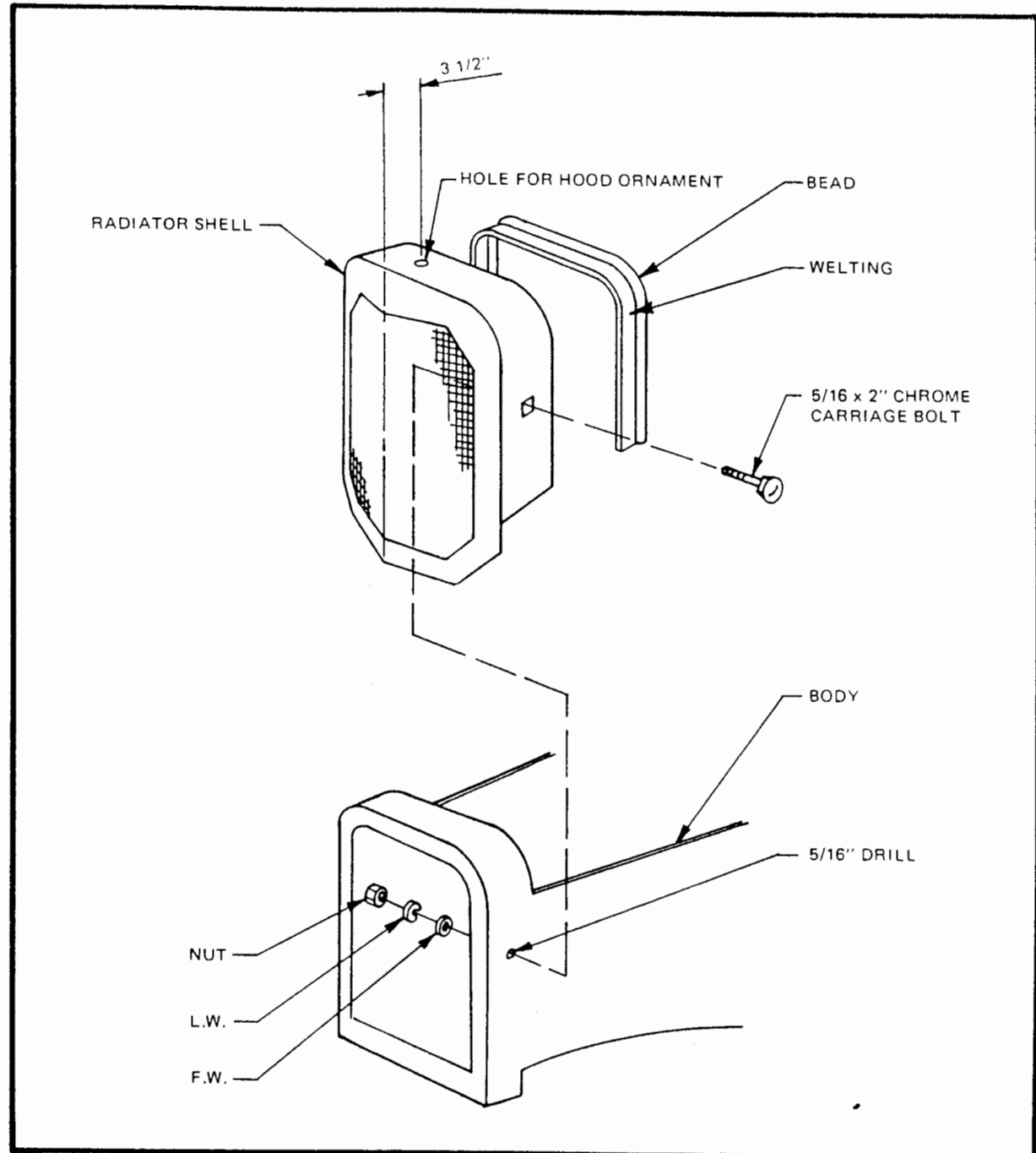

Figure 12

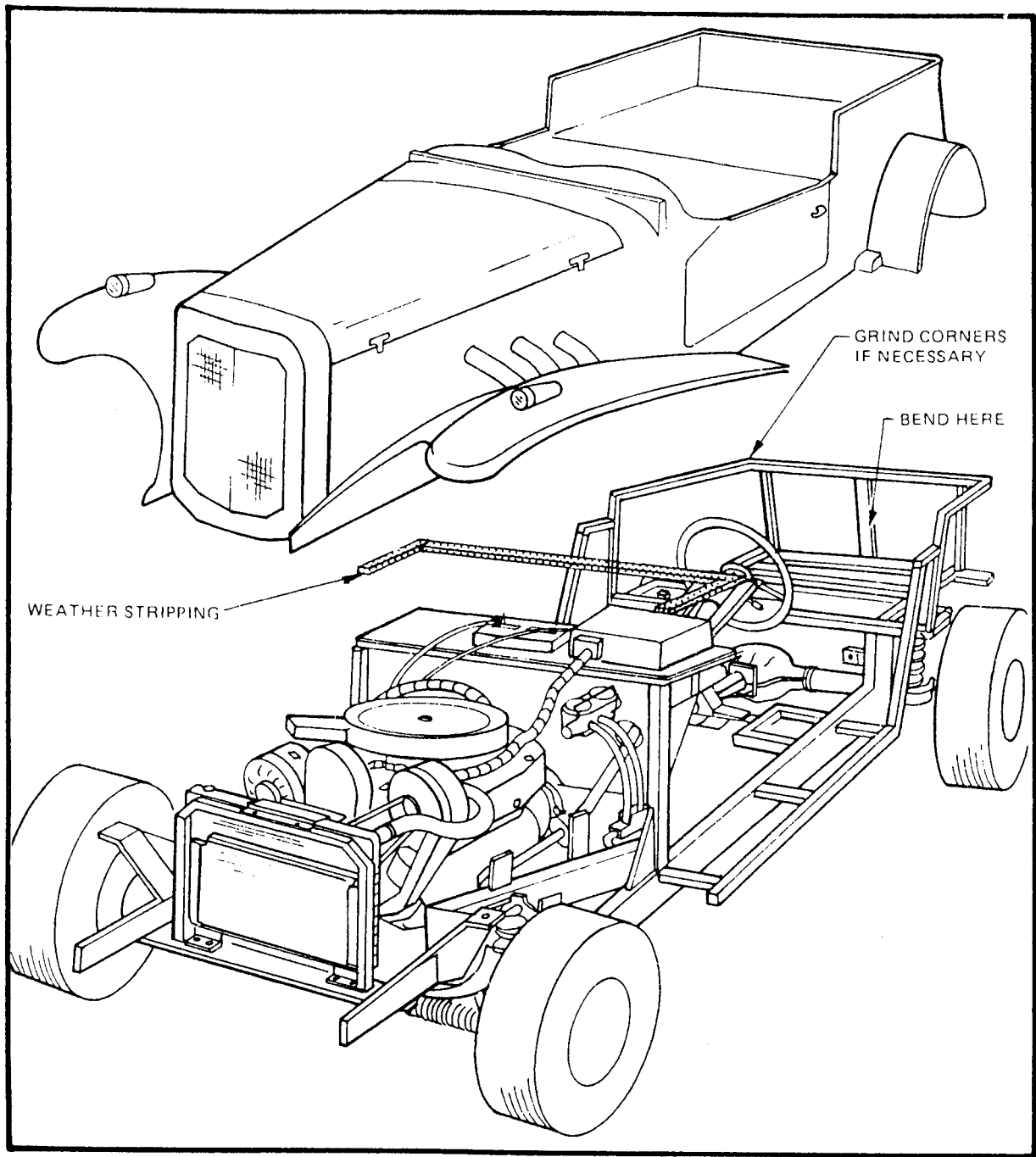

Figure 1

MATING BODY TO CHASSIS

- Once the body is mated to the chassis and glassed in place it effectively forms a one piece assembly.
- Drop the body over the chassis and check the fit.
- The main contact points for the body are the rear corners, the battery box flange and the front horns.
- Some custom fitting may be required to allow for any mismatching. If the body appears too short, grind the rear corners and bend the rear strap to bring it forward.
- Cut away area under front fenders, as required, to clear upper "A" frames. Make sure all engine components and hoses clear. Move as necessary. Once fitted, raise body and block in place.

FRONT BUMPERS

- Standard Bumper - Slide bumper brackets into front supports. Mark hole locations and drill 1/2" holes through brackets. Bolt using 1/2 x 1 1/4" bolts with flat locknuts.
- Optional Bumpers - Slide the bumper bracket extensions and the fog light extension into the front supports. Align all three parts and bolt using 1/2 x 1 1/4" bolts with flat locknuts.

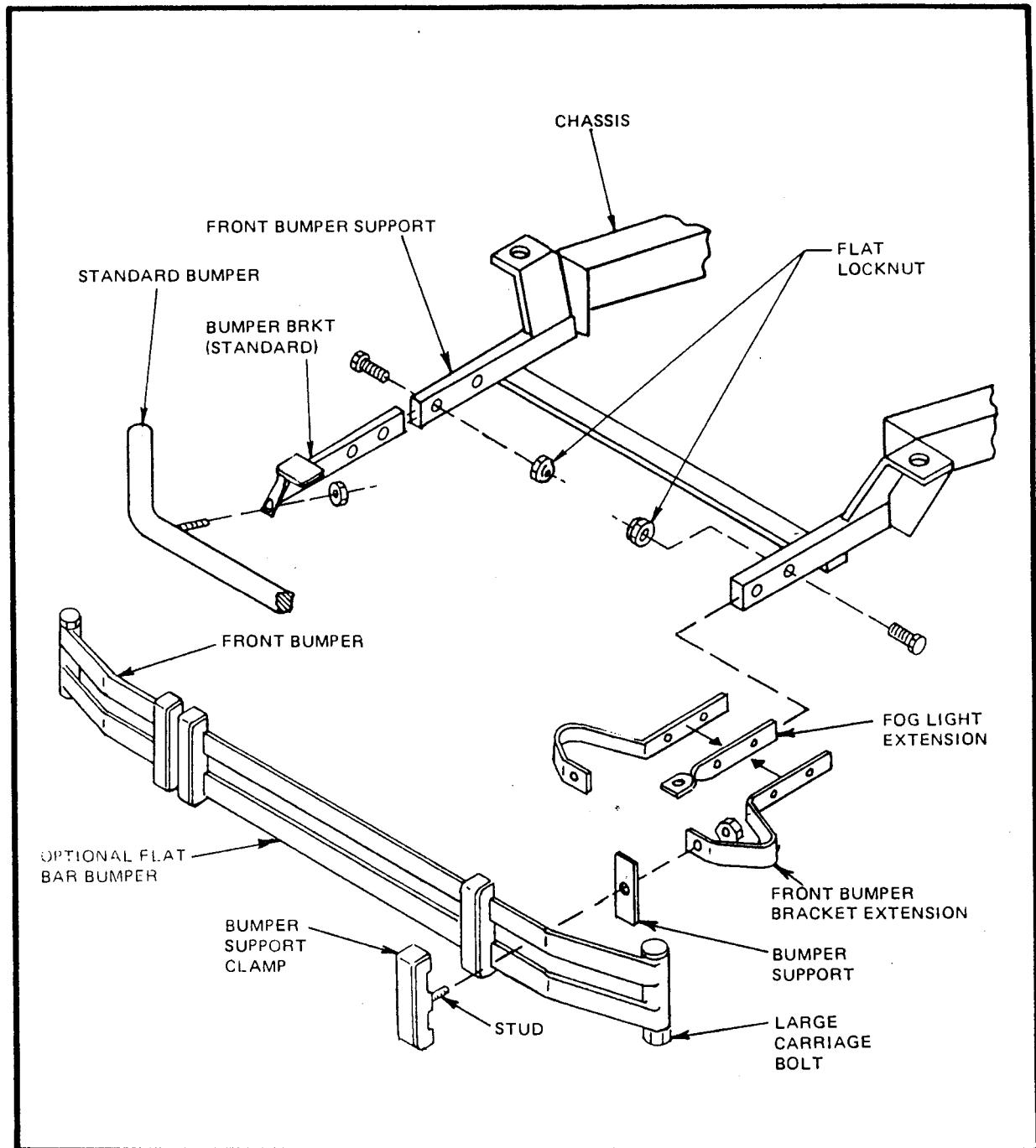

Figure 2

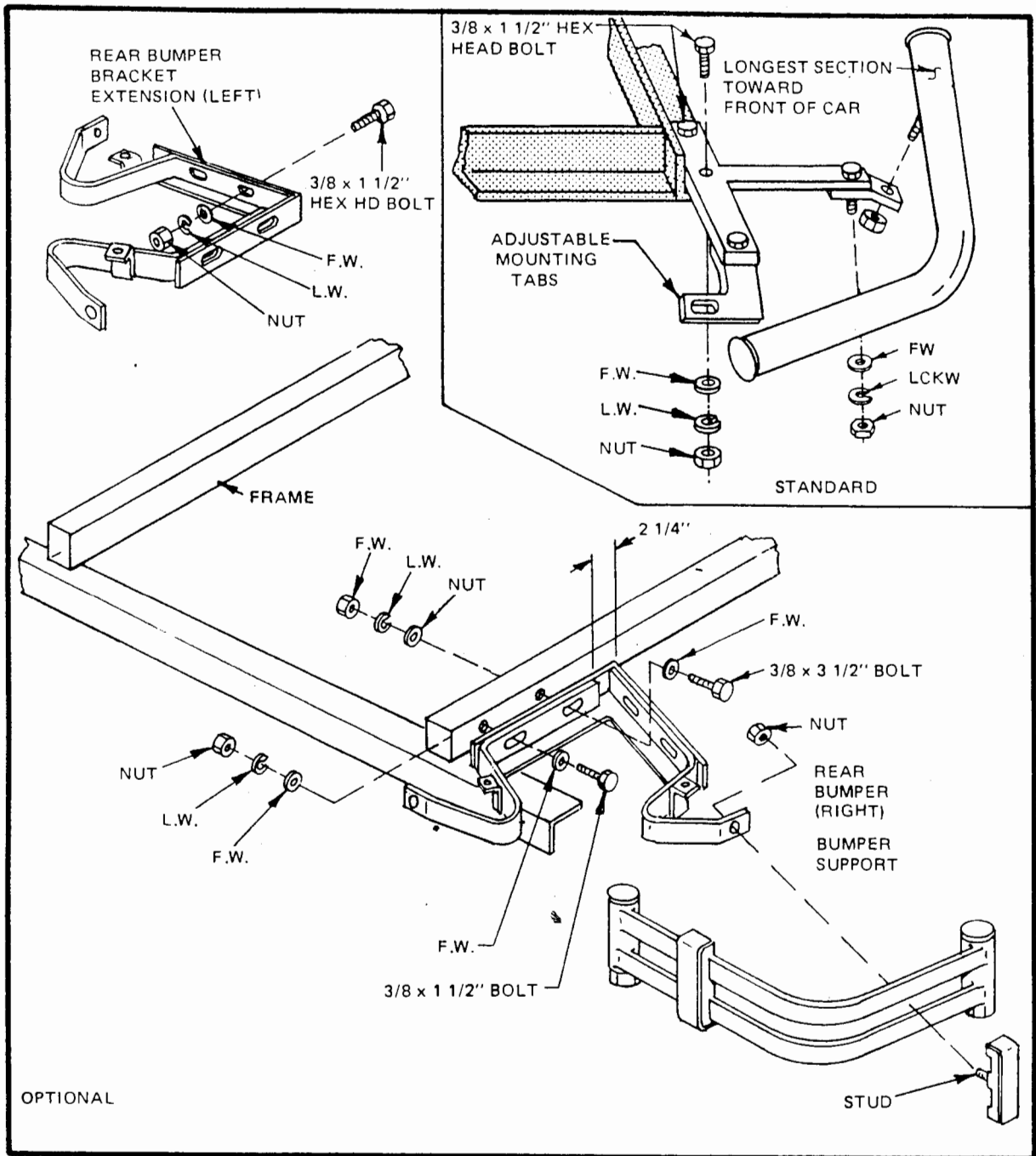

Figure 3

REAR BUMPER BRACKETS

(Refer to Figure 3)

- Attach bumpers to brackets by inserting the studs on the bumpers into the tabs of the bracket. Bolt tabs to brackets using 3/8 x 1 1/2" bolts with flat washer, lock washer and nut.

- NOTE:** To correctly identify the bumpers and brackets proceed as follows:

- The bumpers are designed with the long side projecting forward toward the rear fenders. The studs should be on the lower half of the bumper.

- The bumper bracket is placed with the longer leg to the rear.

- Position the bumper bracket covers on the brackets. Position the brackets on the frame and find the location that allows the cover to mate with the body. Clamp in place. Remove body and drill through bracket and chassis (3/8" drill). Bolt to rear cross member and just forward of rear cross member to avoid obstructing gas tank with 3/8 x 1 1/2" bolts, flat washers, lock washers and nut. Remove bumpers and covers so they wont be damaged. (They will be re-installed later.)

- The rear edge of the bumper bracket support angle lines up flush with the back of the rear cross member. Line up the bumper bracket extension pieces that bolt to bumper on the fender sides against the inside edge of the angle as

REAR BUMPER BRACKETS (Con't)

close to the weld as possible. Drill $3/8''$ holes through angle supports and bolt extensions in place with $3/8 \times 1\ 1/2''$ bolts, flat washers, lock washers and nuts. Bumper extension supports to rear of frame line up against the angle with the rear edge of the extensions $2\ 1/4''$ from the weld at angle of support. Clamp in place and drill $3/8''$ holes through angle and frame rails at front of extension. Secure with $3/8 \times 3\ 1/2''$ bolt, flat washers, lock washers and nuts. Drill through angle and outside of frame rail at rear hole in extension and secure with $3/8 \times 1\ 1/2''$ bolts, flat washers, lock washers and nuts.

- Place body down on chassis so the bottom edge of the body rests on bumper extensions. Mark body where it contacts extensions. To get a good idea of what needs to be cut, measure the distance from the trunk lip of body and the top of the body support rail on frame above the extensions. Transfer this measurement to the body. Carefully trim body to clear extensions.

GAS TANK

- Peel off tank mounting strips and reposition them so they line up with the frame members. Bend down the strap mounting tabs so they point straight down. Attach mounting straps with original torx fasteners. Place tank on floor jack and bring up into position in frame. Bring straps up under tank and pull tightly. Mark hole locations. Drill $3/8''$ holes and secure with $3/8 \times 2\ 1/2''$ bolts, washers, lock washers and nuts. Connect gas feed and vapor lines.

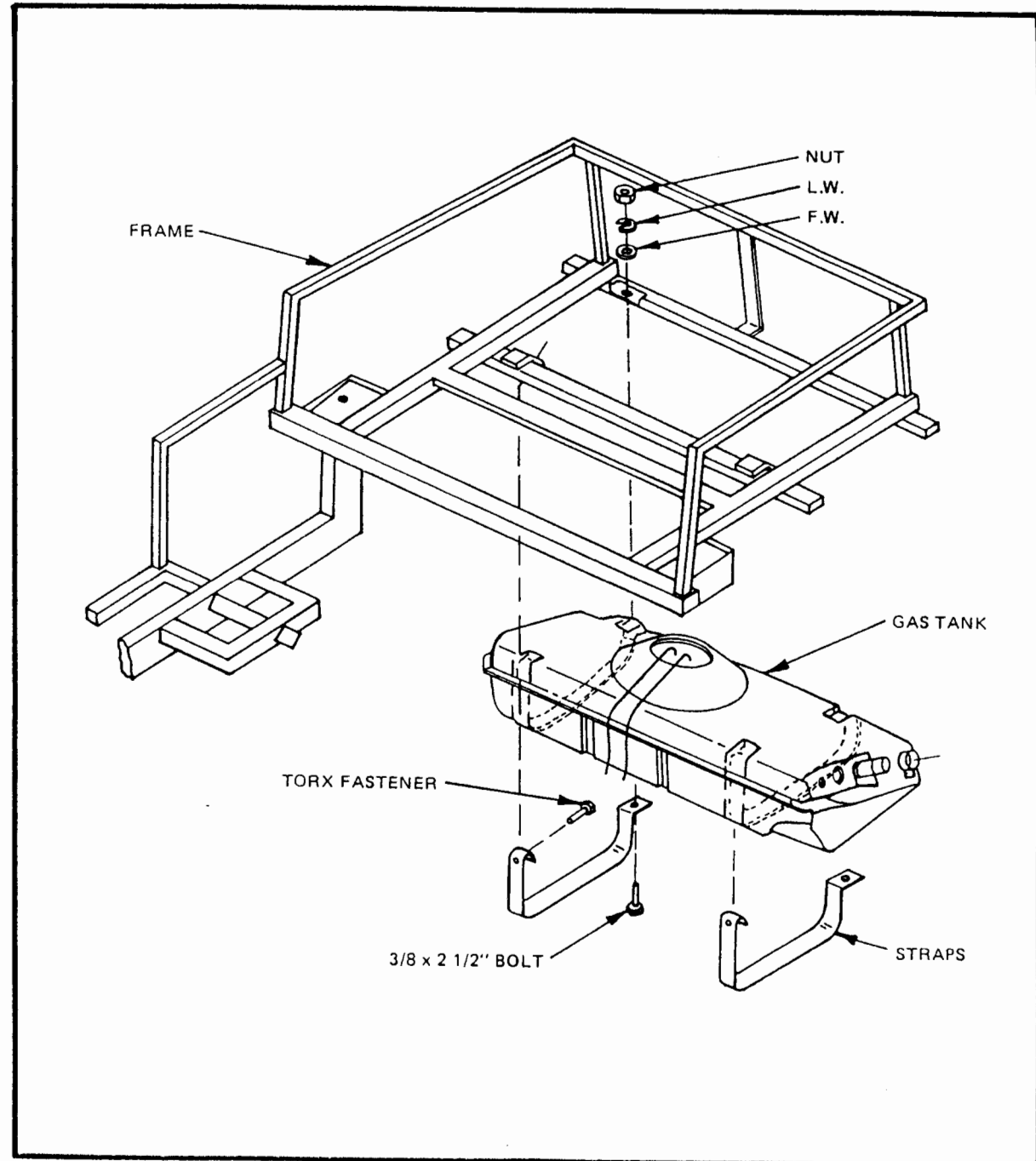

Figure 4

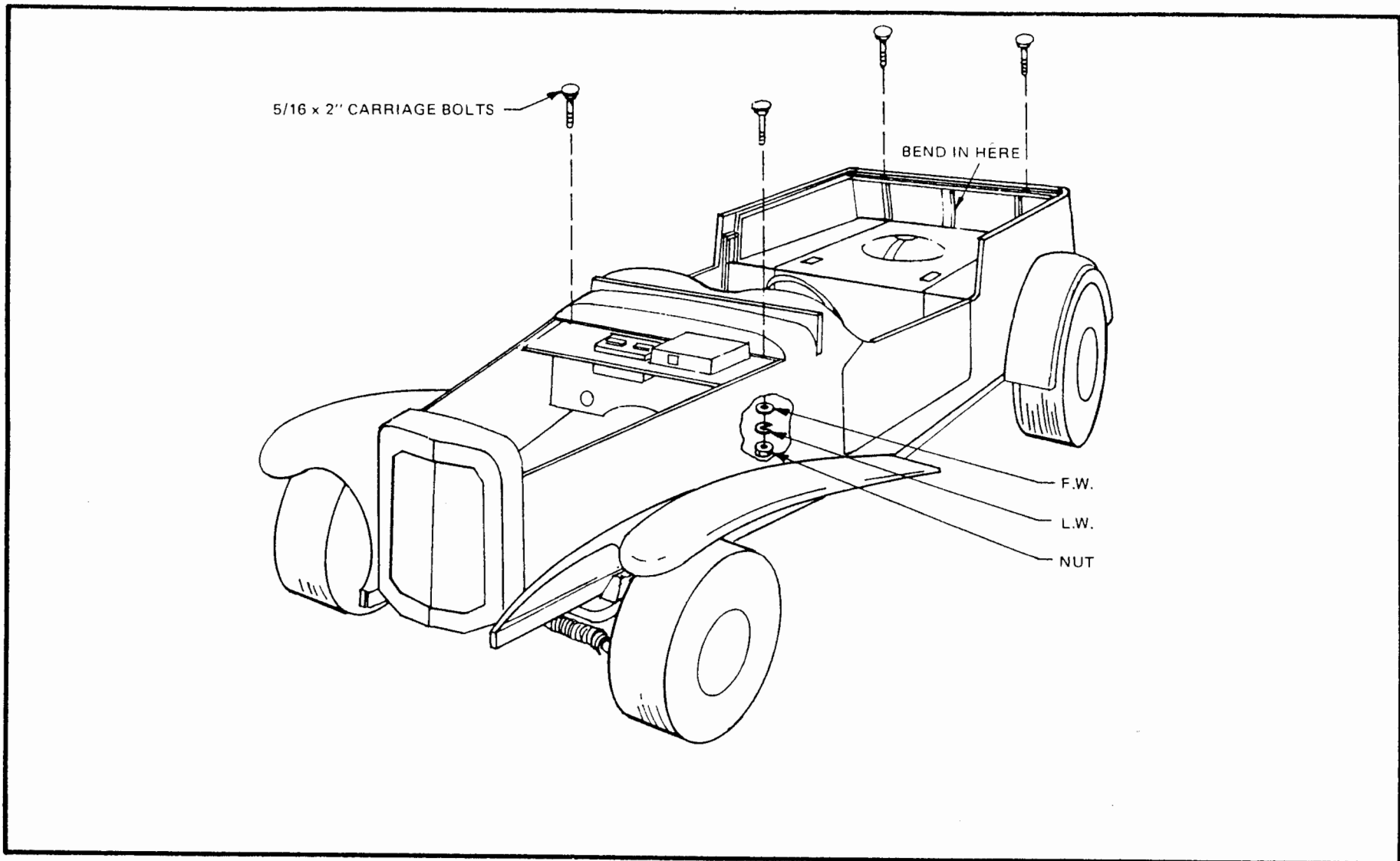

Figure 5

BODY ATTACHMENT

- Recheck fit of the body to chassis. You should be sure that everything is in alignment and that the points previously described are in contact. Attach rubber matting or foam weather stripping to all contact points.
- Using a 5/16" drill bit, drill through body, optional battery box and frame at corners of battery box and secure with 5/16 x 2" carriage bolts with flat washer, lock washer and nuts.
- If necessary, insert wood or plastic spacers between rear frame members and lip of fiberglass. Drill 2 holes, 5/16", and secure with 5/16 x 2" bolts with flat washer, lock washer and nut.

TRUNK LINER

- If you have not already done so, glue strips of flat rubber or plastic matting to the frame over the rear axle. This will provide sound insulation between the metal frame and the fiberglass or wood trunk liner.
- If not using the optional trunk liner, fabricate a cover out of 1/4" exterior grade plywood. Cut as necessary to fit over gas tank protrusion. Fit the two inserts in place and fiberglass perimeter to body.
- If using the optional factory fiberglass trunk liner insert into the rear of the car with the raised section over the fuel tank. Trim as necessary to fit.
- Place the two fiberglass inserts along each side and notch and trim as necessary to fit around the metal frame. Cut as shown.
- Using a rotary sander or an electric drill with a rotary sanding disc, sand away the gel coat in a 6-inch strip along the trunk liner and the two inserts. Also sand the forward edge where the trunk liner meets the floor pan. Sand the outer edges adjacent to the body. All areas where additional fiberglass will be applied must be sanded.
- Drill and bolt the trunk liner and the two inserts to the metal frame with 5/16 x 1" long, self-tapping, hexhead screws. Be sure screws have built-in washer surface or use flat washers between the screw and the fiberglass

surface to prevent the fiberglass from cracking.

- Attach gas tank cover to liner with 8 each 1/4 x 3/4 inch hex washer head self-tapping screws to allow access to sender.
- Cut out approximately 4-inch diameter

holes over the ends of the rear shock absorbers. Fabricate covers from thin wood or metal and screw into the trunk liner with small self-tapping screws.

NOTE: Holes provide access to the upper shock nuts to permit shocks to be replaced.

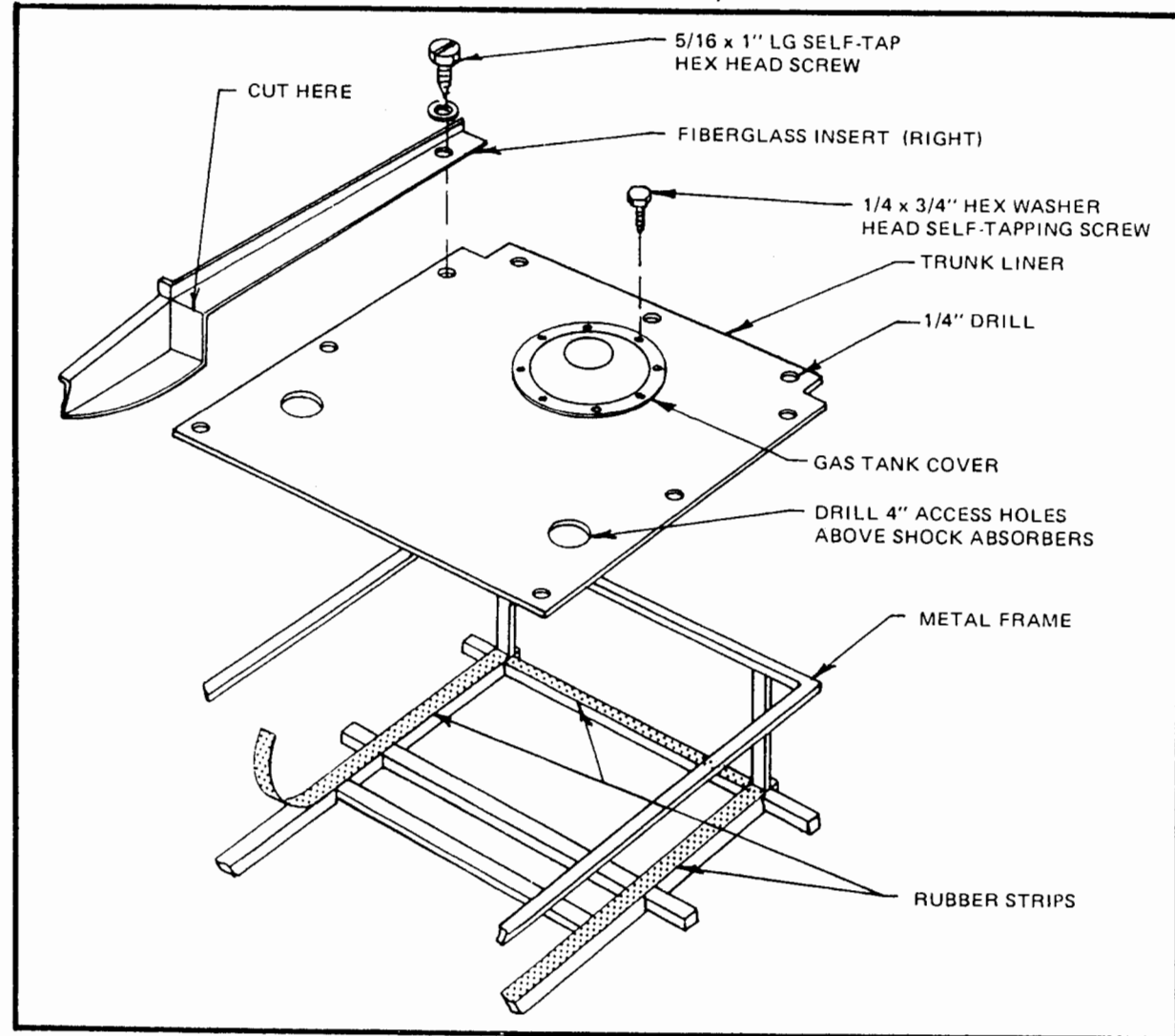

Figure 6

FUEL FILLER NECK (Refer to Figure 7)

- Cut a 2 1/2" hole through the edge of the trunk liner over the tank filler opening.
- Fabricate 1/2" plywood spacer as shown.

- On the back of the body, measure 3 1/2" down and 16 1/2" out from the center of the body. Cut a 2 1/4" hole at the marked location. Attach original Chevette filler neck in hole and secure with three No. 8 x 1 1/4" S.S. machine screws with flatwasher, lockwasher and nut. Connect filler

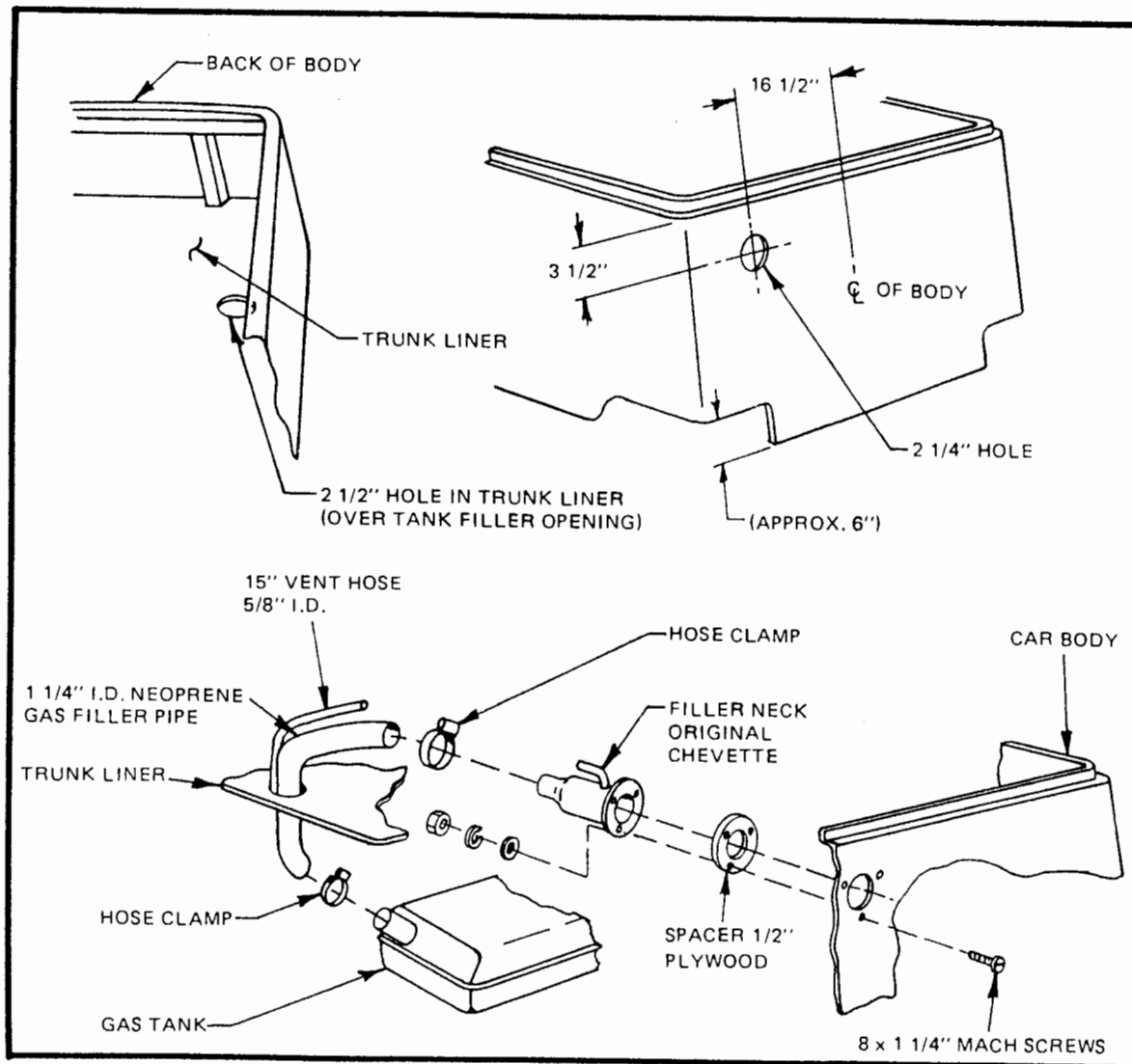

Figure 7

neck to tank with a length of 1 1/4" I.D. neoprene gas filler pipe. Secure with hose clamps. Glass around cut-out in liner.

DOOR CUT-OUTS (Refer to Figure 8)

- Cut out door opening leaving a 1" lip as shown. Round off upper edge. Save cut-out material in case you need fiberglass pieces at any time.

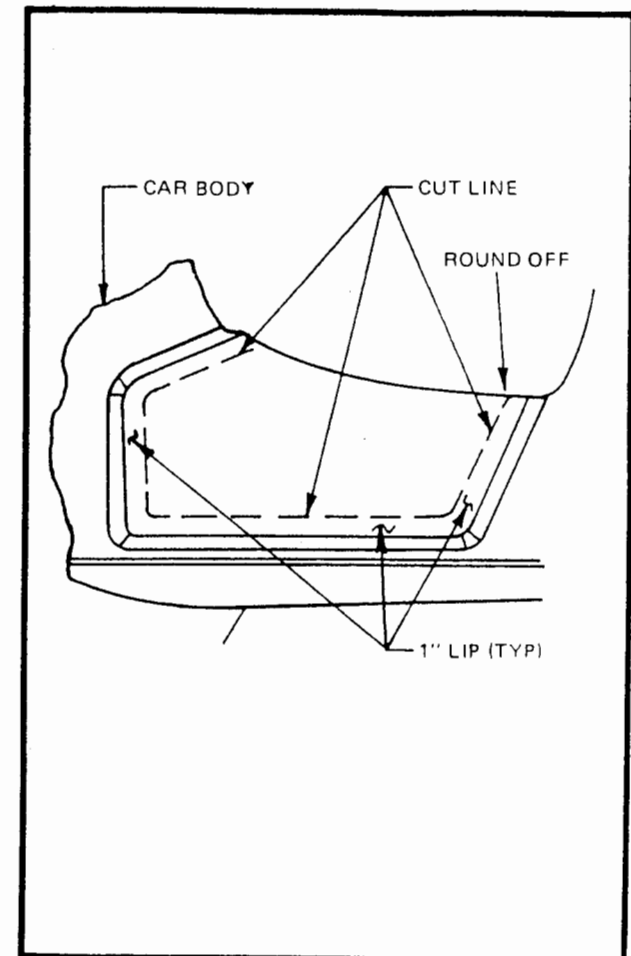

Figure 8

GLASSING THE BODY

- Check to be sure all gel coat has been removed from all areas to be glassed in.
- Vacuum up dust and debris from area to be glassed.
- First seal with fiberglass (Figure 9) Then cut two lengths of 2 x 4'' wood to fit under the door cut-out. They should extend from the frame member behind the door cut-out to the firewall (approximately 40''). Taper under door area as required.
- Cut a piece of 3/8'' plywood, 4 1/2'' x 12'' and glass in place in front of the door opening. This is to secure the door hinges.
- Cut strips of 6 and 12 inch wide glass matting to fit the areas to be glassed. When cutting to go around corners or where glass strips mate, you should allow an inch or two overlap between adjacent strips.

NOTE: Make sure rear fenders are straight and not sagging. If not, shim before glassing.

NOTE: When mixing resin do not add too much hardener. It will cause too much heat which can warp body.

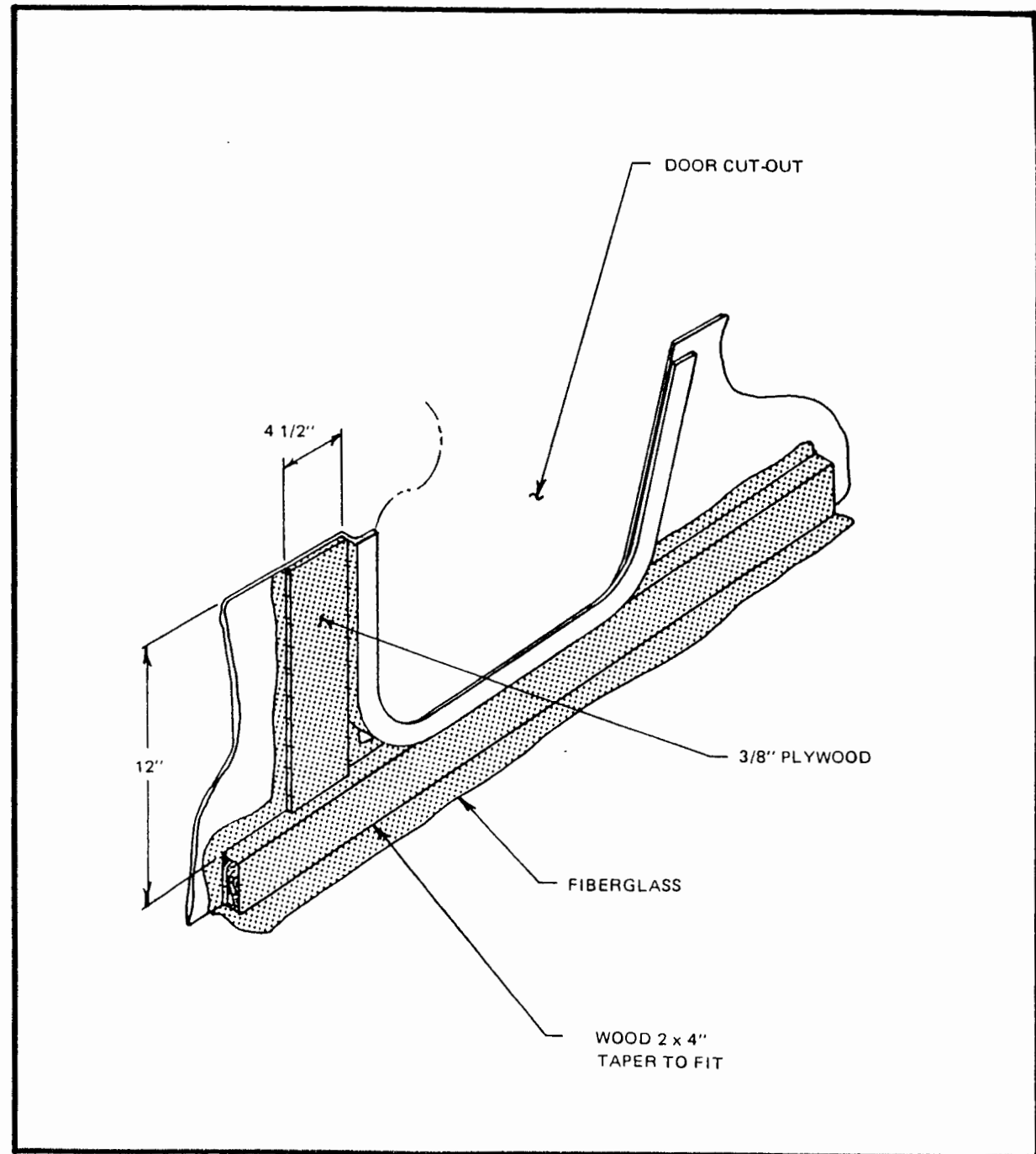

GLASSING THE BODY (Con't)

Areas to be glassed include:

- All around edges of floor pan and trunk liner.
- Joint between floor pan and trunk liner.
- Joints between floor pan or trunk liner and inserts along side.
- The 2 x 4's under the door cut-outs.
- Around fuel filler pipe.
- Front sides of body to firewall.
- Lay glass strips in place to check the fit. Where space permits, glass should extend about 6 inches up the side of the body and about 6 inches onto the surface of the trunk liner or floor pan.
- Mix resin and hardener according to manufacturer's instructions.
- Starting at one point, apply resin and fiberglass around the edge of the car. First saturate the area with resin, then lay in the fiberglass. Finally, brush resin liberally over the fiberglass until it is completely saturated.
- Bond fiberglass strips securely around steel frame members.
- Allow the resin to cure according to the manufacturer's instructions.

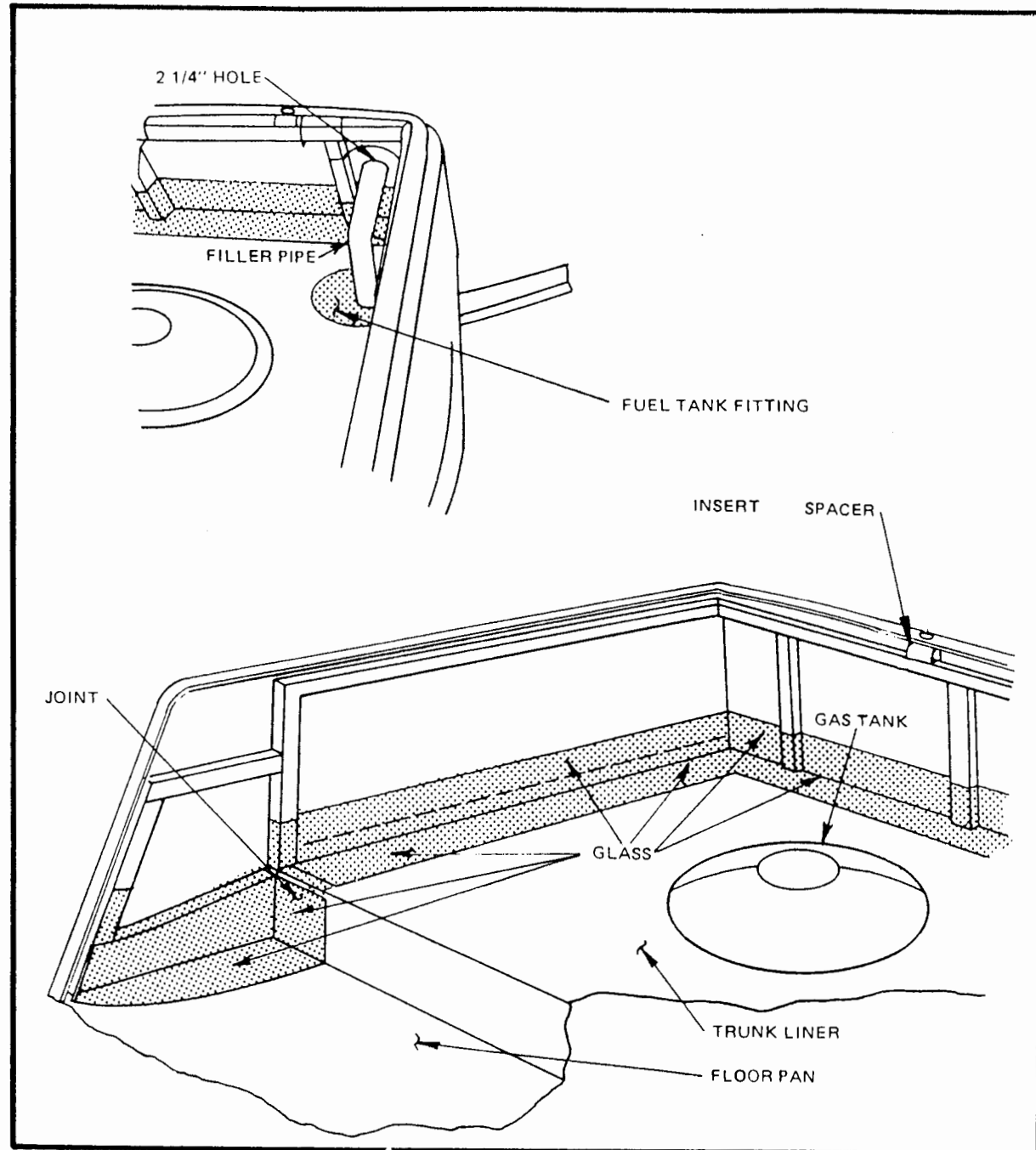

Figure 10

REAR SEAT AND REAR DECK LID ASSEMBLY

NOTE: This assembly consists of two parts, the rear seat and the rear deck lid.

- Seat the rear seat and rear deck lid in place, aligning the trunk lid with the body. The top edge of the rear seat should be hooked over the sides of the body.
- Trim and grind fiberglass as necessary to make seat and rear deck lid fit in place.

NOTE: If there is a space between bottom of seat liner and trunk liner, spacers will be used to fill this area.

NOTE: Upholstering and installation are described in a later section.

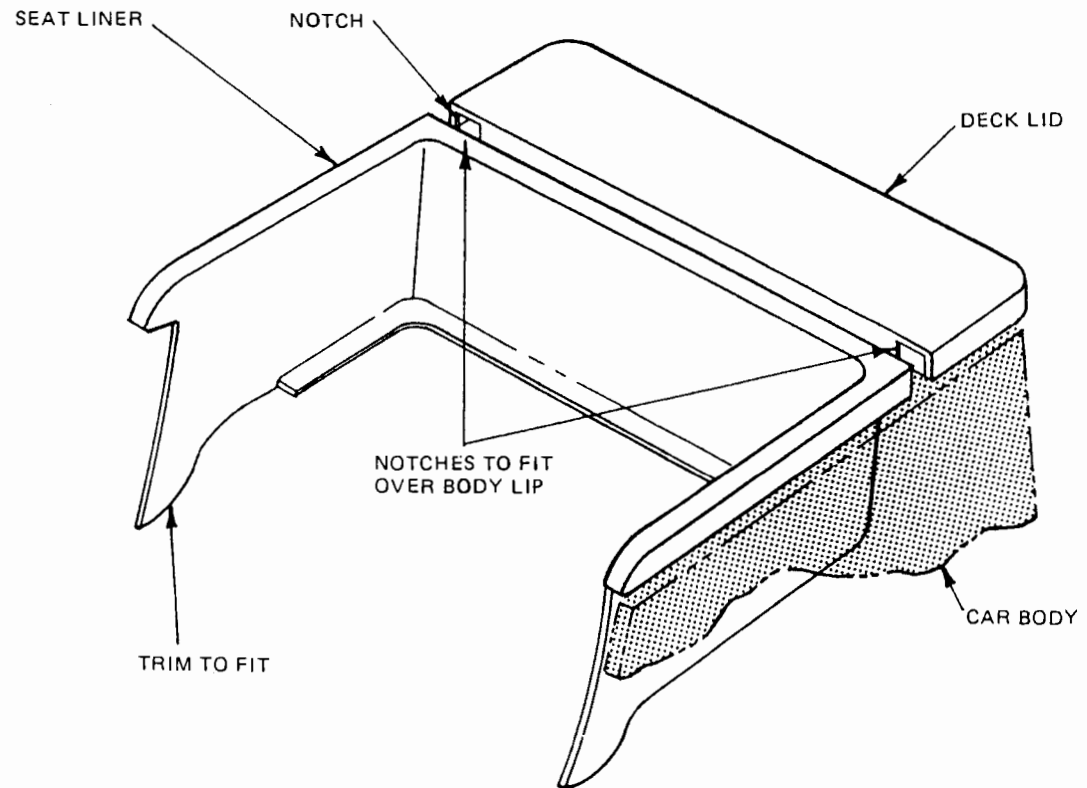

Figure 11

DOOR FABRICATION (OPTIONAL SLAM LOCK) (Refer to Figure 12)

- Fit the doors to the door opening by sanding and grinding as necessary. Make the doors about 1/4 inch smaller than door opening to allow for padded roll and upholstery. Door thickness should be approximately 1 1/8" all around.
- Obtain ten 8-32 T-nuts at a hardware store. Cut two pieces of 3/8" paneling 3 1/2 x 4" and two pieces of 3/8" plywood 2 1/2 x 10" to reinforce the door hinges.
- Place edge of lock with latch protruding in the center of the plywood against one 3 1/2" edge. Mark hole locations and drill three 9/64" holes through plywood. Mark latch hole center and cut or drill 7/8" hole through plywood. Drive 3 T-nuts into plywood and secure with three 3/4 No. 8 oval head machine screws.

NOTE: The door handles open the latch when pushed downward. The open end of the handle faces toward the front of the car at an upward angle. Mark lock assemblies left and right.

- Cut 1/2 x 1" notch in each door. The top of the notch is 5" from top of door side.

- Place lock assembly into position with latch protruding 1/2" through notch. Trim edges of plywood to fit, if necessary. Mark center of shaft location on fiberglass through shaft hole in plywood and lock. Drill a 7/8" hole through each door.
- Place handle with shaft through door and lock. Adjust so long edge of door mounting plate is in line with side of door. Mark hole locations and drill two 3/16" holes through door. Mark hole locations on paneling through holes in door and drill two 9/64" holes through paneling. Drive 8-32 T-nuts into holes.
- Reattach locks to paneling. Secure handles through doors into paneling with four 1" No. 8 stainless steel oval head machine screws. Cut shaft flush with inside of lock.

STANDARD DOOR LATCH (Refer to Figure 12, pages 5-12)

DOOR HINGES (Figure 13)

CAUTION: Use fiberglass sparingly. Too much resin in the area may warp or distort the door.

- Glass-in both the lock mounting plate and the hinge reinforcing plate. (Figure 13).

- Hinges are 4 1/2" apart. The bottom of the lower hinge is 2" from bottom of door. Bottom of upper hinge is 8" from bottom of the door.
- Drill 3/16" holes and attach hinges to the edge of door, secure with No. 10 x 1" stainless steel oval head screws with flat washer, lock washer and nut. Cut screws flush at nut.
- Test fit doors to body. If there is any binding due to construction variances, bottom edge of door and upper front door sill can be ground until correct fit is obtained.
- Cut a sheet of 1-inch thick Styrofoam (available at lumber yards and home improvement stores) to fit the inside of the door. Notch out and trim as necessary to clear the hinge plate and the slam lock. When properly fitted, the foam should be flush with the edge of the door flange.
- Glue the foam into the door using 3M "77" brand spray adhesive.
- Test fit the door upholstery cover to the door. Then attach to the foam with 3M "77" brand spray adhesive.
- Stretch the door upholstery to fit and glue the edges with Super Glue adhesive or its equivalent.

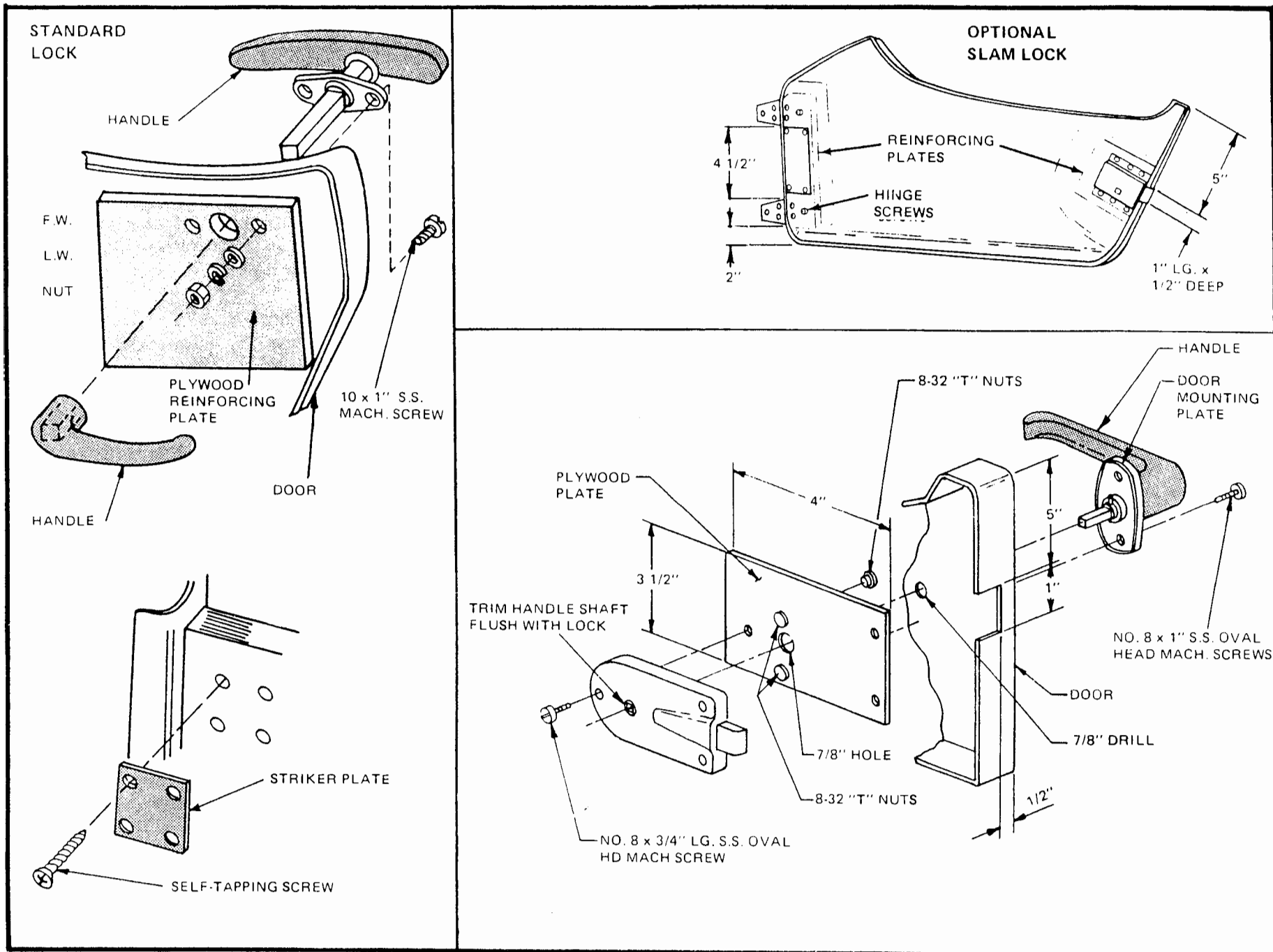

Figure 12

DOOR INSTALLATION (Refer to Figure 13)

- Mount finished door in place with latch and hinges attached.
- Place 1/8-inch spacers around edge of the door between the door and the door frame. Use washers to get correct fit.
- Mark the position of the hinges and striker plate and drill and install, using No. 8 x 1 1/4" stainless steel oval head machine screws with flat washer, lock washer and nut.
- If necessary grind lip of fiberglass body so nuts clear.

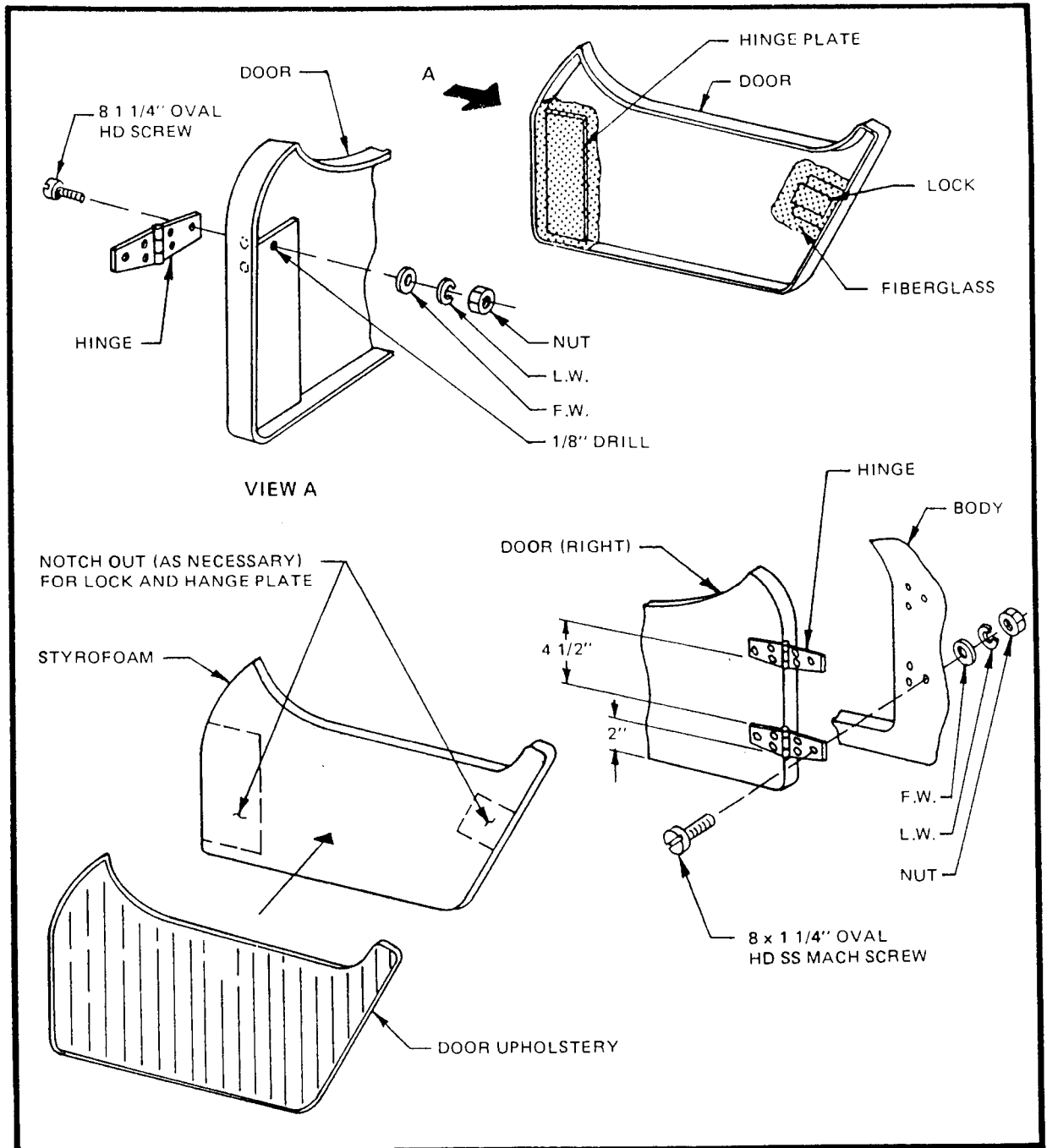

Figure 13

**RUNNING BOARD BRACKETS
(OPTIONAL) (Refer to Figure 14)**

- After fitting the body, clamp the two running board brackets against the frame member.
- Locate the brackets so that same spacing exists between the rear of front fender and the front of rear fender.
- Mark hole locations and drill 5/16" holes. Bolt the running board brackets to the frame, using 5/16 x 1 1/2" bolts with flat washers, lock washers and nuts.

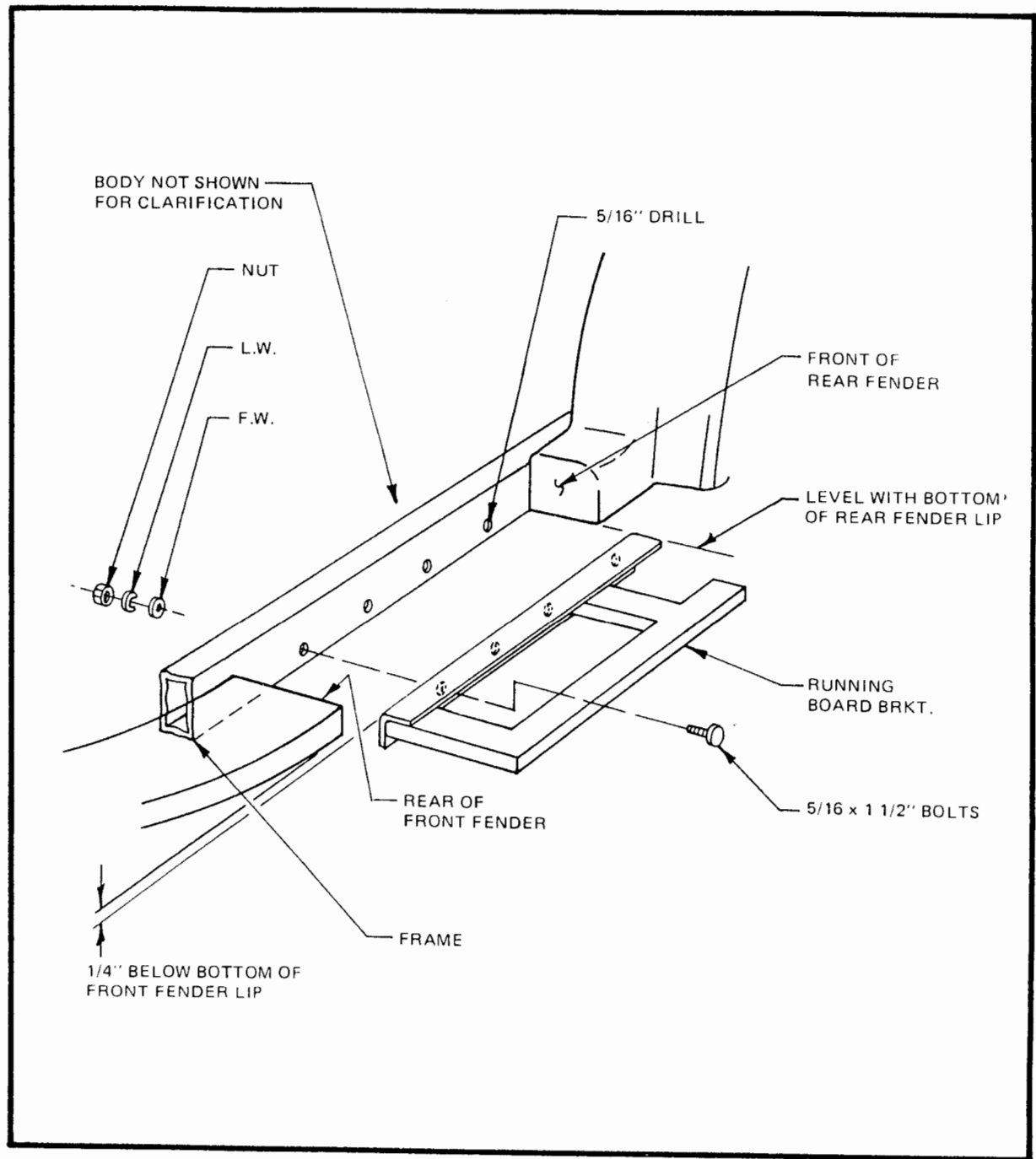

Figure 14

RUNNING BOARD (OPTIONAL)

- Using a piece of cardboard, cut a template to fit the running board area between the two fenders. Spacers should be used to elevate the cardboard to the level of the plywood sheet. You may also need to add spacers under the plywood sheet to get the best position.

NOTE: Cut template for each side. There may be slight variations in dimensions depending on how you located the fenders.

- Transfer the templates to the pieces of 3/4 inch wood, 9-5/8 x 31 inches.
- Measure the approximate angle of the slope of the fenders at the intersections of the running board and fenders with a protractor or similar measuring tool. This angle is approximately 60 degrees.
- Set the approximate angle on a saber saw and cut the plywood along the template line, at the measured angle.
- Trim and sand as necessary to get a good fit.
- Drill through the wood and running board bracket. Countersink holes for bolts into the plywood, 5/16 x 1 3/4".
- Remove the plywood and cut black rubber matting to fit the plywood.
- Glue or staple welting along the inside edge of plywood.

- Fasten the plywood securely to the running board bracket with 5/16 x 1 3/4" bolts with flat washer, lock washer and nut.
- Fill the bolt holes with wood filler or similar material and glue the black rubber

matting in place with automotive trim adhesive.

- Trim and fasten the aluminum strip to the outer edge of the running board with 3/4" No. 4 oval head self-tapping screws.

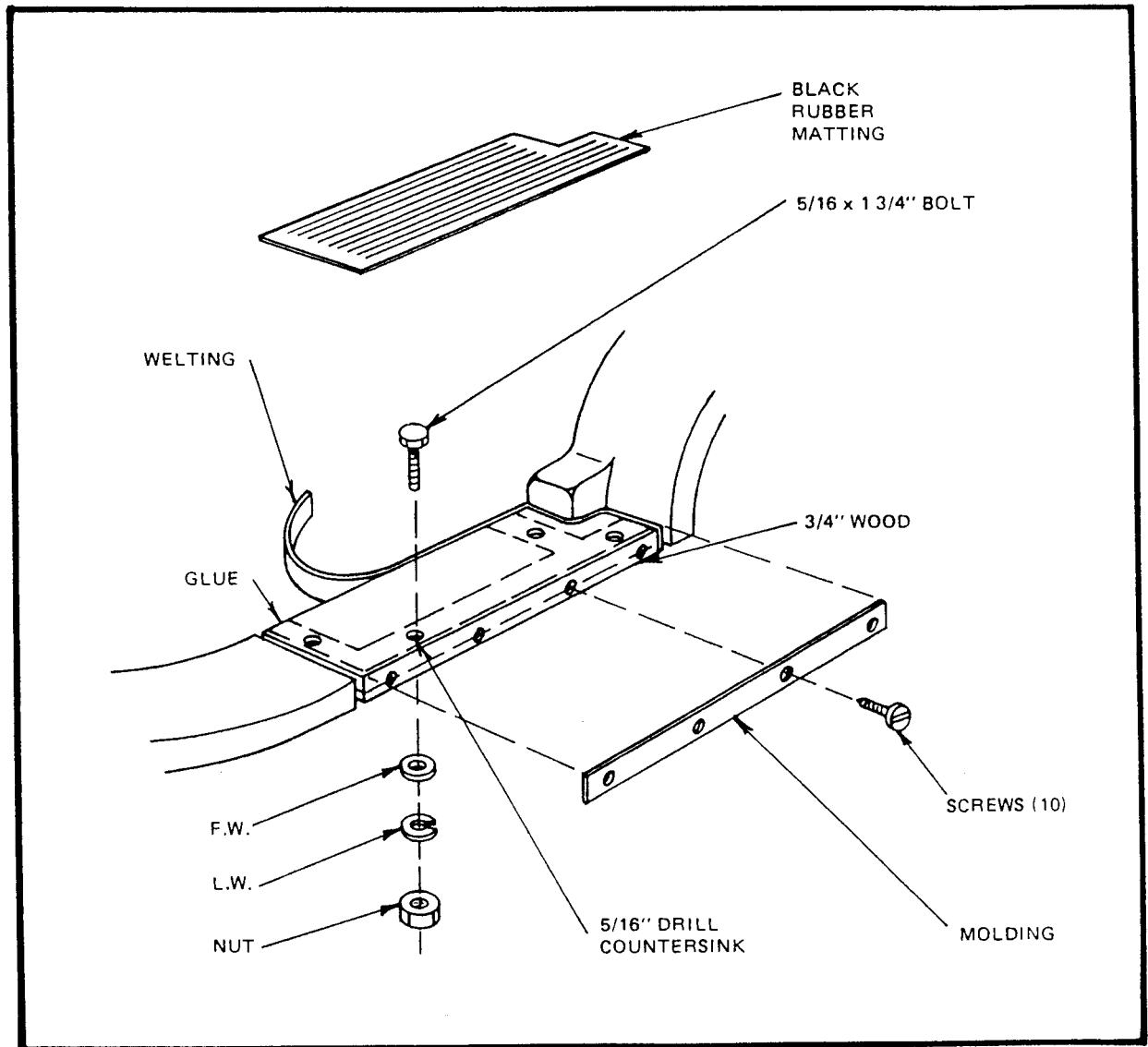

Figure 15

FRONT BUMPER (STANDARD) (Refer to Figure 16)

- Place the front bumper on the front bumper bracket.
- Locate the studs on the bumper through the tabs on the front bumper bracket and attach with nuts.

NOTE: Do not overtighten nuts holding bumper.

FLAT BAR (OPTIONAL)

- Thread studs into bumper support clamps and bumper supports.
- Place bumper in position with studs going through holes in bumper bracket extension.
- Thread lock nuts provided onto studs. Align bumper and tighten nuts.

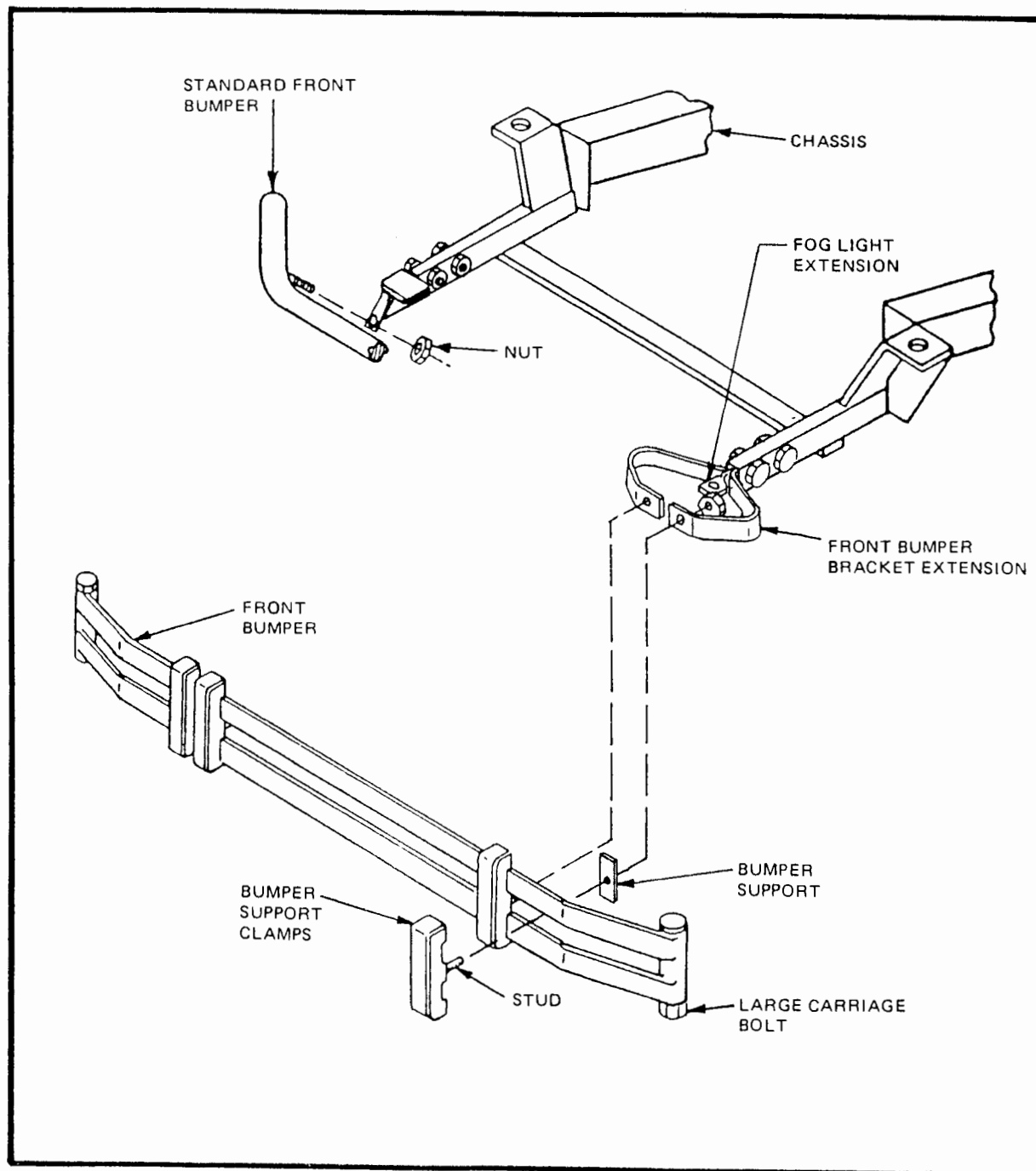

Figure 16

REAR BUMPERS AND COVERS

- Glue short strips of rubber or vinyl to the top of the bumper brackets. (Figure 17). These will act as a cushion for the bumper bracket covers.
- For flat bar bumpers drill 1/4" holes into the sides of the brackets and install the bumper bracket cover support tabs using 1/4 x 1 1/4" bolt with flat washer, lock washer and nut.
- Fit the left and right covers to the body and mark for trimming with a grease pencil.
- Sand or grind the inner edge to fit against the body.
- Sand or grind the outer bottom edge, but leave a small (1/8-inch) lip.
- Glue welting to the inside edge of the covers where the covers mate to the body.
- At the corners of the bumper bracket covers, trim away the welting leaving only the bead. (Figure 17) Then bend the bead down along the edge and glue it in place with "Super Glue" adhesive or equivalent.
- Drill two 1/4" holes through the covers and brackets and secure the covers to the brackets with 1/4 x 2" chrome carriage bolts with flat washer, lock washer and nuts.

CAUTION: Do not overtighten or you may crack the fiberglass covers.

- Position the two rear bumpers in place and tighten the nuts on the tabs. (Refer to Figure 3, page 5-3).

NOTE: Do not overtighten nuts holding the bumper.

- Using epoxy, install the chrome bumper end caps. (Standard bumpers only)

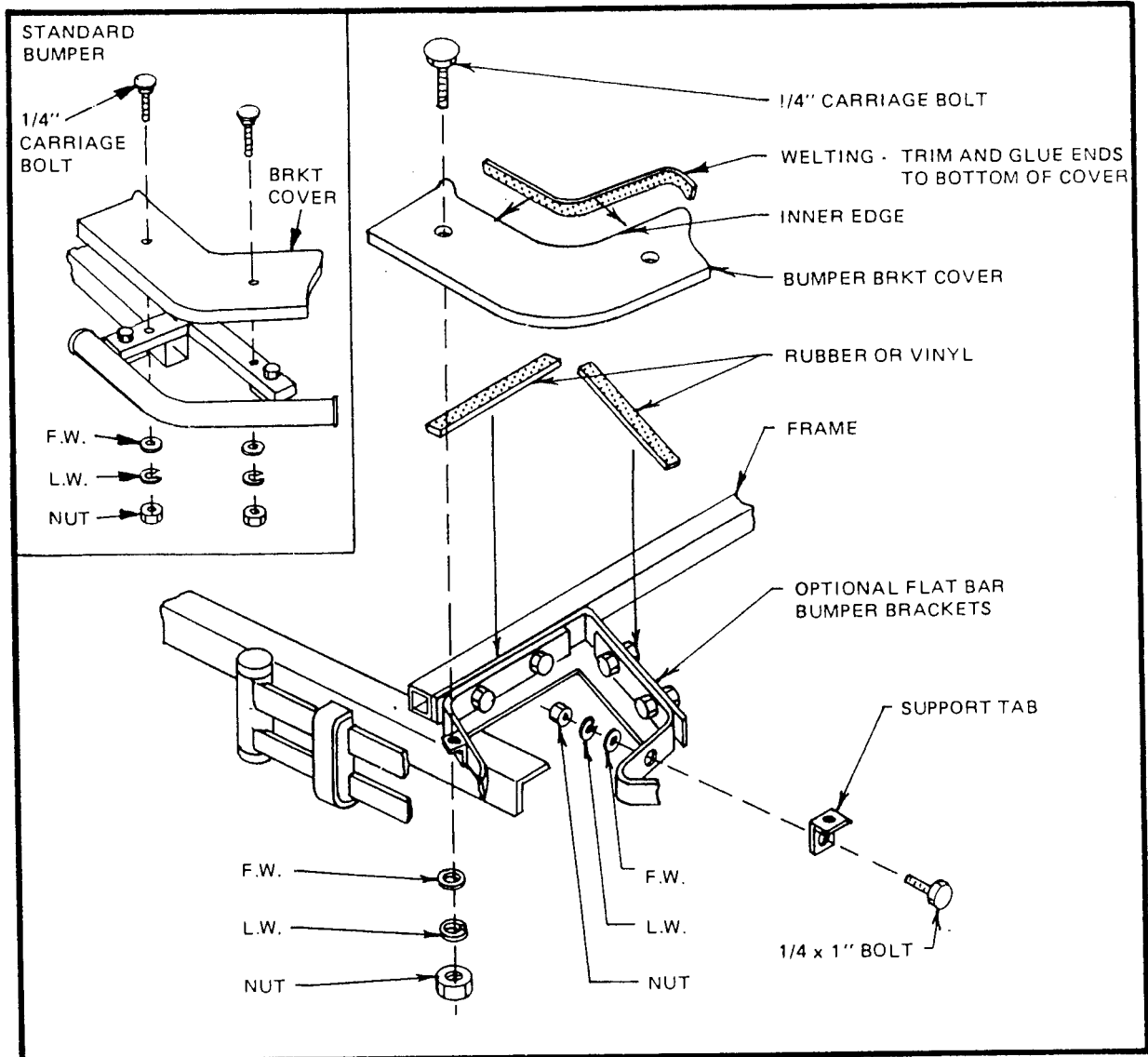
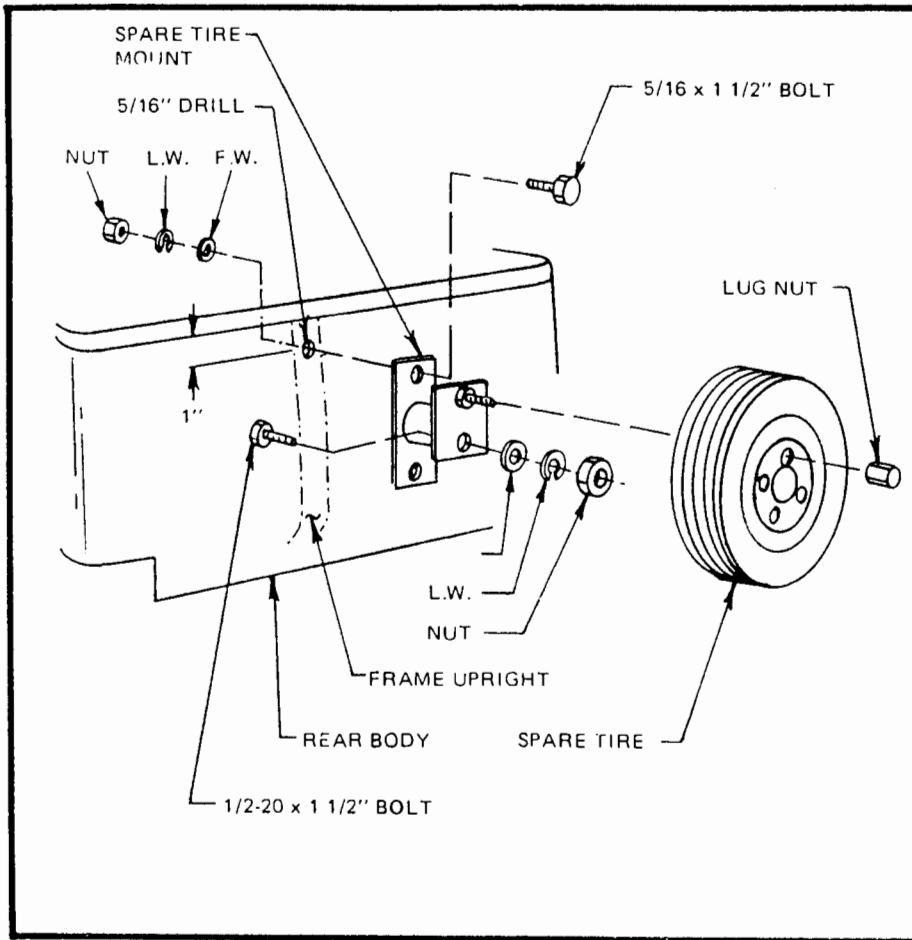

Figure 17

SPARE TIRE MOUNT

- Position the spare tire mount in the center of the rear body (Figure 18)
- Locate the top of the spare tire mount bracket approximately 1 inch below edge of trunk as shown in Figure 18.
- Drill through body and rear center upright frame member and attach with bolts, nuts and lock washers.
- If there is a space between body and frame upright shim with washers.
- Measure the distance between the opposite holes on the spare and transfer this dimension to the bracket. Drill 1/2" holes in the bracket and insert 1/2 x 20 x 1 1/2" bolts into bracket and secure with lock washer and jam nut. Install tire and attach lug nuts.



(Figure 18)

BACKUP LIGHTS (Figure 19)

- Mark the position of the (optional) back-up lights using the rubber gaskets as templates. Bottom of light is just above bumper bracket cover. Outside edge of light is 3" in from side of body.
- Drill through the fiberglass body and attach the lights to the body with the hardware supplied.

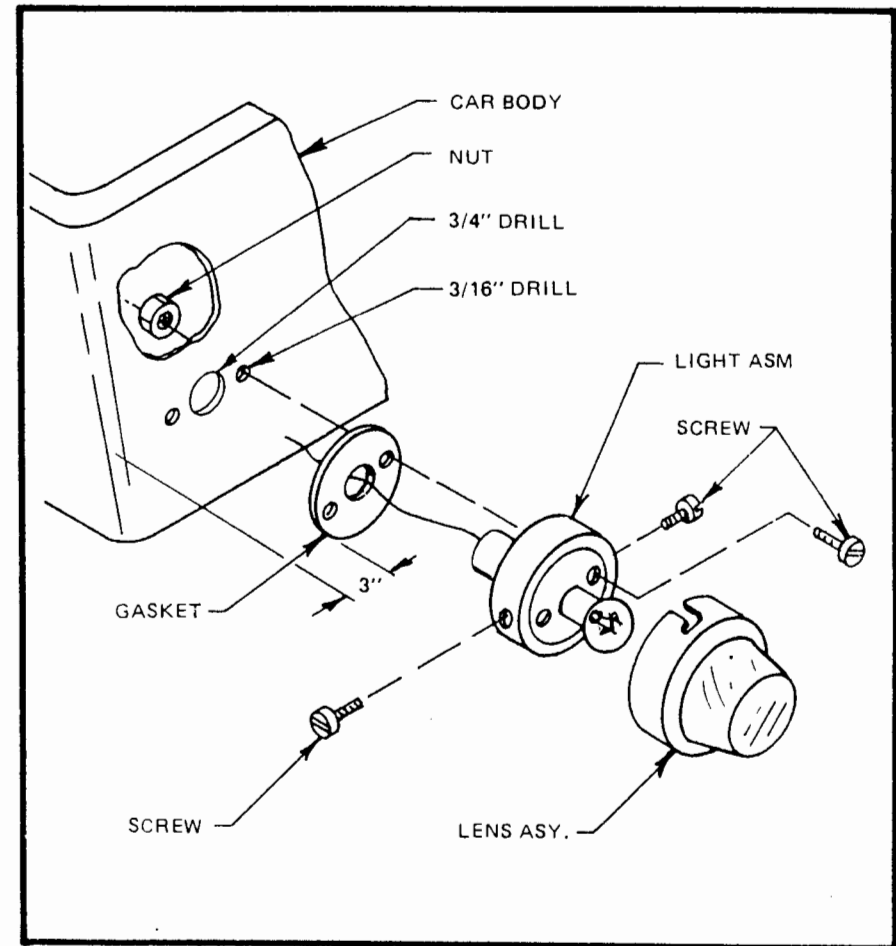

Figure 19

CHROME LICENSE ASSEMBLY

(Refer to Figure 20)

- Mark the position of the chrome license assembly on the right rear side of the body. Locate as shown.
- Drill 1/4" holes through the fiberglass body and attach the assembly to the body with 1/4 x 1" hex head machine screws with washer, lock washer and nut.

FRONT FENDER BRACKETS

(Refer to Figure 21)

- Bolt the front fender brackets to the tabs welded to the top of the frame using 1/2 x 1" bolts with flat washer, lock washer and nut. Tighten finger tight.

BADGE BAR AND HEADLIGHTS

- Bolt the fender brackets to the frame.

- Bolt the headlight support brackets to the fender brackets. Tighten finger-tight.
- Bolt the badge bar to the headlight support brackets with the headlight assemblies. Tighten finger-tight.
- If used, install the optional headlight cable covers over the wires to the headlights.
- Secure the cable covers by threading on headlight stud. Drill 7/16" hole at back sides of frame horns and insert flex cables. File holes until tight fit is obtained.

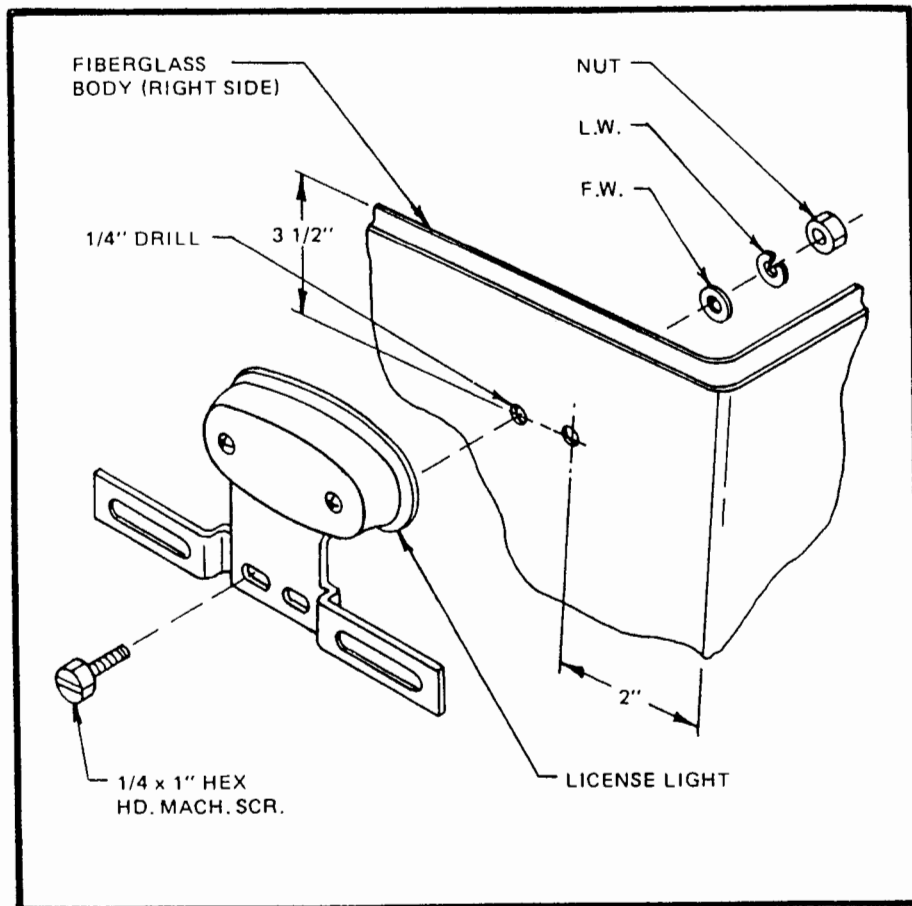

Figure 20

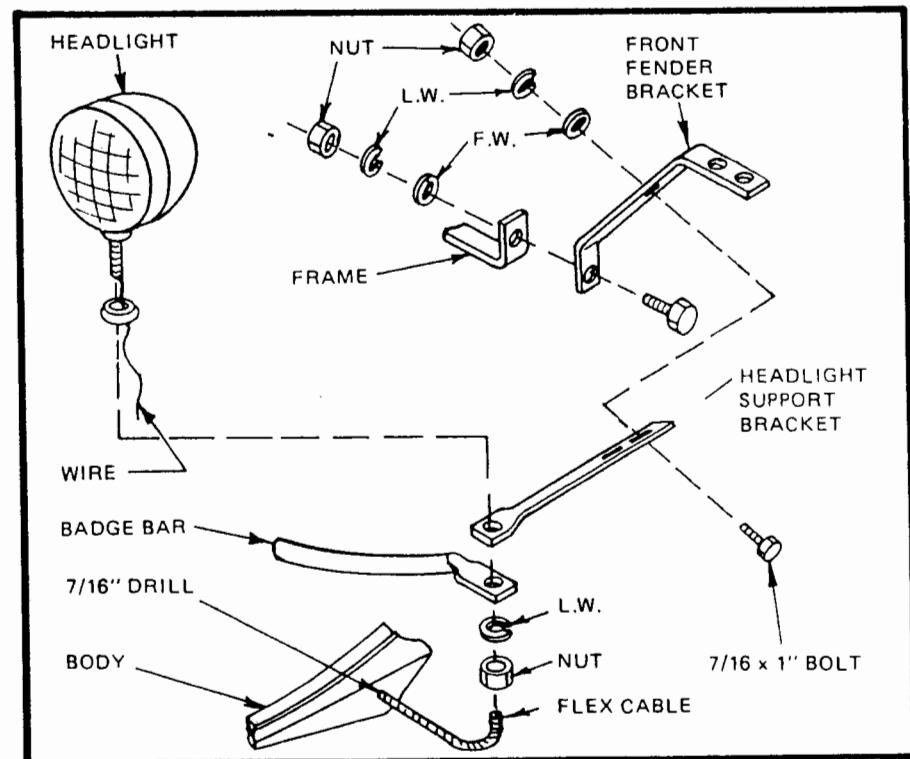

Figure 21

TRUMPET HORNS (OPTIONAL) (Refer to Figure 22)

- Align the headlight and badge bar assembly.
- Mark the positions of the horn assemblies.
- Drill $3/16''$ holes and attach the horns to the fiberglass body, using a No. 10 x $1\ 1/4''$ machine screw with flat washer, lock washer and nut. Drill a $1/4''$ hole for wires.
- Position the horn supports on the badge bar and screw or rivet the supports to the badge bar.

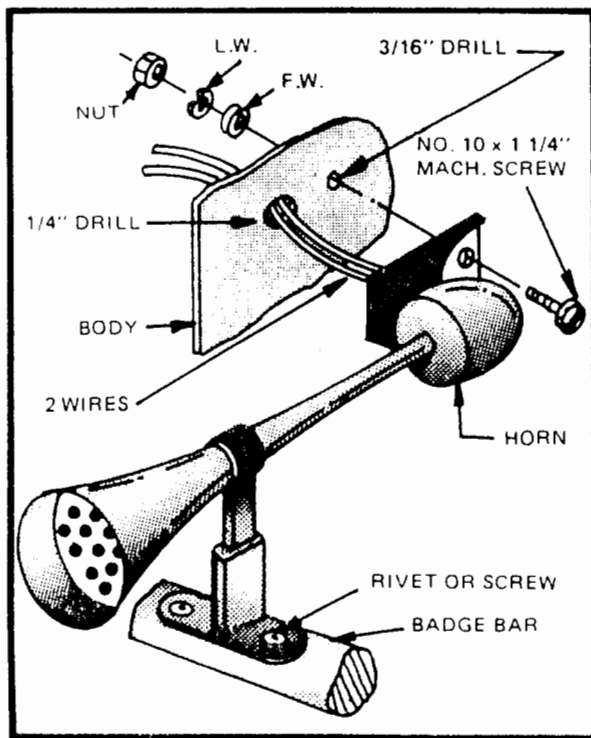

Figure 22

FINAL ALIGNMENT (Refer to Figure 23)

- Align all components for best visual position.
- Drill 2 holes, $5/16''$, through the top of the fender and into the fender brackets. Secure with $1/4 \times 2''$ carriage bolts with flat washer, lock washer and nut. It may be necessary to use rubber spacer or washers between fender and bracket.
- Tighten the fender bolts, headlight bracket bolts, headlight nuts, and horn bolts.

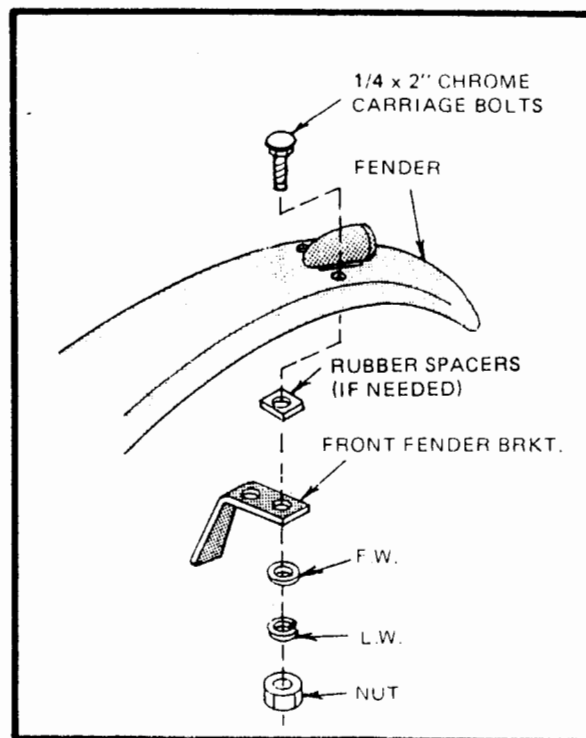

Figure 23

OPTIONAL BADGES (Refer to Figure 24)

- Attach badges to badge bar with clips. Align and tighten securely. Shim with rubber for tight fit.

FOG LIGHTS (OPTIONAL)

- Install fog lights on the plate between the bumper and the fiberglass horns. Drill a $3/8''$ hole and secure fog lights with hardware provided.

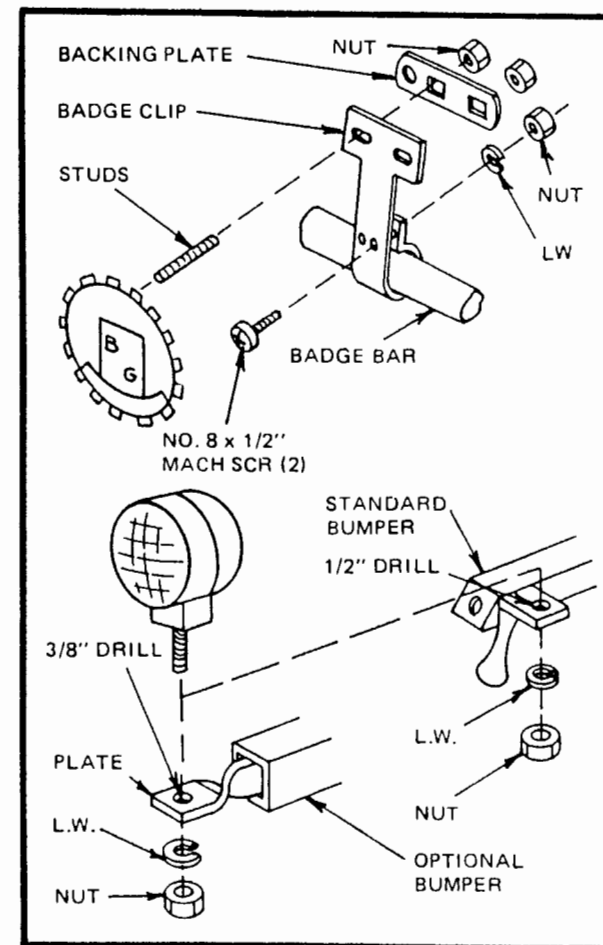

Figure 24

UPHOLSTERY

In this section, you will install seats and carpets and will need 3M "90" spray adhesive and a good pair of scissors and some straight edge razor blades.

- Seats are best assembled on a large workbench or table of convenient height. You should cover the workbench with carpet remnants or similar material to protect the upholstery while you are working on the seats.
- Illustrations and instructions in this section contain some plywood and foam not supplied with your assembly. If you wish to use extra foam, it's available at your local auto upholstery supply house. However, the foam supplied with your assembly is adequate.

CARPETING

- The carpeting kit consists of seven pieces as shown in Figure 1. Lay out the pieces on the floor and check to be sure you have unpacked all the pieces.

NOTE: Finished edges on the carpet are designed to be visible in the car. Unfinished edges are concealed by other parts and may have to be trimmed to fit.

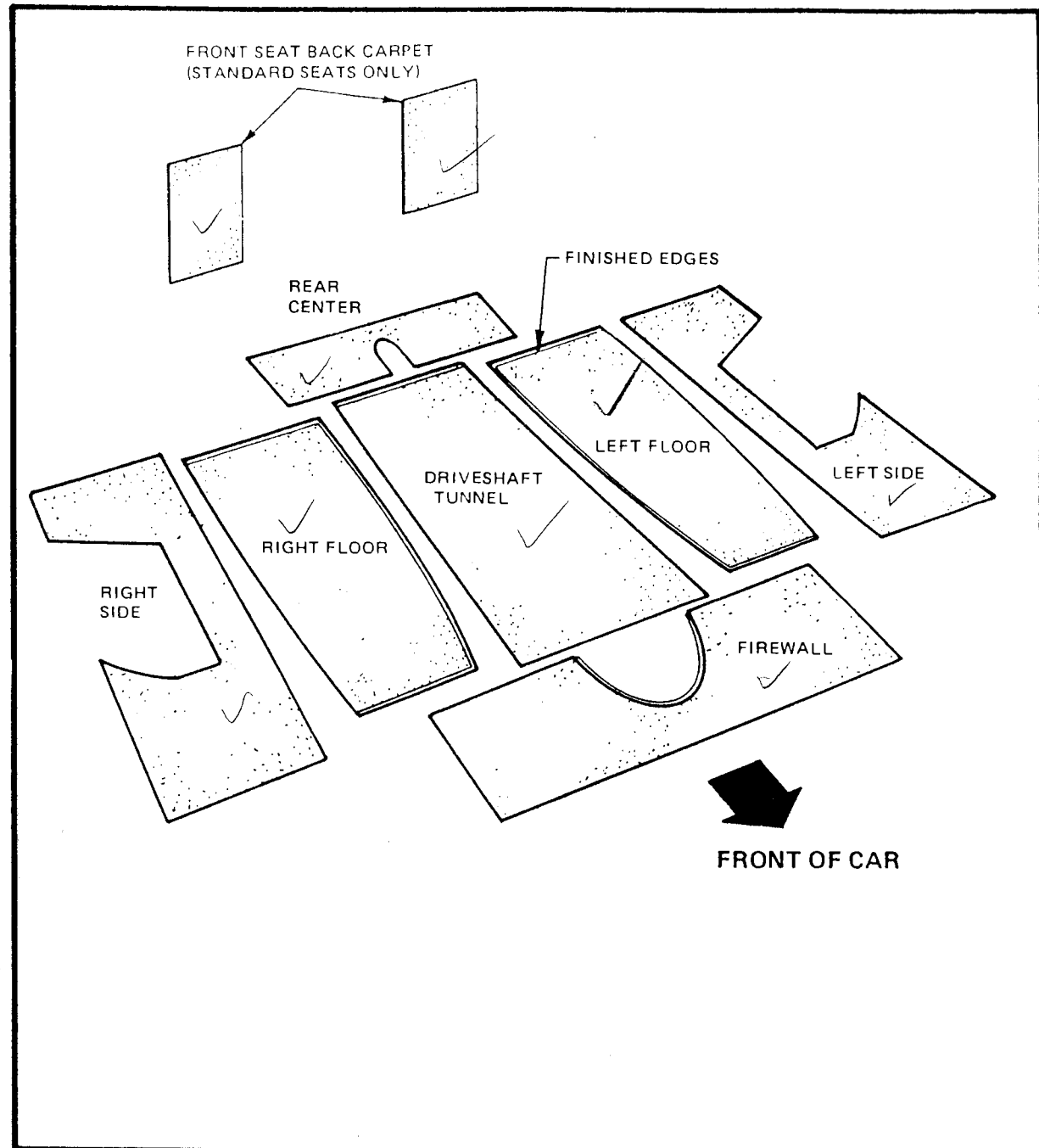

Figure 1

CARPETING (Con't)

- Position the first piece up against the firewall. Orient lower finished edge to fit where floor pan starts to angle upward toward the firewall.
- Cut and trim the carpet as necessary to fit around the accelerator pedal and the dimmer switch.

NOTE: Carpet is secured in place with a spray carpet adhesive such as 3M "90" brand spray adhesive. This adhesive is sprayed on the back of the carpet and the surface to which it will be cemented. Allow the adhesive to air-dry for about 30 seconds, then press in place. If necessary, the carpet can be picked up and moved to get a better alignment. You can also use contact cement, however, you have less capability to move the carpet in case of misalignment.

- Apply the adhesive to the firewall and to the back of the carpet and press in place.

NOTE: Don't spray the lower finished edge so that you can slip the other pieces underneath.

- Trim off any excess.
- Install rear seat carpet and allow to extend 1 1/2" on to floor. Glue in place.

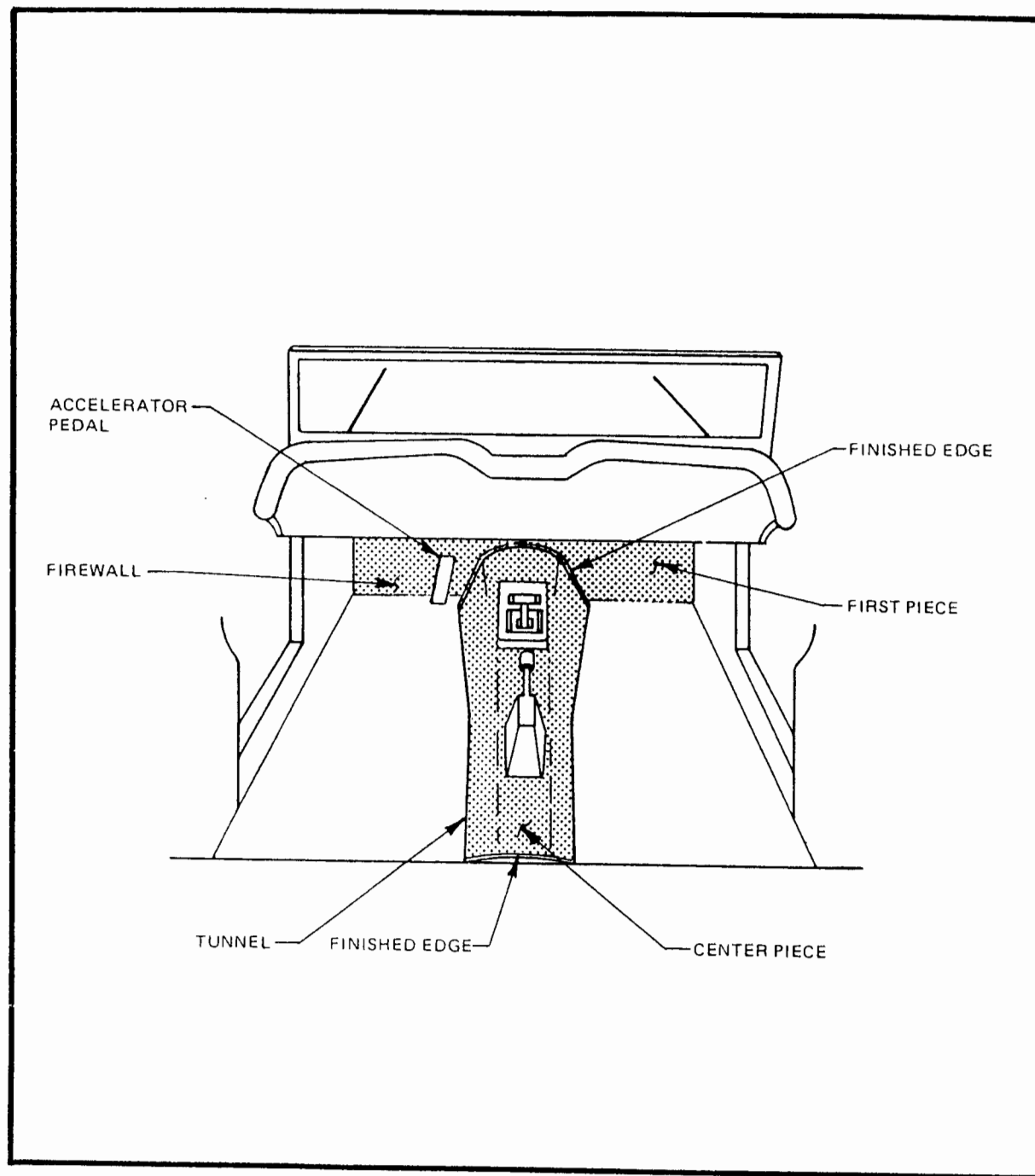

Figure 2

CARPETING (Con't)

- Position the center piece over the drive shaft tunnel. Slide the rear edge up to the corner at the rear of the drive shaft tunnel.
- Glue down the section behind the parking brake handle.
- Cut out an opening for the parking brake handle and another for the gear shift mount. Apply the spray adhesive and glue this section in place.
- Finish cementing the remainder of the strip to the drive shaft tunnel.
- Trim the end as necessary and tuck the end under the firewall section.
- Install side carpet. Trim flush with door edge. Allow bottom to extend several inches onto floor.
- Install the left and right floor segments and trim along the outside edges.

NOTE: After installation of the rear seat, the trunk can also be carpeted using remnants.

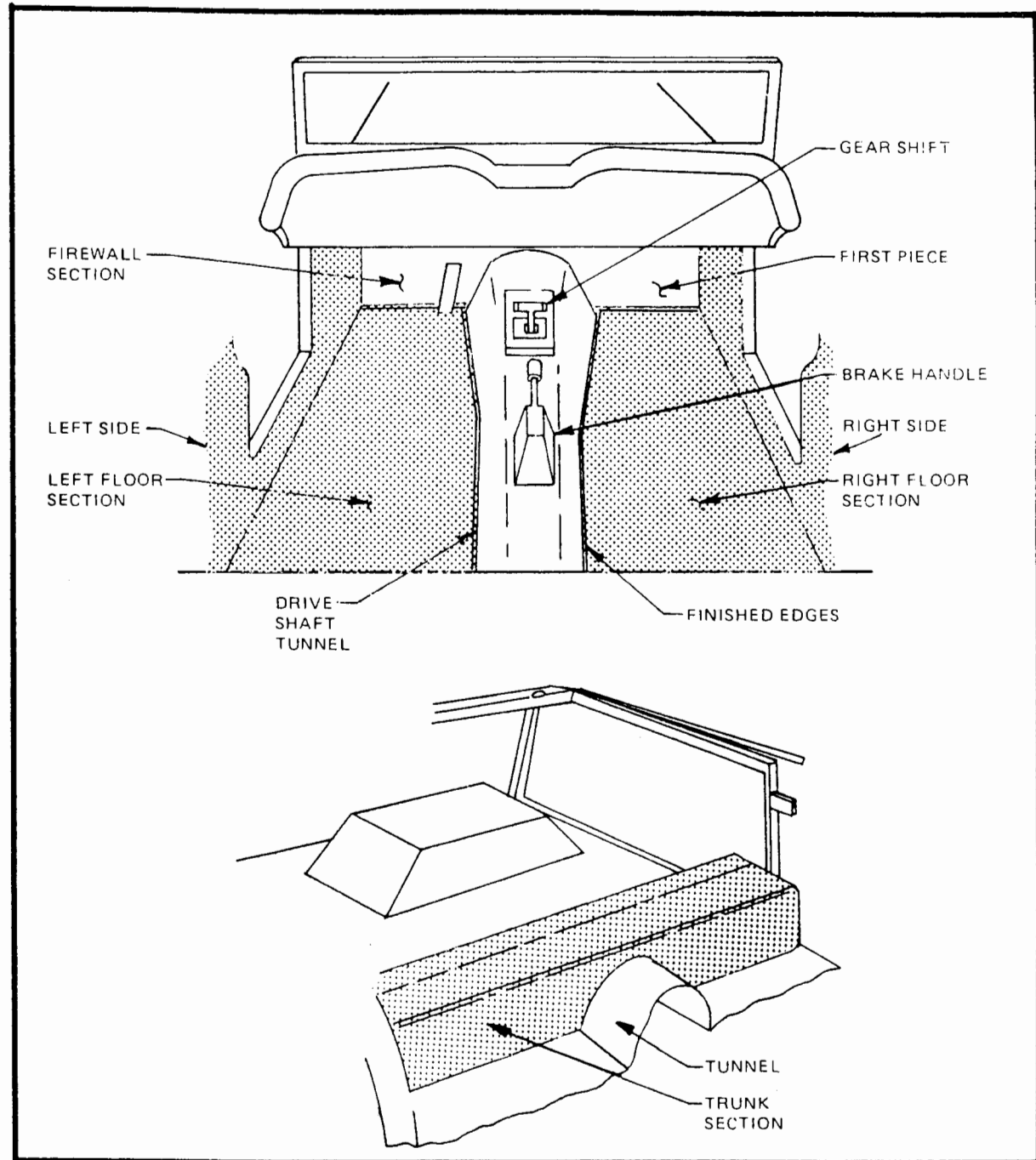

Figure 3

REAR SEAT

- Recheck the fit of the rear seat liner. The upper edge of the seat liner should fit snugly over the top edge of the body with the side ends against the top of the door cut. The bottom lip of the seat liner should rest on floor. If there is a space, shim with plywood strips. Trim seat liner to get the best fit possible.
- Using No. 10 x 3/4" round head wood screws attach strips of 3/8" plywood, 1/2" wide, all around the inside of the fiberglass seat. (Figure 4) This strip provides a surface to which the upholstery can be stapled.
- If rear speakers are to be installed, cut holes in fiberglass at the desired location.
- Cut 1" foam padding for seat liner. Cut three pieces, one for each side and rear. Foam should extend to outer edge of upper lip on seat liner and even with the plywood strips at back and sides.
- Sand off all sharp edges around sides and back of fiberglass shell. Sharp edges may cut the upholstery fabric.
- Using 3M "90" brand spray adhesive, glue foam sheets to the fiberglass surface.
- Wrap the foam around to the top edge of the rear seat assembly.
- Trim about a half an inch of foam off the top front edge.

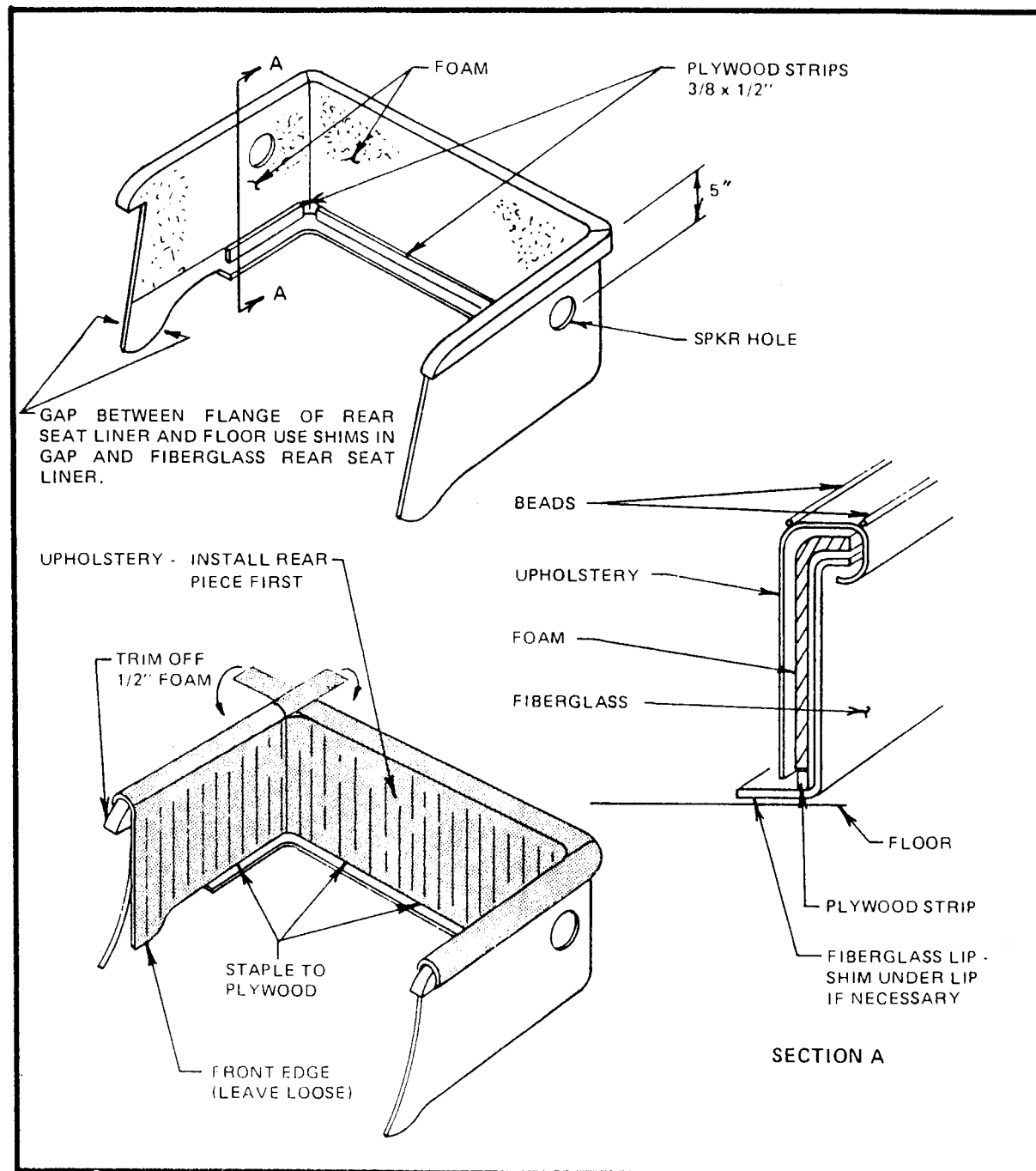

Figure 4

- Slip the rear seat upholstery over the seat padding and check the fit. You can glue additional strips or pieces of foam wherever necessary to make the upholstery look and feel the best.
- Staple the upholstery to the plywood strips. (Figure 4) Start at the center of the back and work outward in each direction.
- Stretch the top flap over the edge of the fiberglass and cement on the underside with spray adhesive.
NOTE: Leave the front edges loose until after the seat is installed.
- Place the seat liner into the car and position the seat fully back against the trunk liner. Fit the rear deck lid in place to check the fit. Adjust position of seat liner to allow deck lid to fit properly.
- Shim space between rear seat liner flange and floor liner.
- Attach the seat to the frame with No.10 x 2" phillips oval head self-tapping screws.
- Glass-in the seat to the trunk liner in the back around the trunk area. Also fiberglass rear seat liner flange to floor liner.
- Install rear seat belts by bolting through the trunk liner and through the frame members.
- Pull front edge of upholstery forward and glue to body, keeping upholstery taut.
- NOTE: You can use the seat belts removed from your Chevette.

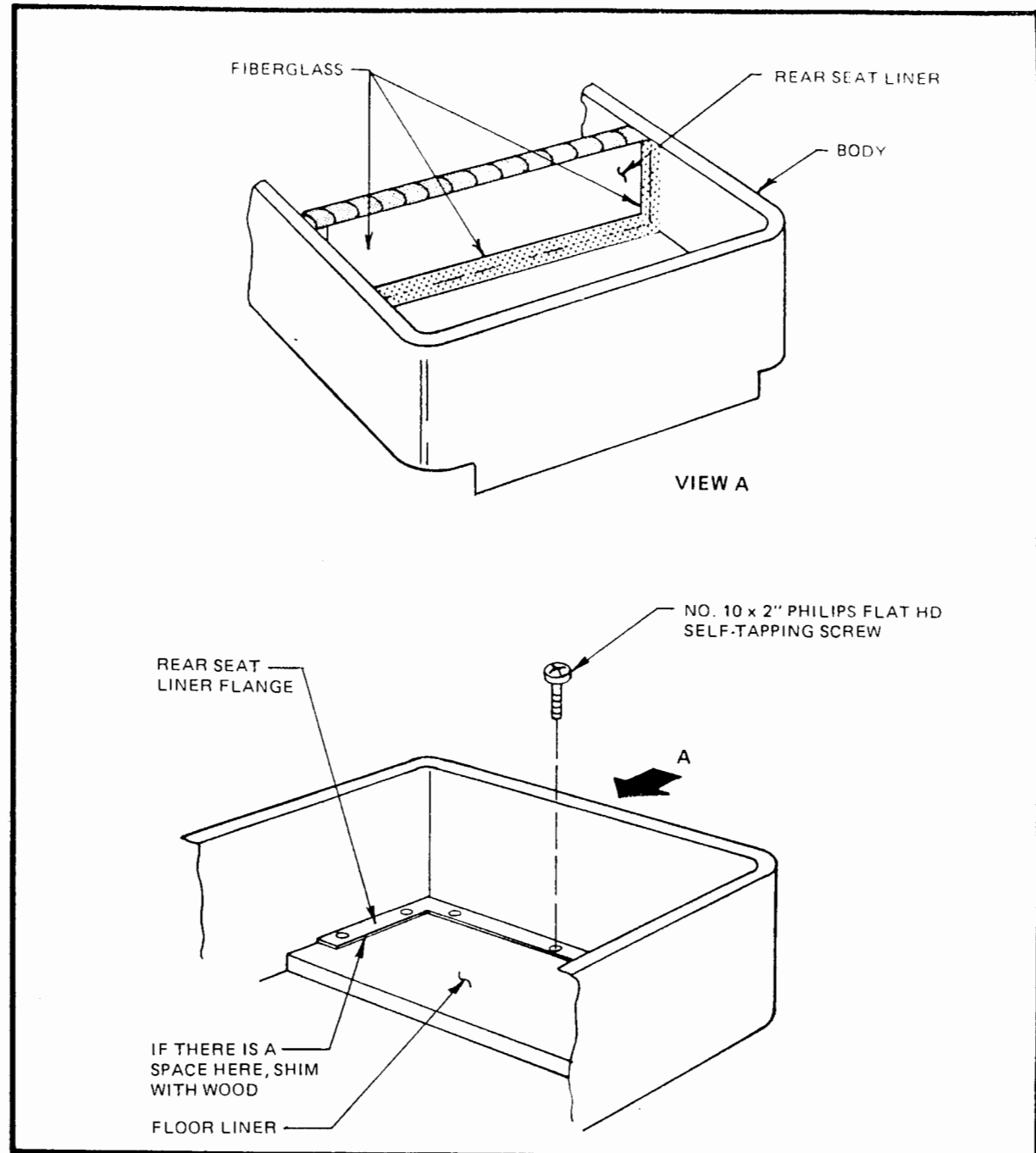

Figure 5

REAR SEAT CUSHION

- Cut a piece of 1/2" inch plywood as shown in Figure 6.
- Trim the plywood to fit the rear seat floor area.
- Cement a 2-inch thick block of foam padding to the plywood using 3M "90" brand adhesive.
- Roll the front edge of the seat cover upholstery back and staple the seam down to the plywood along the edge of the 2-inch thick foam block.
- Slip the seatcover over the back of the board and pull taut and staple.
- Cement a 4-inch thick strip along the front edge of the rear seat cushion between the staple line and the front edge of the plywood.
- Pull the upholstery forward over the 4-inch foam strip and staple the edge securely on the underside of the plywood.
- Place the seat cushion on the rear deck and push it firmly in place. It will be held in place by the padded upholstery.
- Spray adhesive on the side pieces which extend forward from the side of the rear seat upholstery.

- Pull upholstery forward and cement flap on the inside edge of door. Trim off the excess material. Fig. 6 shows the

details. Glue trim strip of upholstery over door edge for finished appearance.

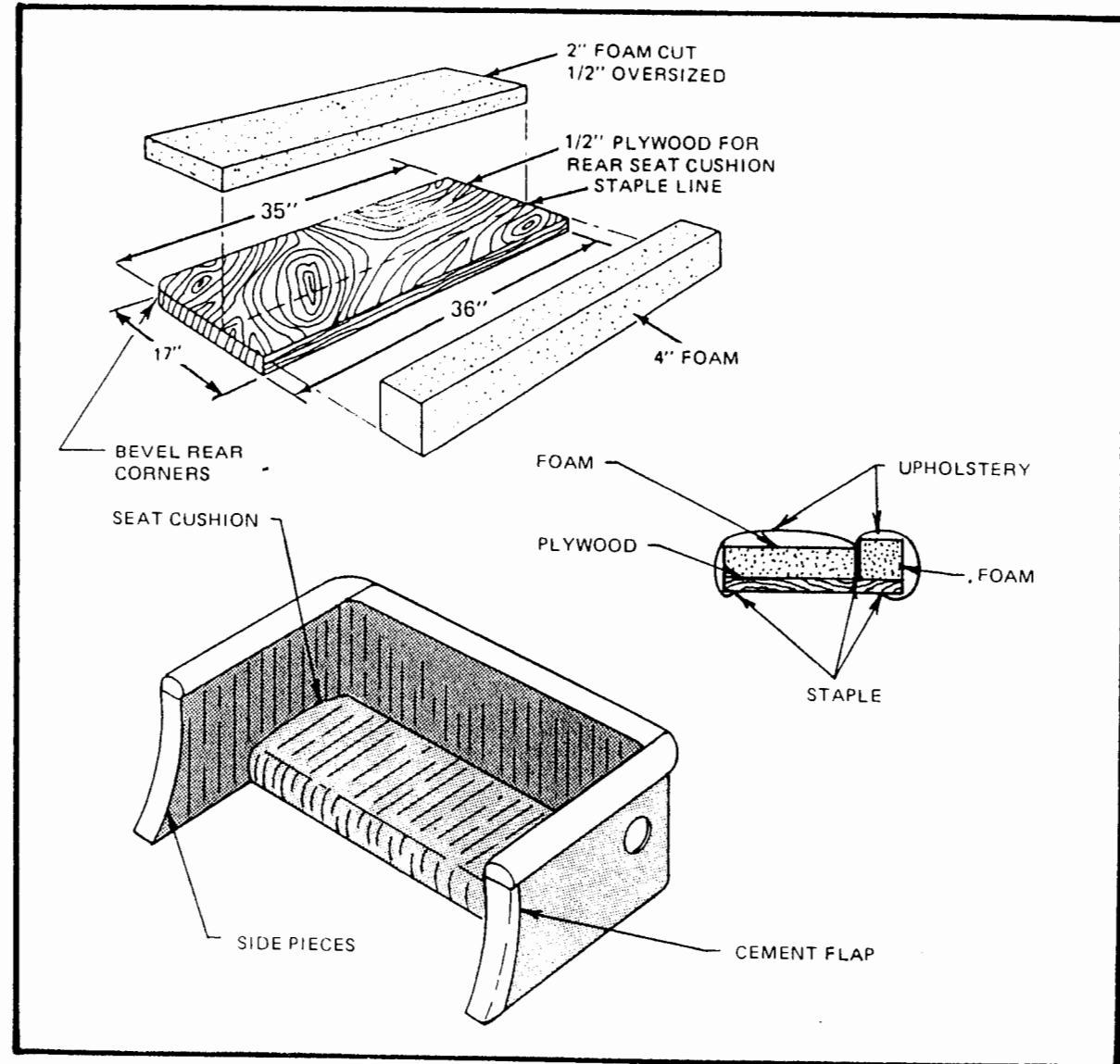

Figure 6

REAR DECK LID (Refer to Figure 7)

- Align hinges on edge of rear deck lid, approximately 8" from each side. Mark hole locations and drill 3/16" holes. Secure hinges using No. 10 x 1" stainless steel oval head machine screws with flat washer, lock washer and nut.
- Set deck lid on car and center from left to right. A slight over hang on each side is normal. Mark the location of the hinges on the rear seat liner.
- Drill out the hole in the short strap of the hinge to 1/4". Notch out the flange on the deck lid at each hinge. Drill a 5/16" hole into the flange of the seat liner at each hinge location and secure with 1/4 x 1" hex head machine screw with flat washer, lock washer and nut. If hole in hinge is lower than flange, fiberglass a piece of 2 x 2" fiberglass to the lip of the deck liner. Use a piece of material left over from the door cut outs.
- With leftover upholstery material, cover a 3/4 x 3/4 x 41 1/2" piece of hardwood. This will hold the coupe top studs. Place a bead of sealant between the piece of hardwood and the deck lid. Clamp strip to deck and drill 3/16" pilot holes from beneath deck lid. Attach with No. 10 x 3/4" round head wood screws.
- Center trunk hold down latches 9 1/2" in from rear sides of deck lid. Drill 3/16" holes and secure with No. 10 x 1" stainless steel phillips oval head machine screws. Cut studs flush with nuts.

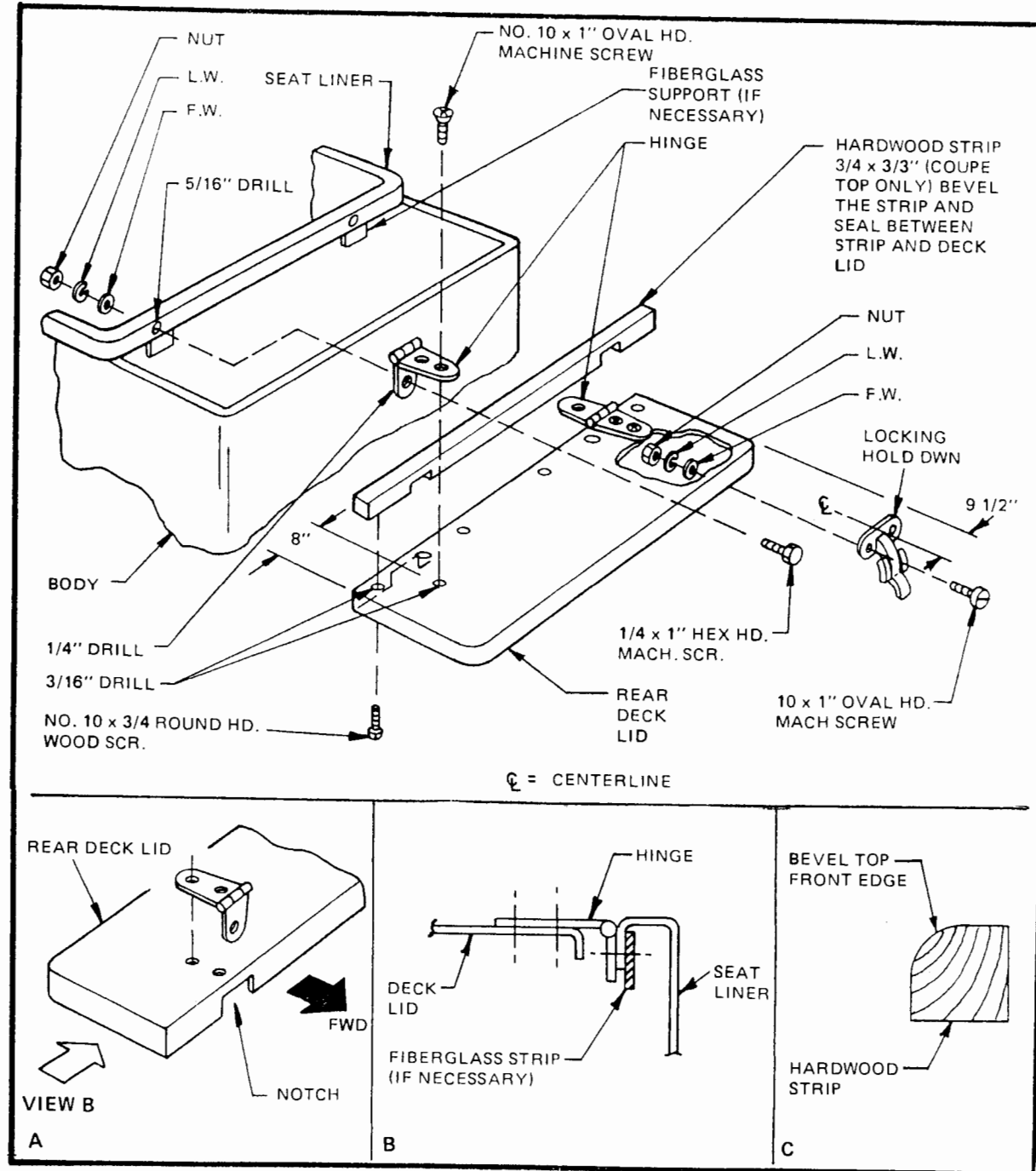

Figure 7

REAR DECK LID (Con't)

- If using the coupe option, for a finished look, 5/8" automotive trim strip matching the upholstery (available at auto supply stores), can be attached around the perimeter of the deck lid.

SEAT TRACK MODIFICATIONS

(Refer to Figure 8)

- Because of the configuration of the fiberglass seats the seat tracks must be modified before installation.
- From the center of the forward square hole, measure back 11" and mark slide. Drill a 5/16" hole at the marked location. (This is to compensate for the short base on the fiberglass seat.)
- Turn the slides over and cut off the mounting studs flush with the slide. Grind down the remaining base until the heads can be driven out with a center punch.
- On the free-moving slides (to be mounted on the outside edges of the seat) insert a 5/16 x 6" carriage bolt to replace the studs just removed. You will probably have to grind down one side of the head to allow it to fit. This new stud will pass through the 4" main frame member. On the locking slides (to be mounted on the inside edges of the seat) insert a 5/16 x 2" carriage bolt to replace the old stud. This will pass through the angle iron seat support on the frame.

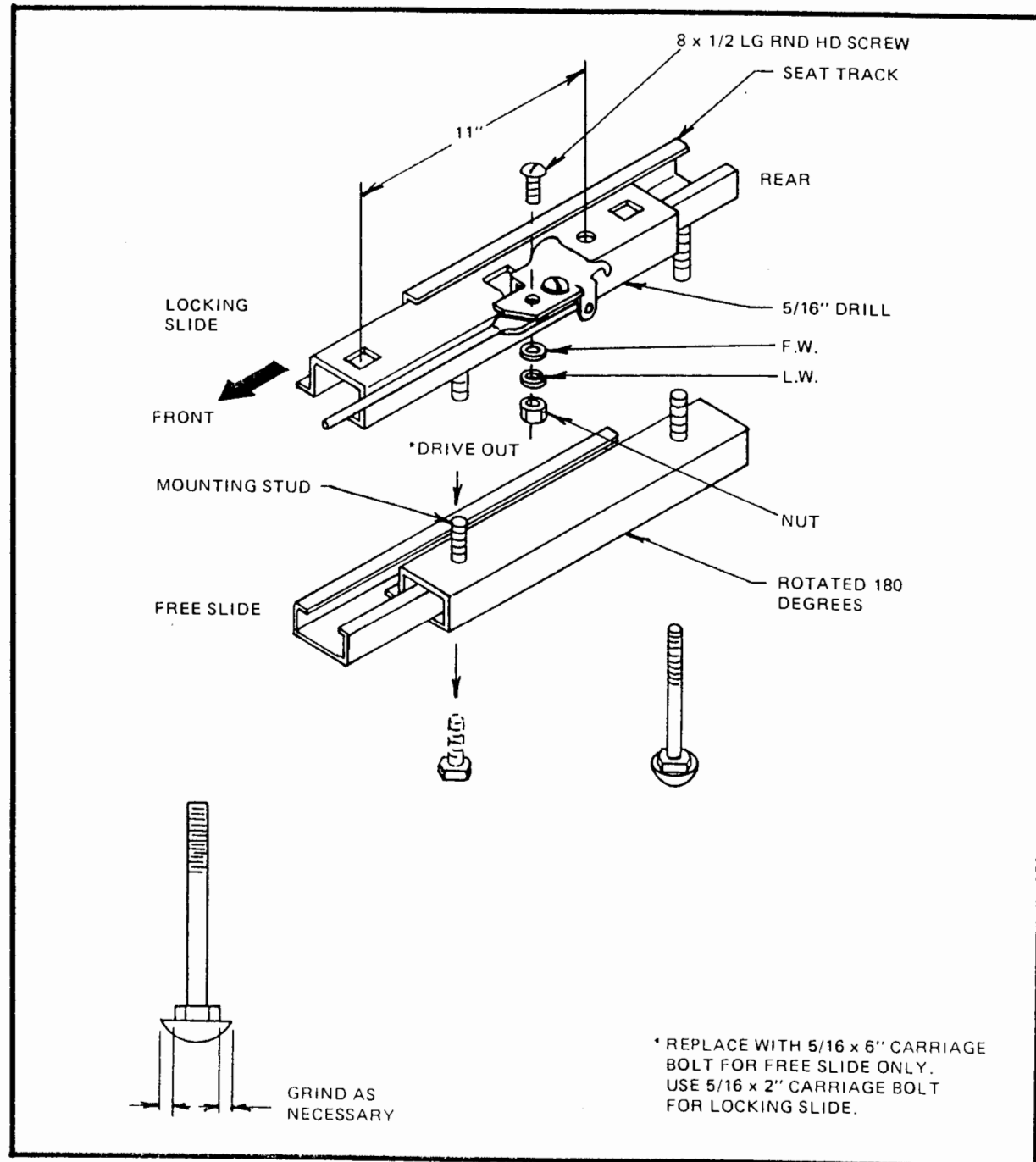

Figure 8

FRONT SEAT FABRICATION

- Grind and sand the edges of the fiberglass bucket seats all around until the edges are even and smooth.

CAUTION: Sharp edges may cut the upholstery fabric.

- Turn the bucket seats on their sides and mark the back side for cuts as shown in Figure 9.
- Drill 1/4" pilot holes, then with saber saw cut 1/8" wide slots to attach the upholstery to the seat base.
- Cut 1/2" plywood pieces so they fit inside the slots cut into the seats. The upholstery will be stapled to the plywood and it further supports the seat. Four small 1" wide strips are used as shown in Figure 9. Attach plywood to seat bottom by drilling 3/16" holes and securing with No. 10 3/4" round wood screws.
- Drill 5/16" holes for seat tracks 11 inches apart on 6" centers through the plywood on the bottom.

NOTE: Cup spacers are used between the seat tracks and seat bottom. This allows the slide lock to move freely. If you desire more of an angle, place 2 cup washers together with a washer in between. (Figure 9) This will give the seat a more comfortable angle and help the seat tracks clear the carpeting when installed.

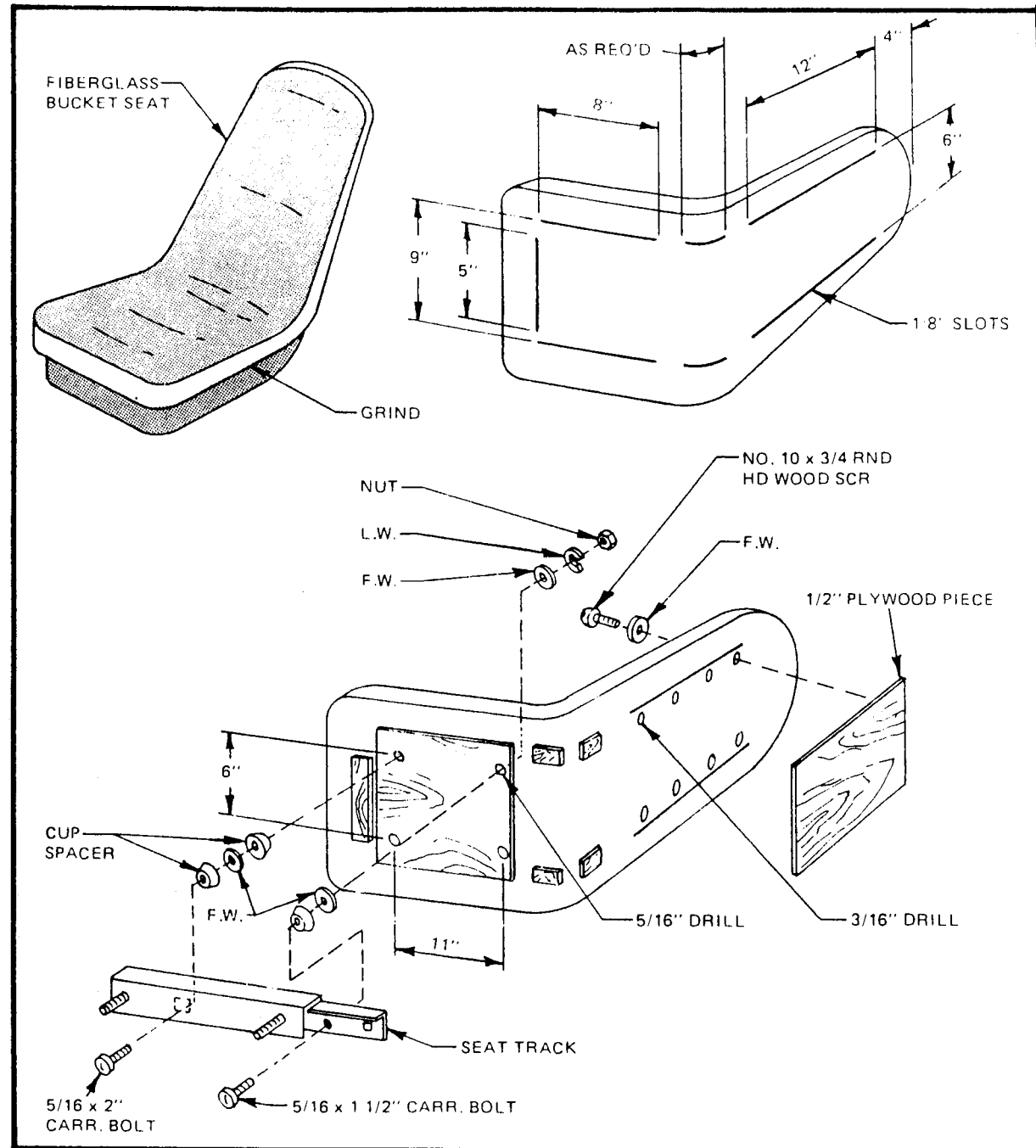

Figure 9

CAUTION: Be sure seat tracks are absolutely parallel to prevent binding after installation.

- Bolt rear of seat tracks to the seats using 5/16 x 1 1/2" carriage bolts with flat washer, lock washer and nut. Bolt front of tracks to seats with spacer in place using 5/16 x 2" carriage bolts with flat washer, lock washer and nut. Cut stud flush with nut.
- Spray the seat bottom with 3M "90" brand spray adhesive. Spray the matching area of the one-piece foam pad for the front seat.
- While the adhesive is still tacky, slip the bottom of the foam pad over the fiberglass seat and press into place.
- Using your fist, punch the center part of the foam pad sharply in the center to make sure the center part of the foam sticks to the bottom of the seat.
- Spray the seat back and the mating part of the foam with adhesive.
- Pull and stretch the foam over the back of the seat. (Figure 10)
- Press and punch in place to be sure the foam is well seated against the fiberglass.

NOTE: Additional foam can be used, if desired.

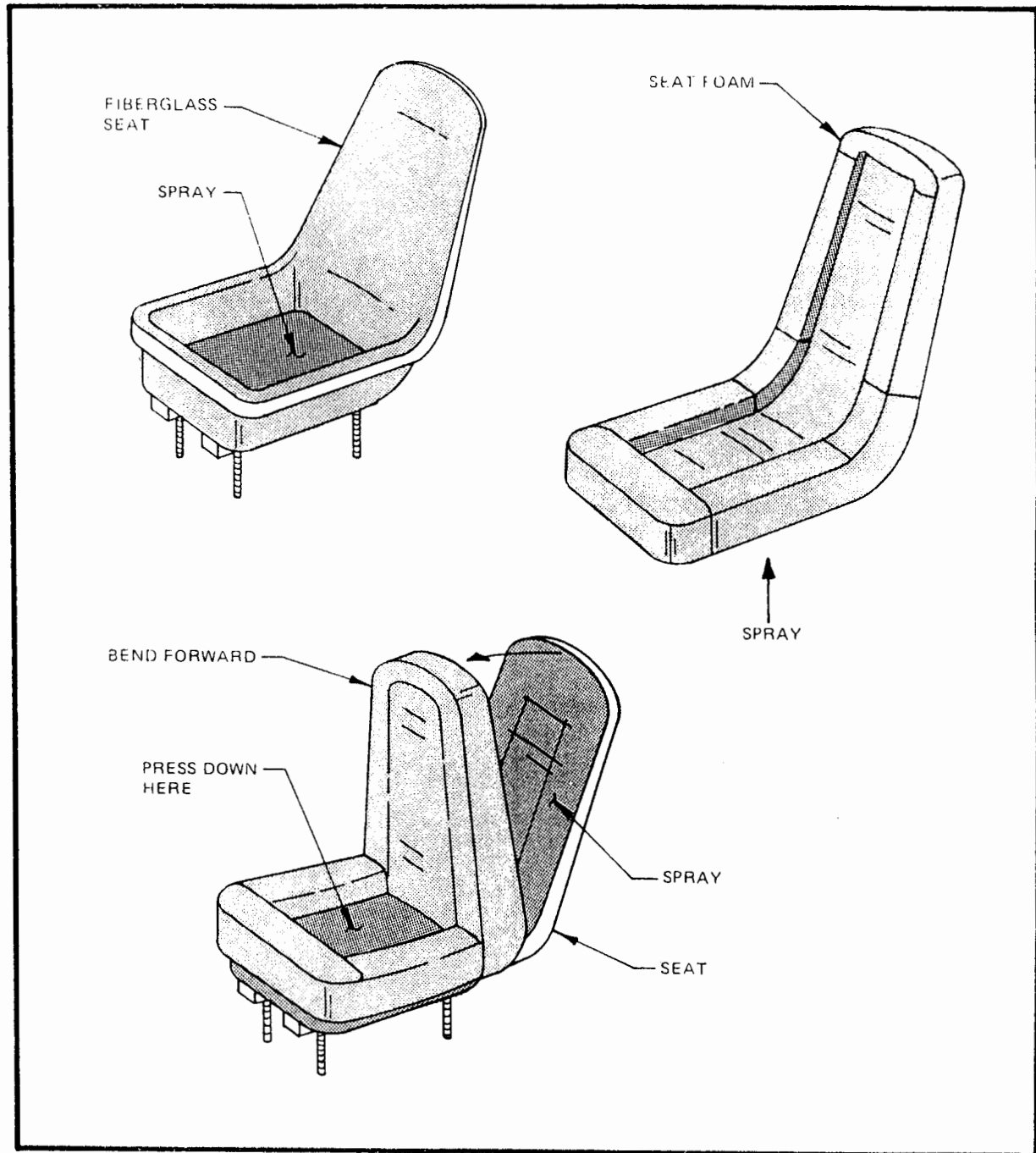

Figure 10

- Using a long sharp knife, cut through the foam along the slits previously cut in the fiberglass shell.
- If the attaching tabs on the seat back are not cut, do so now, cutting down the middle.
- Slip the seatcover upholstery over the top of the seat and work it down over the foam.

NOTE: This step is made easier if you cut a clear polyethelene bag (dry cleaning bag or kitchen bag) to fit over the top of the seat back. This will help slide the tight seatcover over the foam.

- As you work the seatcover down over foam, push the fabric tabs sewed to the back of the seatcover through the slots in the foam and the fiberglass. (It may be necessary to trim these tabs to size to pass through the slots.)
 - Pull the tabs all the way out through the slots. (Figure 11)
 - Once the seatcover is all the way on, pull the tabs up tight and check the fit of the upholstery. When you have the best fit, staple the tabs to the wood strips.
- NOTE:** This step usually requires two people, since you will need to pull hard and hold the tabs while stapling.
- Finish off the seat bottom by folding the tabs over and stapling the excess to the wood strips.

- Stretch the outer edge of the seatcover around the edge of the fiberglass frame and glue securely to the fiberglass.
- For a neat appearance, mask off the upholstery that will be visible when the

seat is installed and spray the underside of the seat with flat black paint. (Figure 11)

- Glue a piece of carpet to the lower back of the seat to cover the fiberglass.

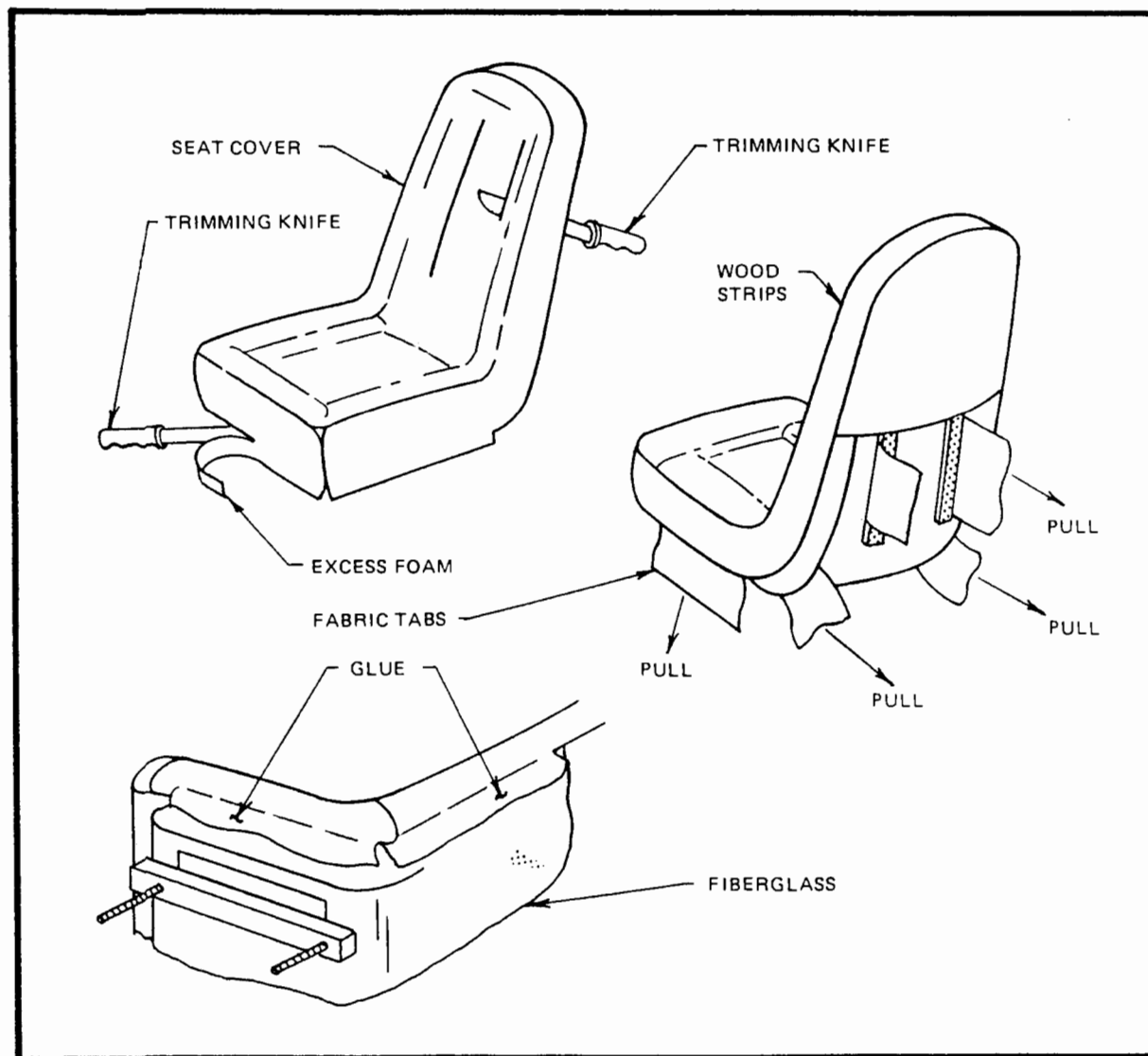

Figure 11

STEERING WHEEL (OPTIONAL)

HORNBUTTON MODIFICATION

- If using our optional steering wheel, the horn button mechanism will have to be modified as follows:
- Remove center nut of Chevette steering wheel and remove from shaft. You can hit the wheel from behind or use a wheel puller. Do not strike center shaft.
- Remove aluminum pin, plastic retainer and spring from column. Discard aluminum pin if it is not used with optional wheel. Cut female spade terminal off wire that is included in hub kit. Place wire with contact end into hole in Chevette column. Slip spring and retainer over wire and lock in place. Attach female spade terminal to end of wire.
- Install steering wheel adapter onto column. Attach wheel to adapter. Hook up wire to horn button and snap into position. Torque adapter to column using 20 ft. lb.

SEAT BELTS

- While the stock Chevette seat belts can be used, if the brackets are strengthened, we use smaller belts on the assembly. Available from our factory, these belts are installed with the seats. The car seat studs pass through holes in the brackets at the end of the belts. (Figure 13)

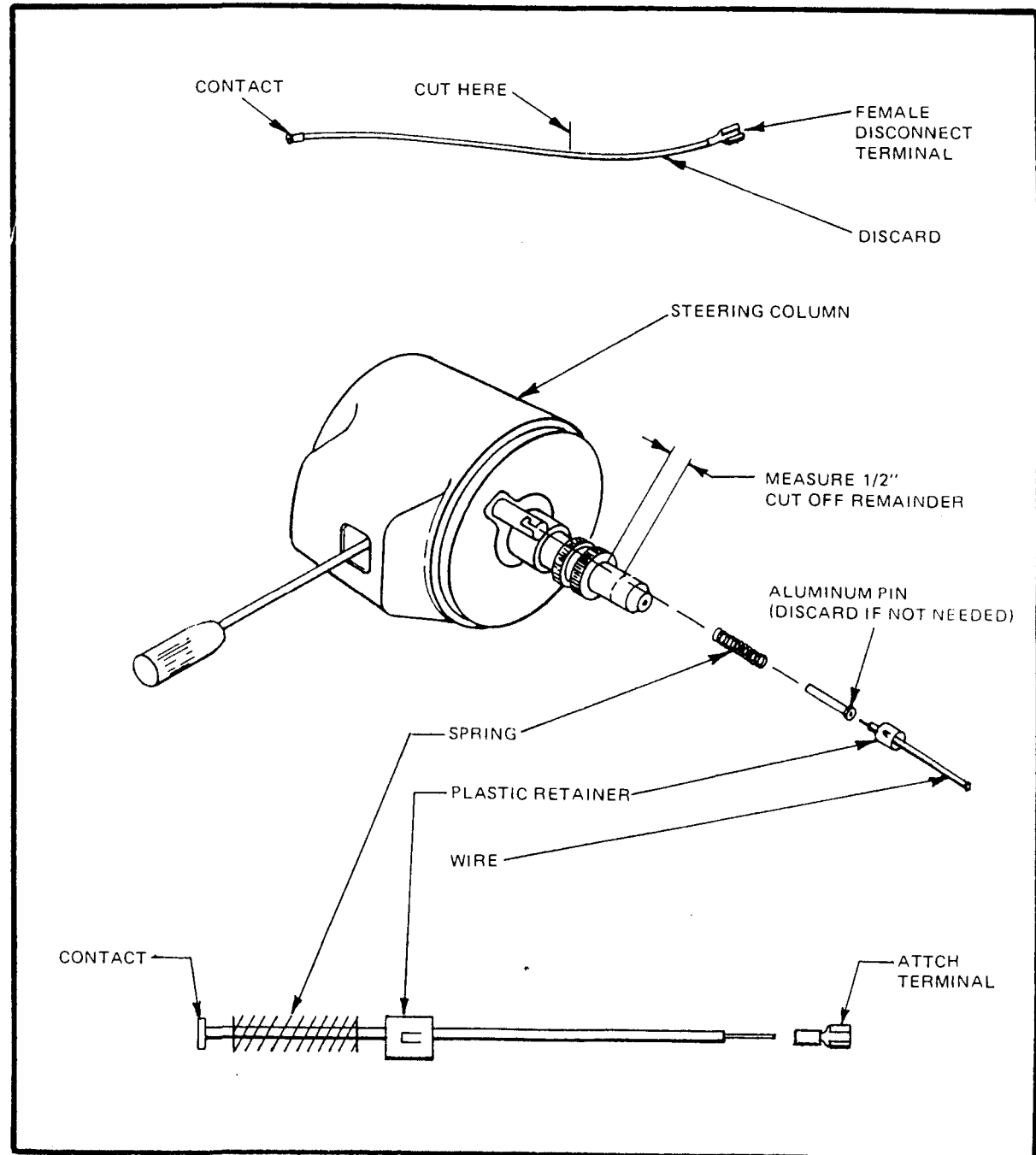

SEAT INSTALLATION (Refer to Figure 13)

- Position seat tracks in the center of adjustment so that they can be adjusted the same amount forward or backward.

NOTE: The following positioning of seats gives the proper location for the average person. The location can be moved forward or backward as desired to fit your individual requirements.

- Locate the seat as shown in Figure 13.
- Measure and align the four holes and mark for drilling.
- Drill 4, 3/8" holes with a long drill bit. The two outside holes should pass through the center of the main frame members. The two inside holes should pass through the angle iron seat support of the frame.
- Put the seat in position, and push the studs down through the holes.
- Sit in the seat to check the position.
- Bolt the seats securely in place. Use washers placed on inner studs which pass through fiberglass.

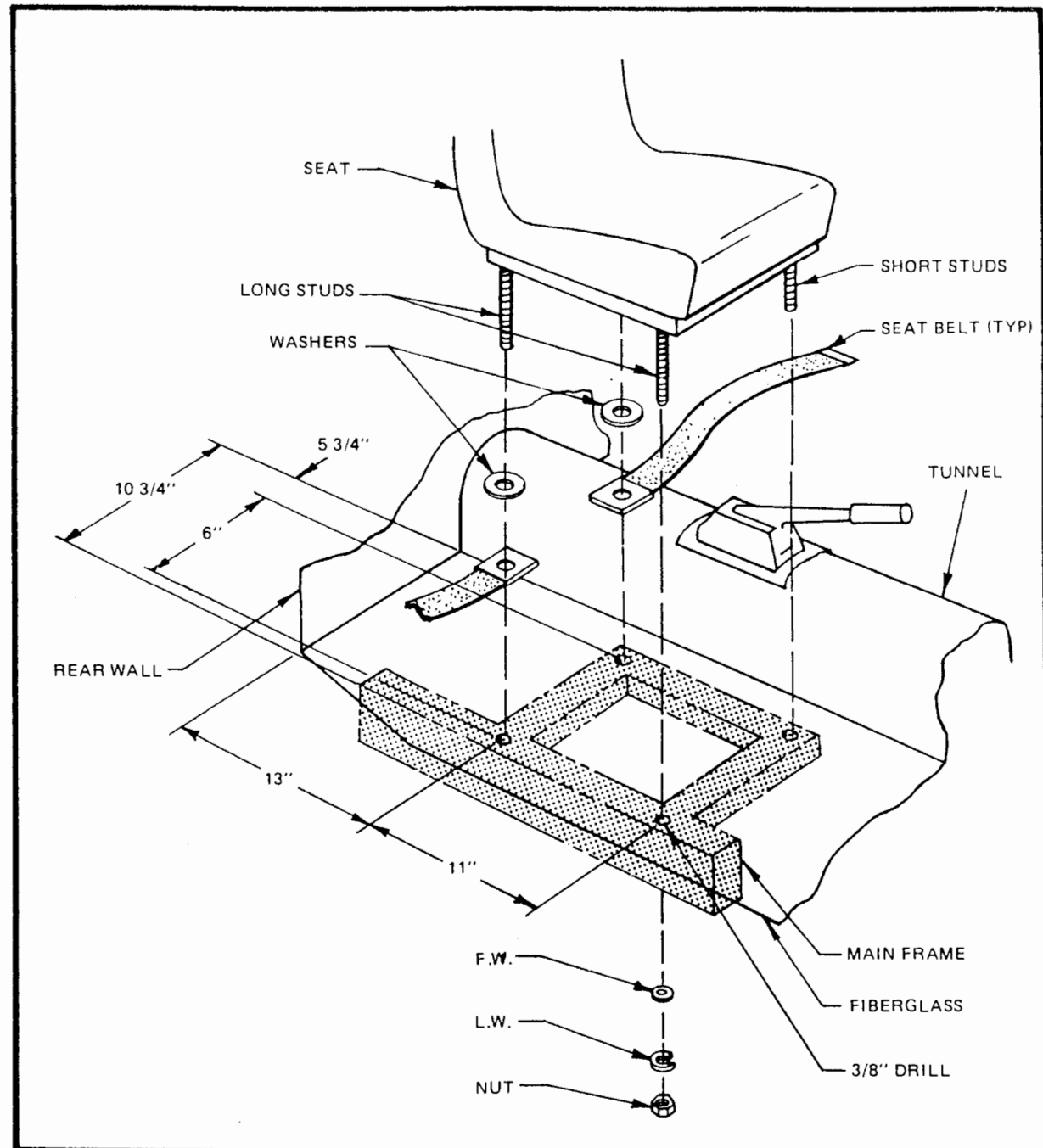

Figure 13

PADDED ROLL

The padded roll consists of 1 fiberglass dashboard channel, 2 door channels and 2 door post angles. These are covered in foam padding and upholstery and secured to the car using the convertible top snap studs packed with the top.

- Trim all rough fiberglass edges. Round off all corners.
- For the dashboard section, glue the half round black foam to the top of the channel with 3M "90" spray adhesive or equivalent. Glue the pre-cut 1" foam over the top of that and down on each side. With a scissor, taper the foam edges where it meets the fiberglass.
- On door sections, cut a strip of 1" thick piece of foam the width of the fiberglass channel and glue in place. Glue an additional piece of 1" foam on top of that and down each side. Taper the edges into the fiberglass.
- For door posts, glue a strip of 1" thick foam on the front of the angle. Glue an additional piece over that and down the side. Taper the edges into the fiberglass.
- Spray glue onto the foam and stretch the upholstery fabric over the channel. Bring it underneath and glue to the underside of the channel. Trim upholstery as necessary to avoid bunching up under the channel.

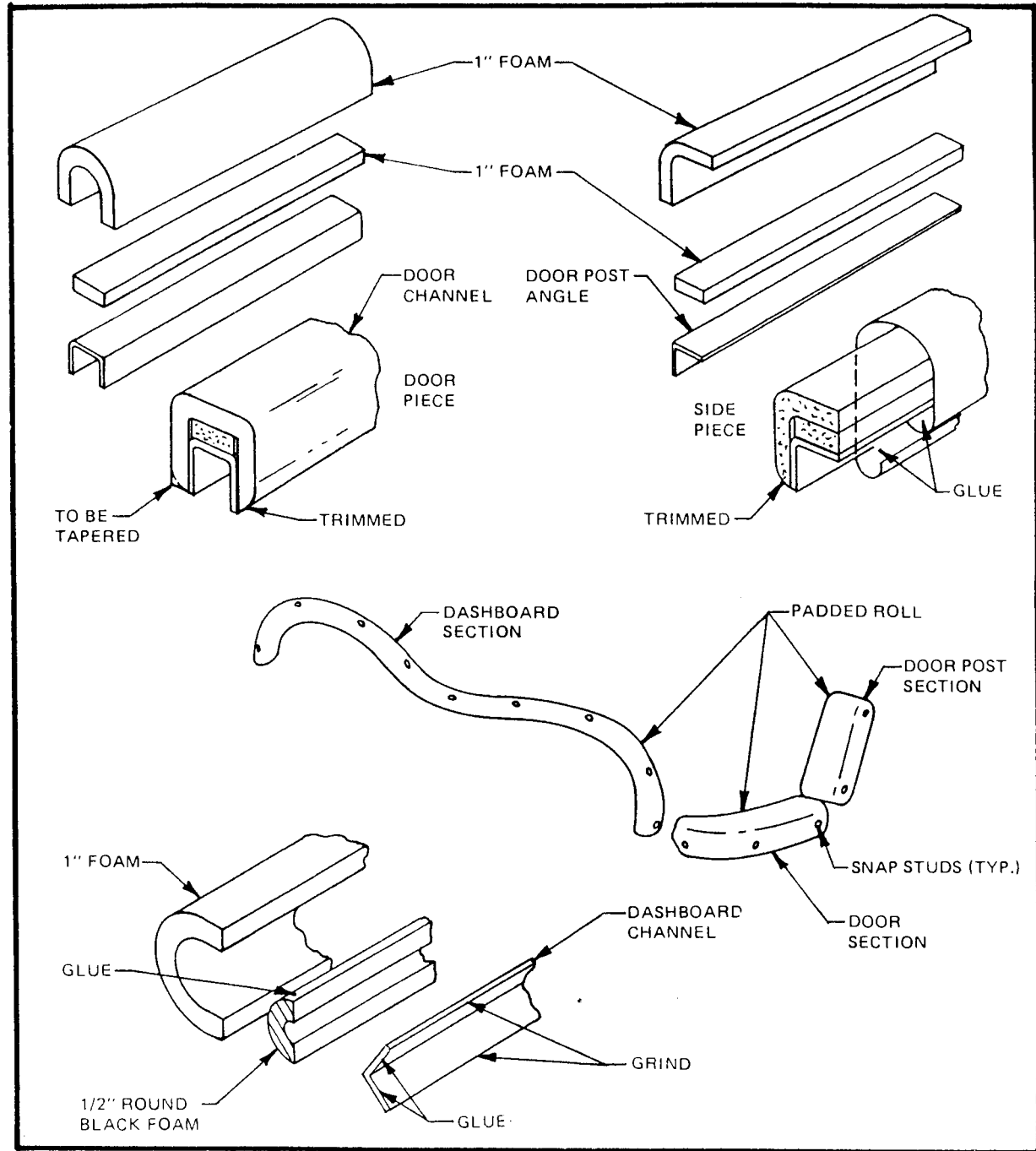

Figure 14

PADDED ROLL (Con't)

- On the dash board section, drive one stud into the center top of the padded roll and one on each end. Secure with an additional 6 studs, evenly spaced. (These are to hold the tonneau cover to the dash. In the event the tonneau cover is not used the snap studs are still the best way to secure the padded roll.)
- Fit each section in place and attach with snap studs. Use 3 on each door section and 2 on each door post section.

ANTENNA (OPTIONAL)

- The antenna available from the factory mounts on the passenger side as shown in Figure 15. If using another antenna, mount in a similar fashion.
- The antenna is secured through the body with 2 No. 8 oval head stainless steel machine screws. The shaft of the antenna is parallel with the windshield.

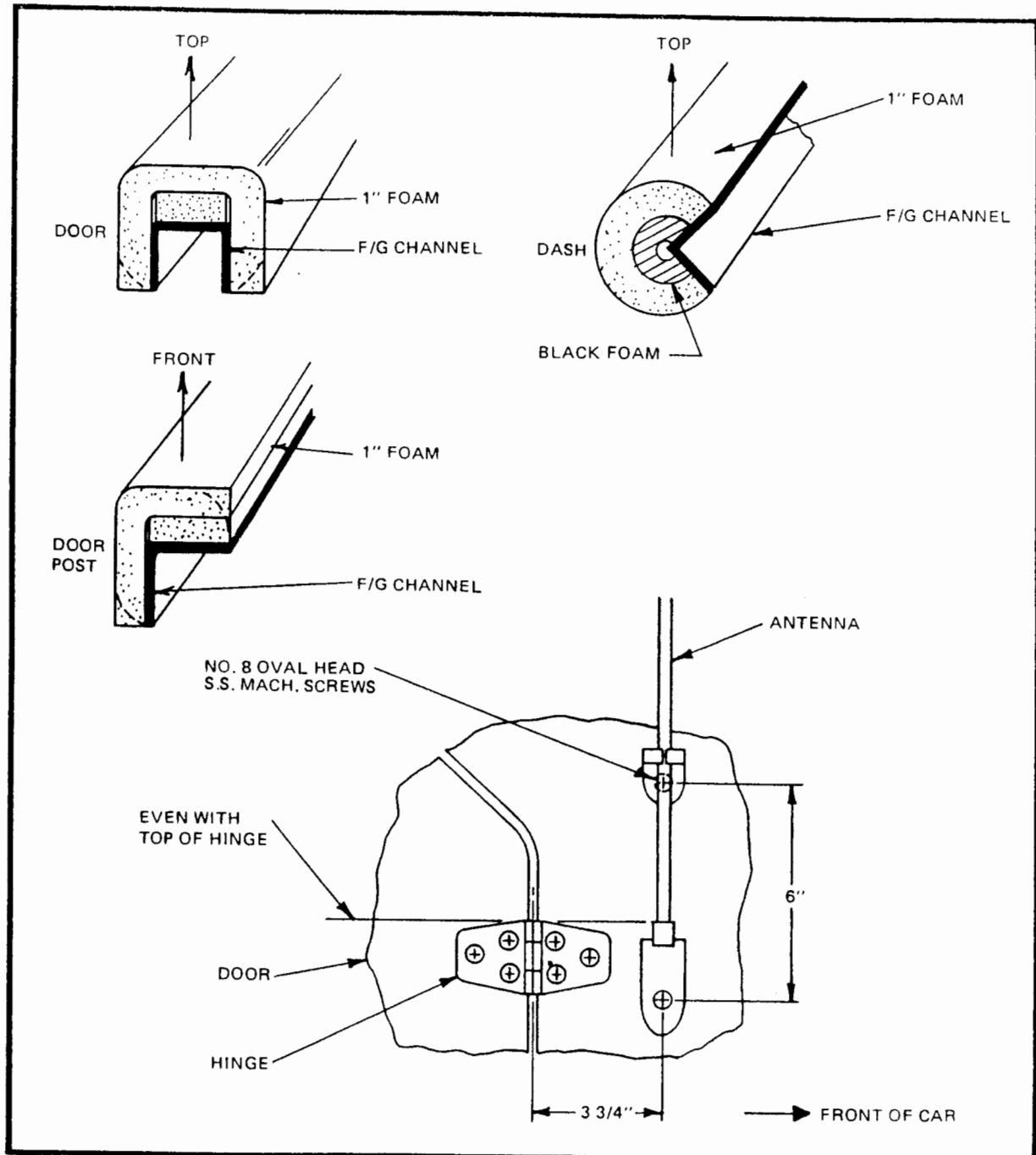

Figure 15

WINDSHIELD (Refer to Figure 16)

- Position the windshield along the supporting ridge of the fiberglass body.
- Attach brackets, using cap nuts and knurled knobs. Shorten studs, if necessary.
- Mark the position of the windshield and the upper mounting hole. Remove the windshield.
- Apply a strip of adhesive foam gasketing or windshield sealant strip along the fiberglass body under the windshield.
- Position the windshield on the gasketing and press down to insure a good seal.
- Carefully drill $5/16''$ holes through the upper mounting holes and attach the support bracket with $5/16 \times 1 \ 1/4''$ chrome carriage bolts with flat washer, lock washer and nut.
- Leave the lower bolts free until you install the top.
- It is recommended that a $1/4''$ thick plywood backing plate (as shown in illustration) be used.

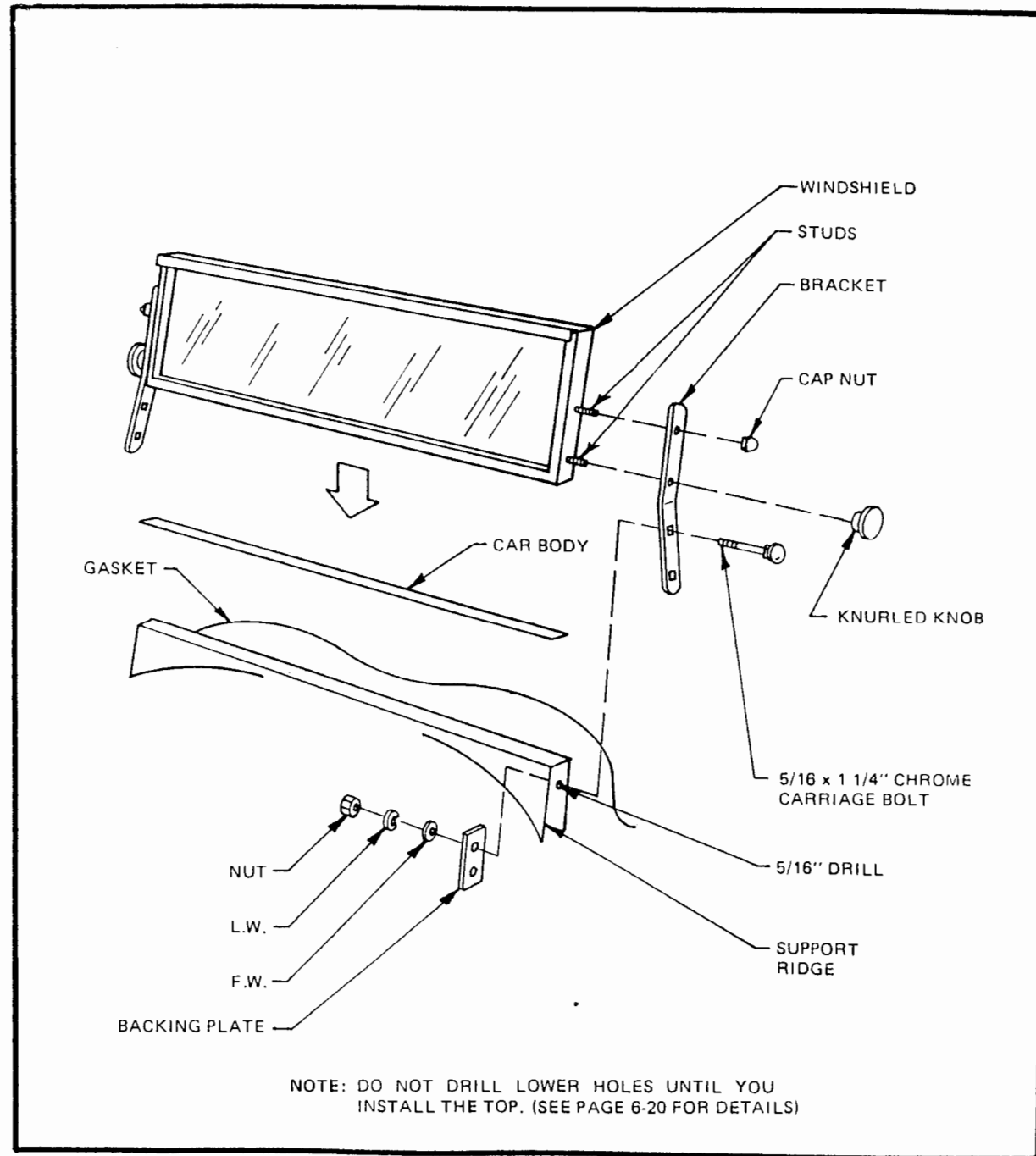

Figure 16

WIND WINGS (OPTIONAL)

- The wind wings mount to the flange on the side of the windshield. Refer to Figure 17. It may be necessary to modify the hinges so there is sufficient tension to prevent wind wing from flapping.
- Using a punch, drive out the pin holding the hinge together. (One end of the pin will have 3 indentations in it. Drive the pin out by punching from the opposite smooth side.) Refer to Figure 17
- When the pin is removed drill the holes to $9/64$ ". Install No. 6 x $1\ 3/4$ " round head machine screws and lock nuts. Attach hinges to wind wing as shown.
- Measure down $1\ 1/2$ " from the top of the flange and mark with a grease pencil. Align wind wings on flange with the top of the upper hinge on the mark and the squared edge flush with the back edge of the flange. Mark hole locations. Drill $1/8$ " holes at the marked location and secure with No. 8 x $3/8$ " stainless steel oval head machine screws with cap nuts.

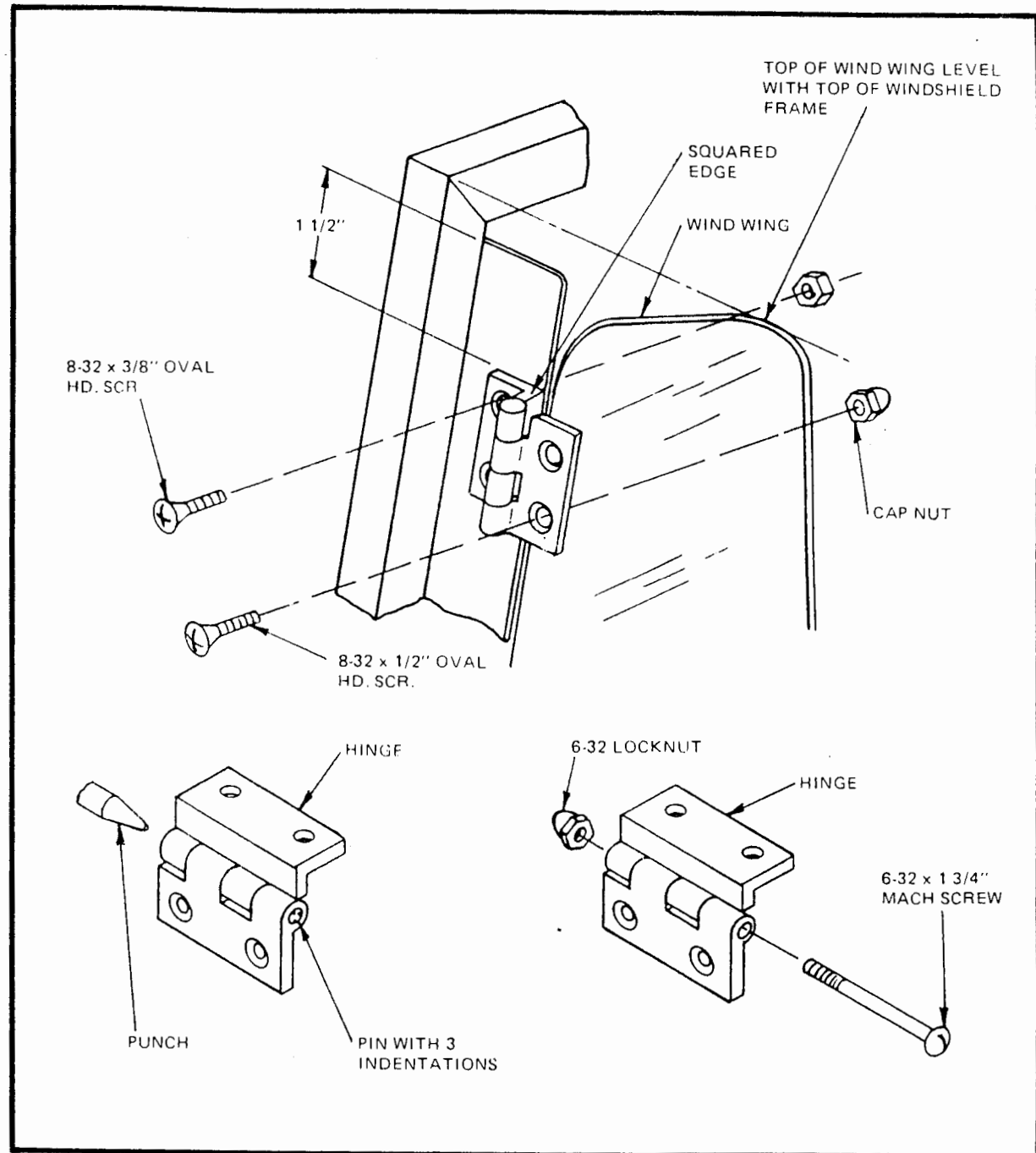

Figure 17

DOOR TRIM STRIPS

- Narrow strips of material are furnished with the upholstery kit to trim the door lip cut out and provide a finished appearance to the interior.
- After the carpet has been installed cut the strips to fit over the door lip as per illustration. Allow the material to extend 1" over the carpet and to the door sill of the body.
- Use 3M spray 90 or equivalent and glue in place.
- If desired a door strap can be made from flat web material similar to what is used for seat belts. This will prevent the door from opening too far and possibly scratching the fenders.
- Use upholstery trim screws and secure the door straps to the plywood hinge support plates in the door and in the body forward of the door.

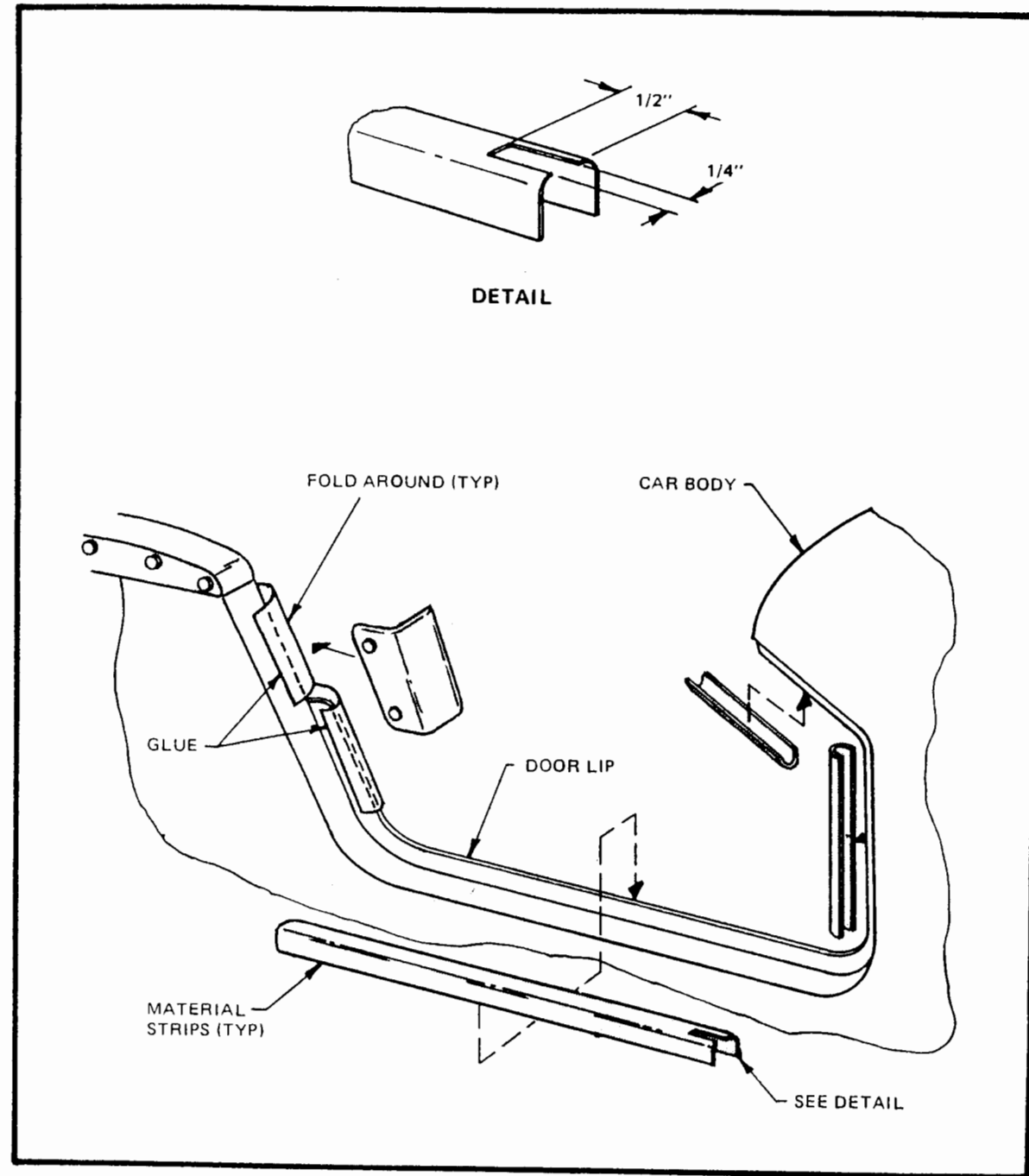

Figure 18

CONVERTIBLE TOP

The convertible top utilizes a number of different fasteners to attach the various components together. Basically there are 3 separate items. (See Fig. 21, pg. VII-21)

Male snap stud for fiberglass or wood.

Male snap for fabric.

Female snap for fabric.

Snaps that install in fabric must be installed using a special tool that crimps them in place. These can be rented for a day at a time in most locations. There are also sets of dies available that slip on to any standard vise-grip plier, turning them into an installation tool.

- When locating a snap position, pull the material over the stud and feel for the stud through the material. Mark the spot with a grease pencil and install a snap.

STANDARD TOP

- Remove bows from their sockets and measure from end to end. The large bow (rear) should measure 84" and the small bow (front) 74". Cut as necessary, keeping the side legs even.
- Measure back approximately 13 1/2" from the front of the rear seat liner and mark. Align the bow mounting foot on the mark and fasten with No. 10 x 1" oval head self-tapping screws. Do not

over tighten as the thread will strip out of the fiberglass. (The exact location of the mounting foot may vary slightly depending on how the seat liner was installed.)

- Slide the bows through the pockets in the top and reattach to the sockets.

- Pull the top forward, toward the windshield. Insert a 1/8 x 1" x 36" long aluminum or wood strip into the pocket sewn on the front of the top. Insert the pocket into the channel formed at the top of the windshield. This forms a water tight seal between top and windshield.

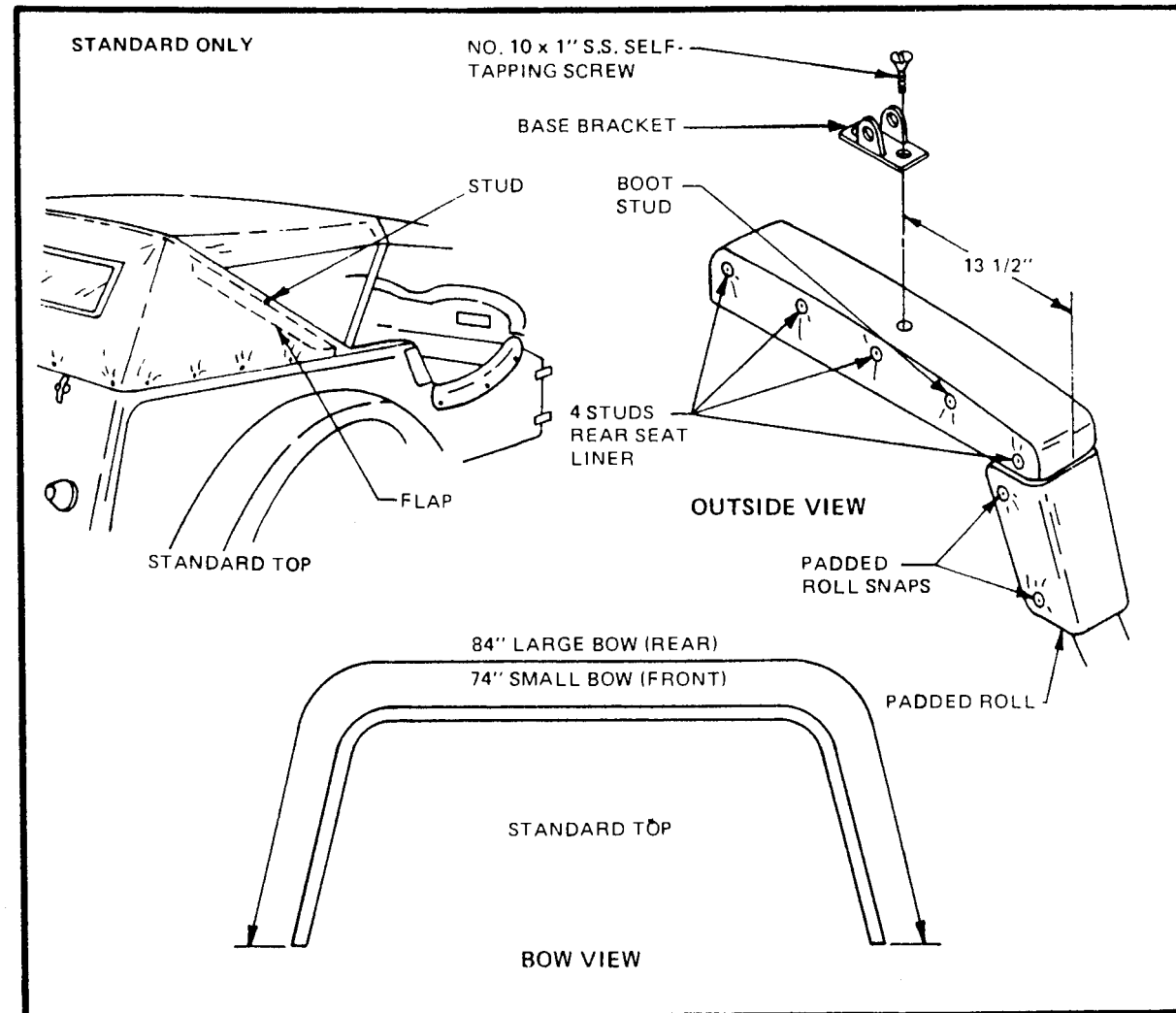

Figure 19

- Insert 1 snap stud into the rear center of the deck lid. Install a matching snap onto the top using a snap installation tool. **NOTE:** It is best to use a male snap without stud and pop rivet in place. This will insure that the trunk lid closes properly. If you use studs, trim flush.

- Stretch the top across the back and install a stud and matching snap at each end of the deck lid. Install two more studs and snaps halfway between the end studs and center stud.

- Tilt the windshield forward to remove all wrinkles from the top. Keep the top taut and mark through the lower holes in the windshield brackets. Drill 5/16" holes and secure with 5/16 x 1 1/2" chrome carriage bolt with flat washer, lock washer and nut.

- Pull the sides of the top forward along the sides of the rear seat liner.

- Install 2 snap studs and snaps on each side of the deck lid and 4 studs and snaps into each side of the rear seat liner. Install an additional stud and snap at each corner of the rear deck lid.

- At the windshield, pull the sides of the top taut and install a snap stud in the windshield frame and a matching snap in the top. (Use care when installing the stud in the windshield frame. Replacing the screw in the stud with a pop rivet works well here.)

- On the inside of the top wrap the flap around the main bow and install a snap and stud.

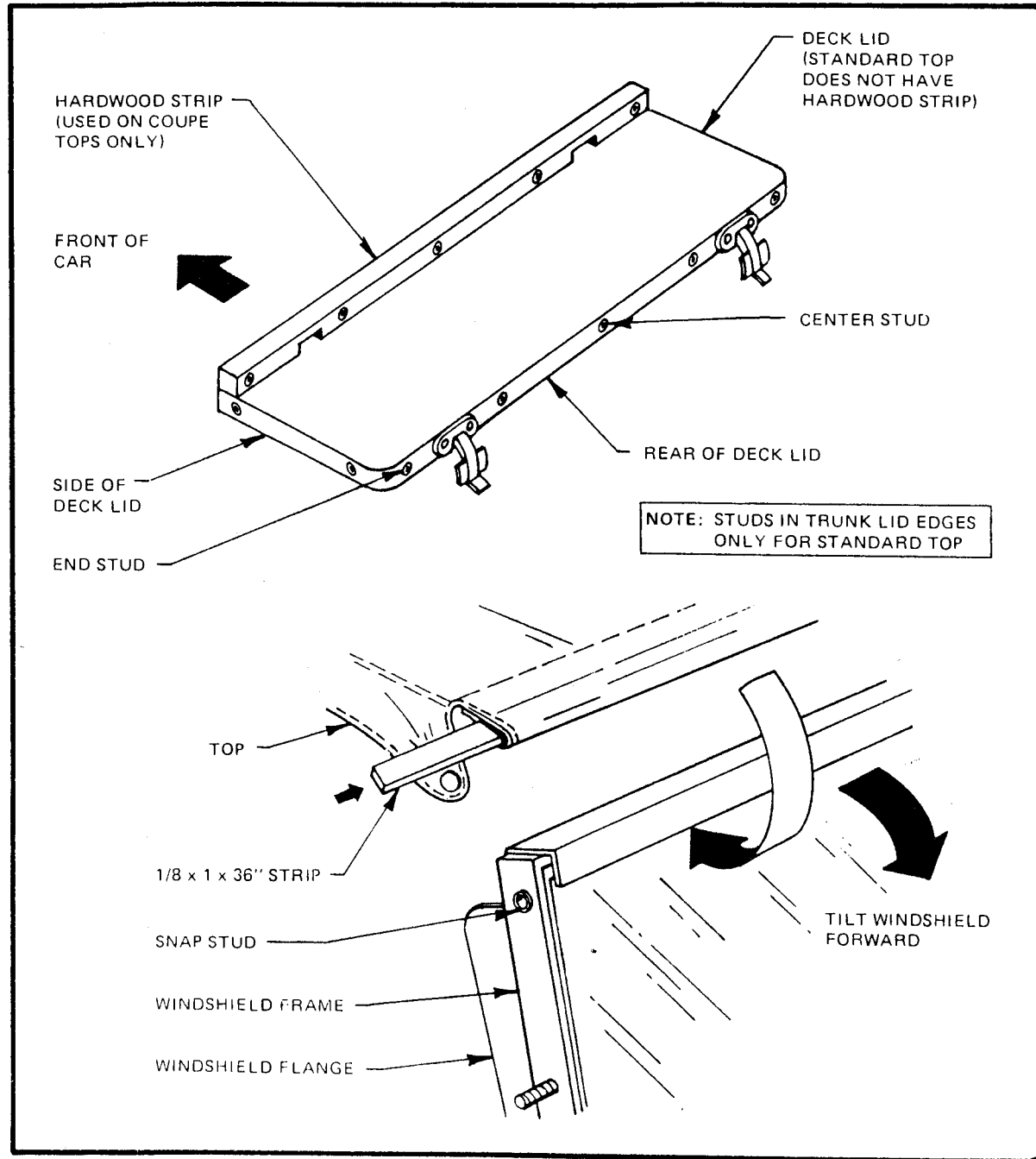

Figure 20

COUPE TOP (OPTIONAL)

- Remove bows from their sockets and measure from end to end. The large bow (rear) should measure 79" and the small bow (front) 74". Cut as necessary, keeping the side legs even.
- Measure back approximately 4" from the front of the rear seat liner and mark. Align the bow mounting foot on the mark and fasten with No. 8 x 2" oval head self-tapping screws. Do not over tighten as the thread will strip out of the fiberglass. (The exact location of the mounting foot may vary slightly, depending on how the seat liner was installed.)
- Slide the bows through the pockets in the top and reattach to the sockets.
- Pull the top forward toward the windshield. Insert a 1/8 x 1" x 36" long aluminum or wood strip into the pocket sewn on the front of the top. Insert the pocket into the channel formed at the top of the windshield. This forms a water tight seal between top and windshield.
- All other steps are identical to standard top except the rear studs are installed in the hardwood strip instead of the deck lid and 4 snap studs and snaps are installed on the sides of the seat liner.
- Install a snap stud on the body in the area between the windshield bracket and padded roll with a matching snap on the side curtain. This will prevent water from blowing up into the car.

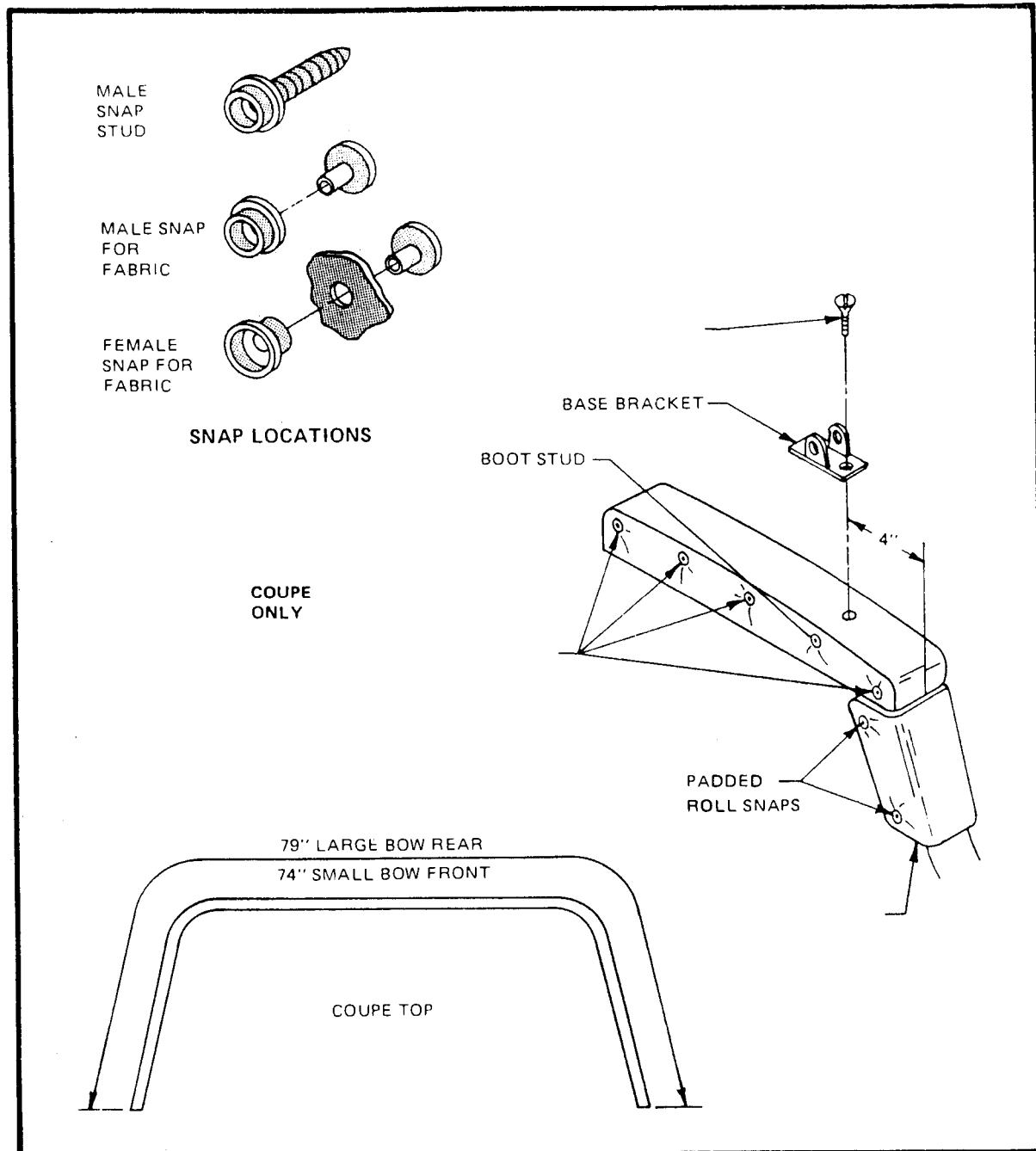

Figure 21

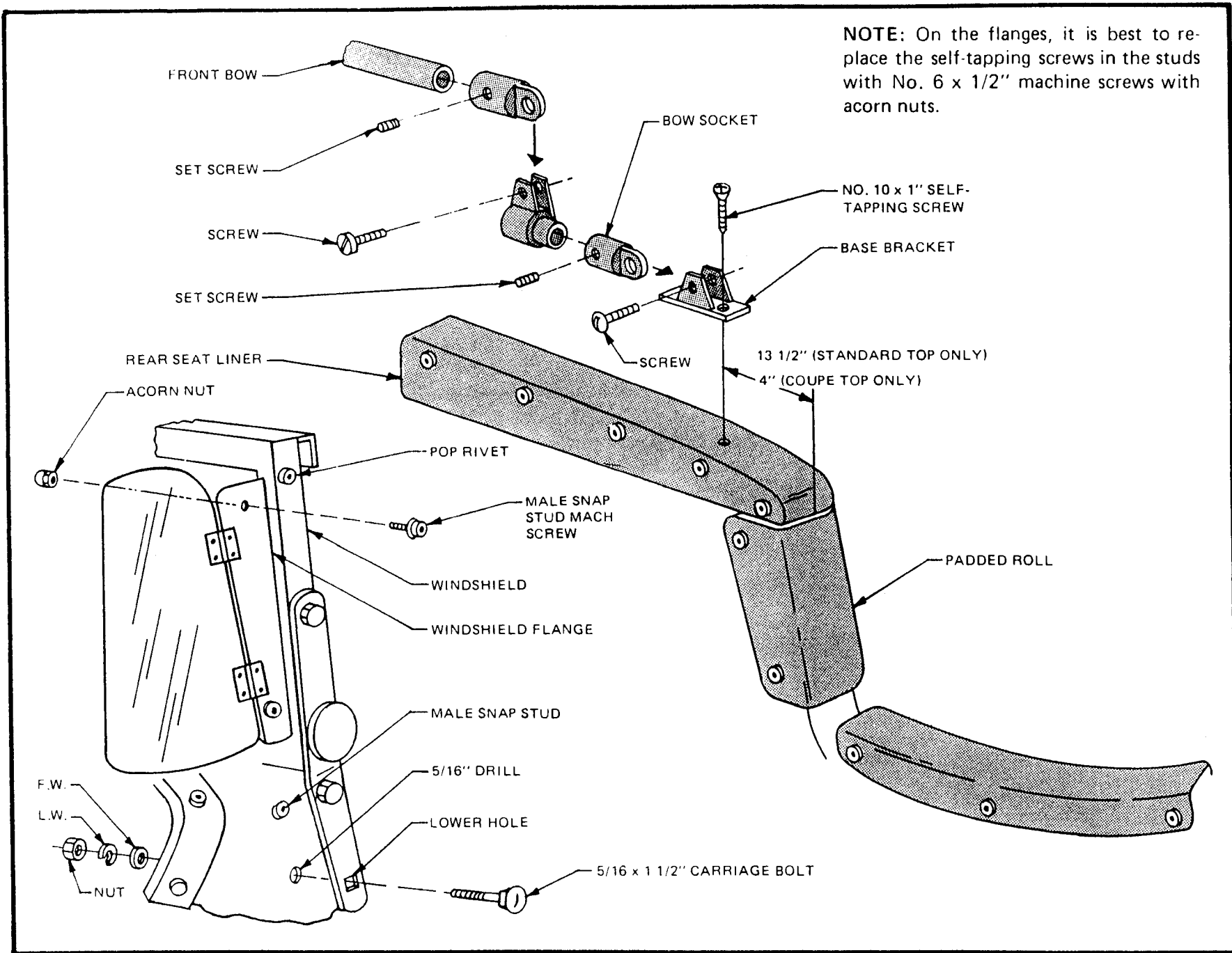

Figure 22

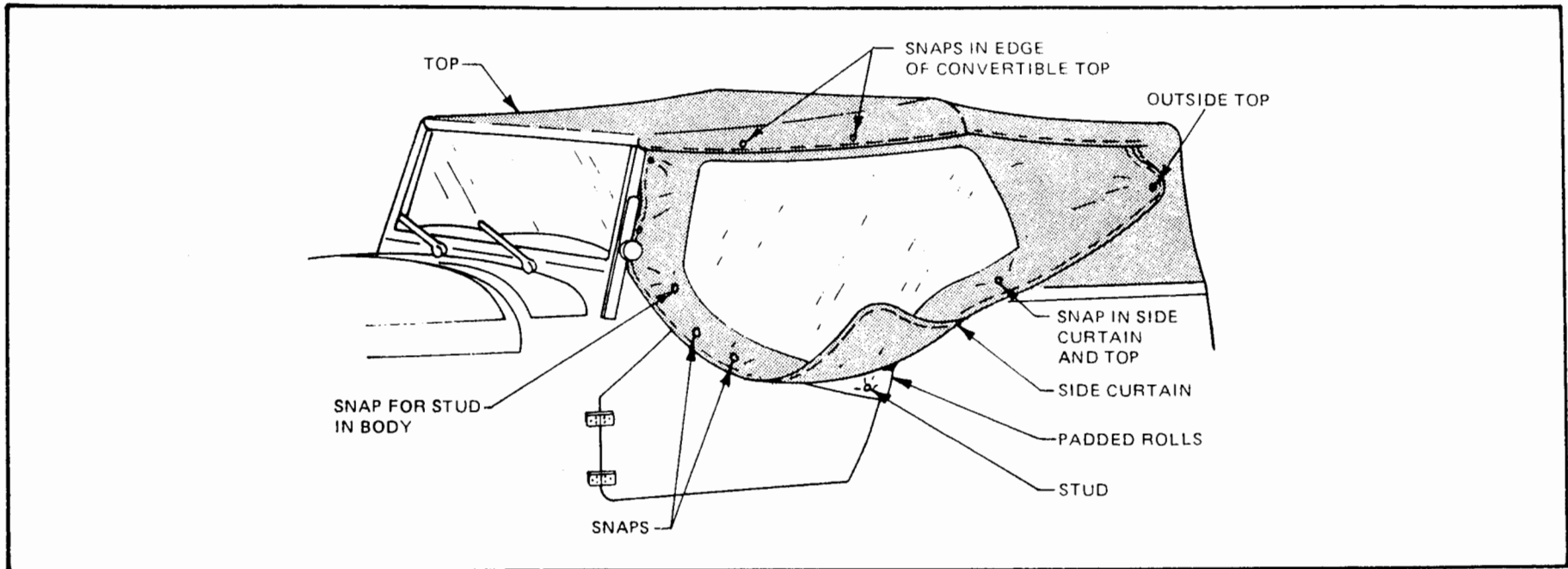

Figure 23

SIDE CURTAINS

- Align the side curtains with the flange on the windshield frame. Install snap studs in the side curtain to match the snaps in the top edge of the convertible top.
- Allow the side curtains to hang down over the doors. Install a snap at each point where the side curtains meet a snap stud.
- At the rear of the side curtain, where it is notched, bring the lower part of the

side curtain outside the top and install a snap and stud.

- At the lower rear corner of the side curtain install a snap stud to the lower edge of the convertible top and a matching snap in the side curtain.
- Install snap studs 1" from the upper and lower edges of the windshield flange and matching snaps in the side curtain.

NOTE: On the flanges, it is best to replace the self-tapping screws in the studs with No. 6 x 1/2" machine screws with acorn nuts.

- Install a snap stud on the body in the area between the windshield bracket and padded roll with a matching snap on the side curtain. This will prevent water from blowing up into the car.

BOOT COVER

- After installing the top and side curtains, remove side curtains and fold the top back along the rear of the body.
- Unsnap the top from the snaps at the rear of the car.
- Lay the boot cover over the top and attach snaps to match the studs and the rear deck lid. Attach snaps in a similar fashion around the outer edge of the boot cover.
- Stretch boot cover over the top and attach studs to the inside of the seat. Put the matching snaps in the boot cover. These snaps are at the front and rear of the inside side flaps.

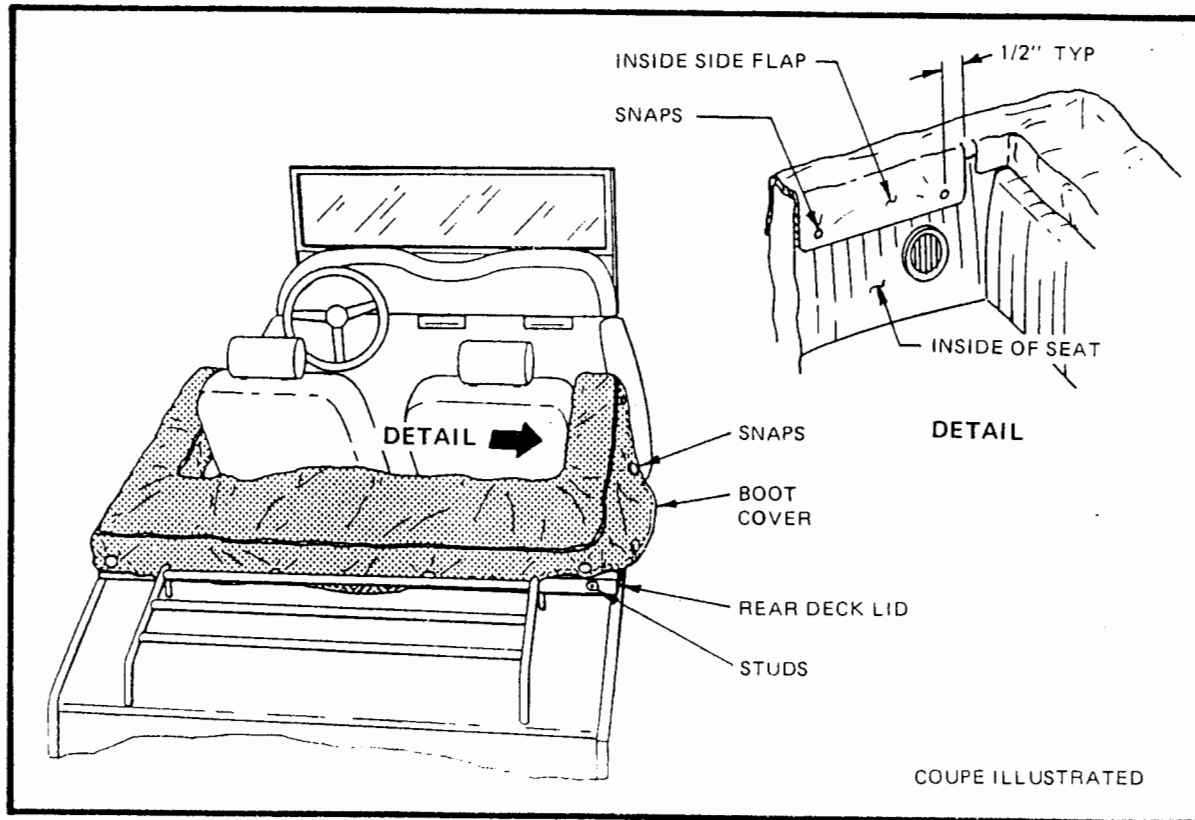

Figure 24

LUGGAGE RACK (COUPE TOP)

- Center luggage rack on the rear deck 1" from rear edge. Mark hole locations and drill 1/4" holes. Secure to rear deck with four 1/4 x 1" cap screws, with flat washers and lock washers. **NOTE:** Rubber spacers available from the plumbing department (faucet washers) of your local hardware store should be used between the luggage rack and deck.

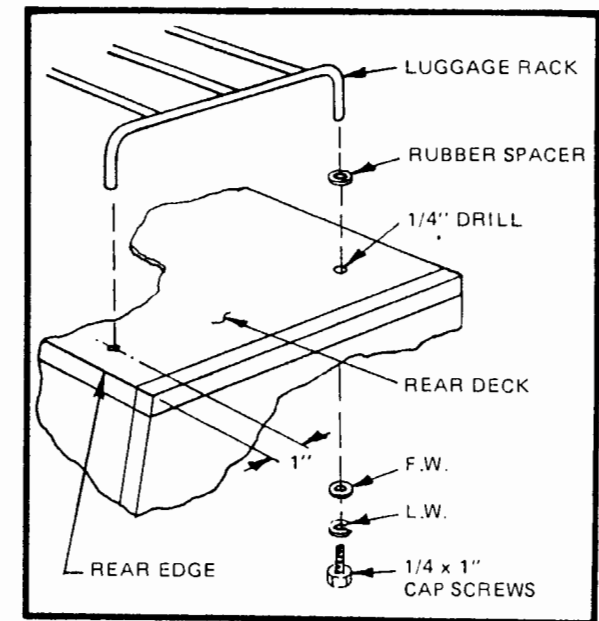

Figure 25

MIRRORS (Figure 26)

- REAR VIEW:** The stock Chevette rear view mirror is ideal for use on the assembly. Obtain a new mounting tab from a local GM parts dept. Mount the metal tab to the windshield using a special two-part adhesive available at auto supply stores. Follow the manufacturer's instructions for use of the adhesive. The center of the metal mounting tab (Fig. 27) is located 3" down from the top center of windshield frame.
- SIDE VIEW:** While the Chevette side view mirror can be used you may prefer to use a substitute mirror similar to the optional mirror(s) available from the factory. This mirror can be used on both the driver and passenger sides of the car, if desired.
- To mount optional mirror place gasket on body parallel with the top of the door opening between the windshield support and the dash padded roll. Adjust so front hole in gasket is located 2 1/2" above top of door opening. Rear hole is 3" above. Have someone hold mirror(s) in position and adjust for proper driver vision and door clearance. Mark final hole locations. Check for obstructions behind hole locations and carefully drill 2 1/8" holes through body. Mount mirror to body using 2 No. 8 x 1" stainless steel machine screws, flat washers, lock washers and nuts.

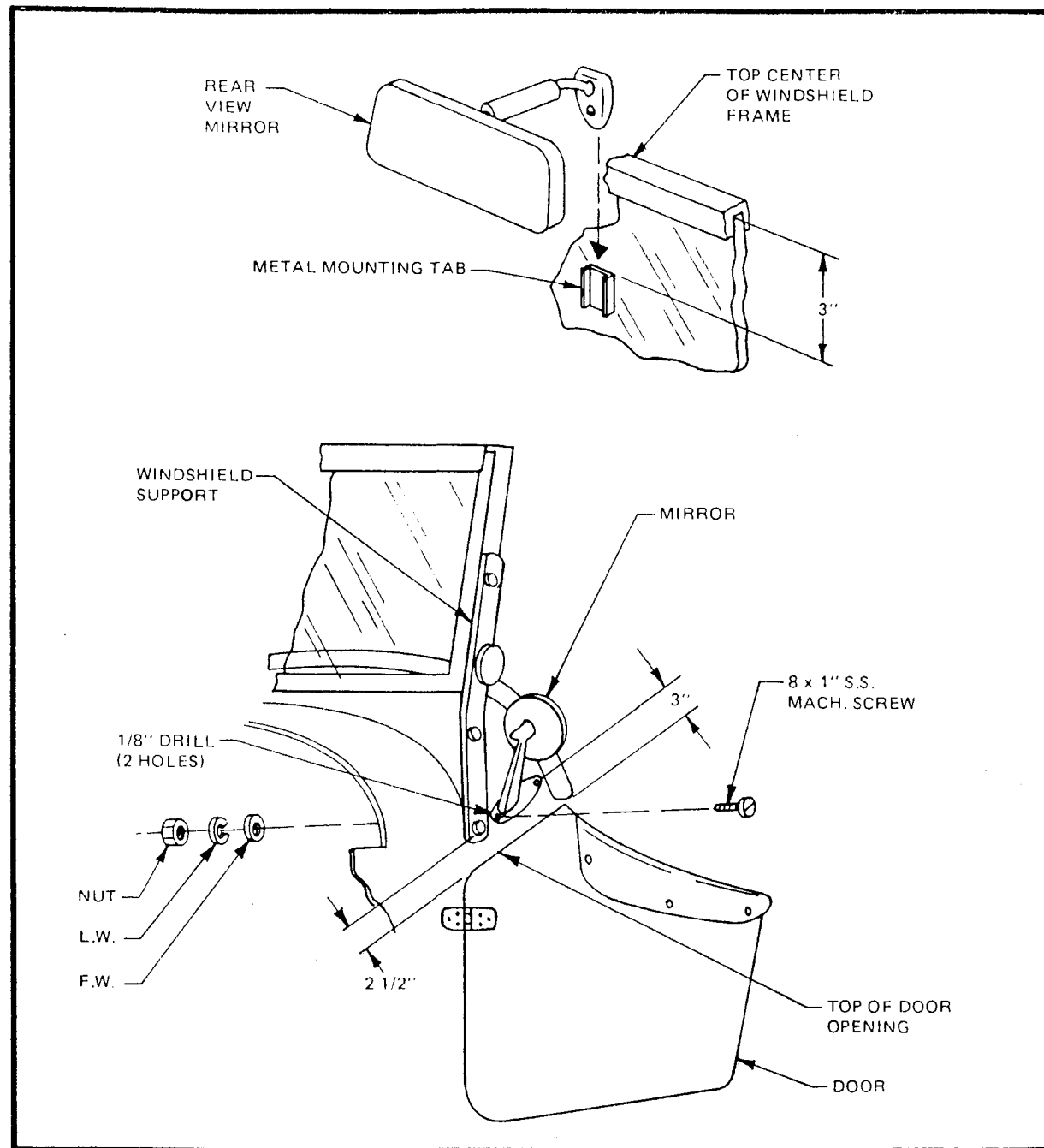

Figure 26

LEATHER HOOD STRAP

- Stretch the leather hood strap across the top of the hood. Mark center of hood loop 18 1/2" from rear of hood. Drill 3/16" holes and install loop with No. 8 x 5/8" stainless steel oval head machine screws, flat washers, lock washers and nuts.
- Insert the strap through the top loop and insert side loops through ends. Mark side loop locations and drill 3/16" holes. Attach with No. 8 x 5/8" stainless steel oval head machine screws.

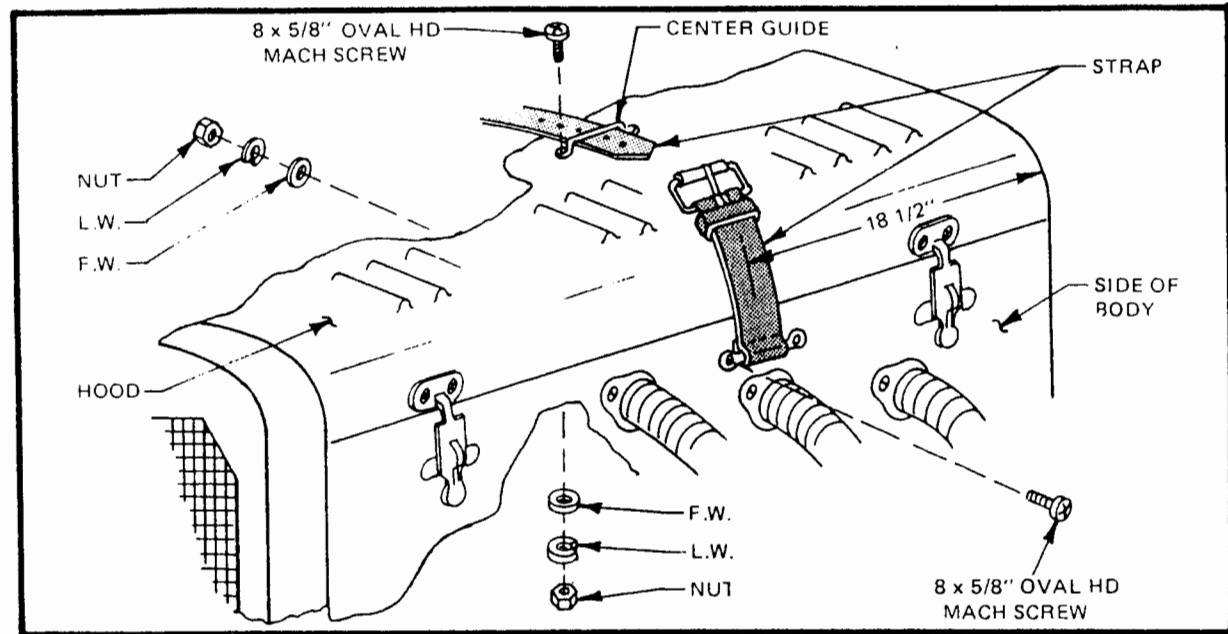

Figure 27

TONNEAU COVER (OPTIONAL)

- Install snaps in tonneau cover to match studs on padded rolls and trunk lid. Start at the rear center and work toward the front of the car. **NOTE:** Make certain that tonneau cover overlaps defroster ducts, if installed.

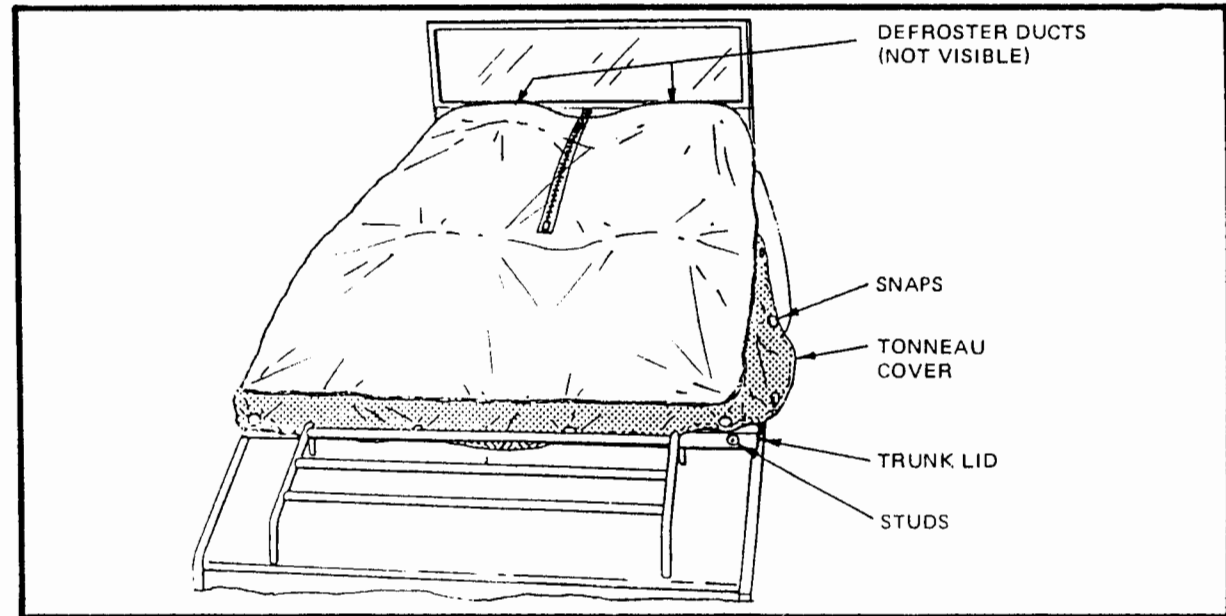

Figure 28

OPTIONAL SPRING LOADED RADIATOR ORNAMENT

- Drill 1/4" hole in center of radiator shell or simulated radiator cap.
- NOTE: Center punch hole before drilling to prevent drill from walking.
- Use two small No. 2 flat head machine screws to secure the chrome bezel.

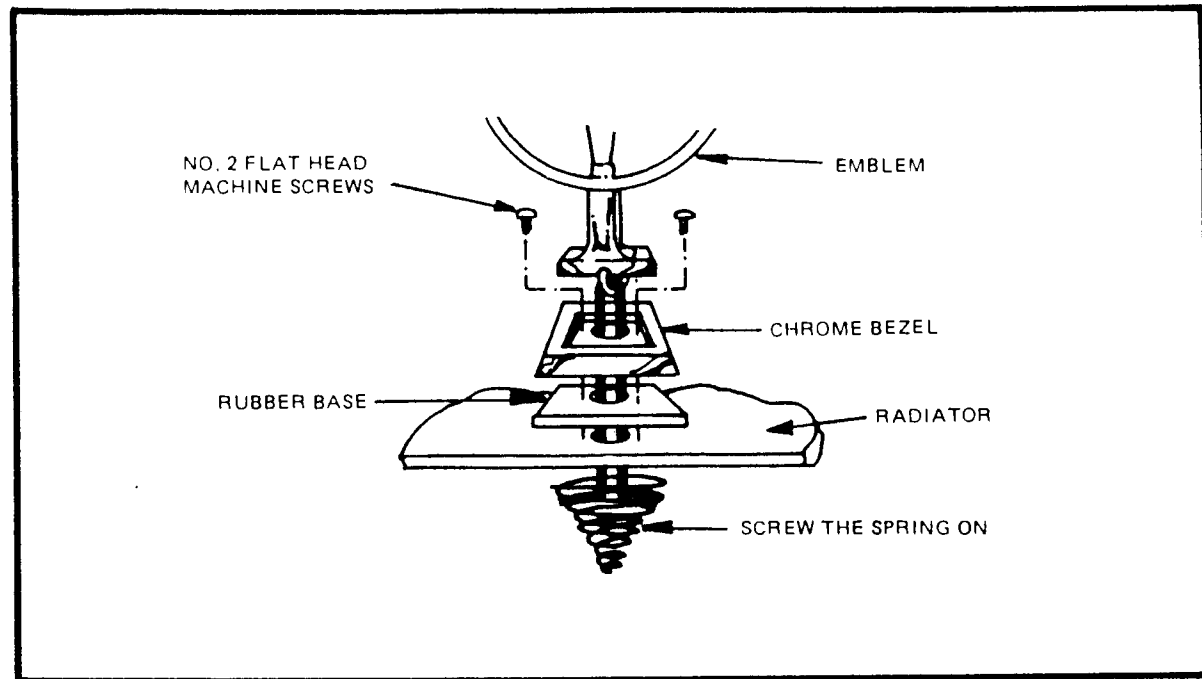

Figure 29

Figure 12

WIRING

Before you start the wiring on your assembly we suggest that you have the following tools and supplies on hand.

TOOLS

Good quality - wire strippers
Good quality - terminal crimping tool
Straight edge razor knife and extra blades
Self-powered test light
12-volt test light

SUPPLIES

Proper terminals - butt connectors, ring terminals
Female disconnects, splice connectors
Electrical tape
Wire ties
6" ground strap to ground transmission to frame

The Chevette wiring as it comes out of the car is the ideal harness to use on the Replica assembly. If custom gauges are to be used a separate harness will have to be fabricated to attach to the Chevette harness. An optional harness for our gauges is available from our factory.

When the engine is removed, the front wiring is disconnected from the lights. The rear fire wall plugs are disconnected and the engine is removed, with all wiring intact.

All under dash wiring is removed, with fuse block and all plugs, relays, flashers, etc. intact.

The rear section wiring is disconnected from the rear lights and fuel tank and all plugs are disconnected. The front to rear wiring runs along the driver's side and is plugged into the fuse block. Remove intact.

Because of mounting differences several wires and connectors on the Chevette under dash harness must be lengthened. (See under dash harness modifications.) After these are made the Chevette under dash harness connects to the instrument harness in two places. The Chevette dash plug wires are attached with butt connectors to their corresponding wires (see dash connector) on the optional instrument harness. The heater power connection is also made but the small Chevette heater harness is not used.

MODIFICATIONS TO CHEVETTE UNDER DASH HARNESS

The distance between the fuse block and engine harness connector must be increased. There are four wires that must be cut and lengthened with appropriate lengths of the proper gauge wire attached to each end of the cut wires with butt connectors. Untape harness wires between these two pieces. Cut the wires. Spread the two pieces as far apart as you can. Reconnect and tape wires.

NOTE: There are two brown wires. When you cut the first, attach connector to each end to identify the wire. Cut odd lengths.

Brown - 16 gauge
Brown - 16 gauge
White - 16 gauge
Pink/Blk - 10 gauge

The following connections also must be lengthened (Figure 1). This is accomplished in the same manner.

Headlight Switch Connector - to headlight switch, lengthen 24"
Washer Wiper Switch Connector - to bottom of steering column, lengthen 18"
High-Low Beam Switch Connector - to left side of steering column - lengthen 18"
Diagnostic Connector - mounts to left lower steering column support brace, lengthen 18"

The following items connect directly to their corresponding wires on the Chevette harness:

Cigarette lighter
Radio - (grey wire not used)
Headlight switch

Wire all switches as per instructions.

NOTE: Chevette headlight switch is ideal and may be used, if desired; simply plug back into connector.

DASH CONNECTOR

Dash Harness

Grey	Gnd for bk light	Bl/Wh*
Red/Yel	Brake light	Tan/Wh
Red	Power to instr.	Pink/Bl*
Yellow	From fuel sender	Pink
Red/Gn	From pres. sender	Tan
Black	Ground for inst.	Bl/Wh*
Red/Bl/Wh	From temp. sender	Dk Grn
Wh/Bl	High beam ind.	Lt. Grn
Grn/Red	Left turn ind.	Lt. Blu
Grn/Bl	Right turn ind.	Dk. Blu
Brown	Instrument lights	Grey
Red/Blu	Power to fog lights	Pink/Bl*

Chevette

NOTE: There are two pink/Bl wires and two Bl/Wh wires at the plug. Both are used and connections may be made to either one.

REAR HARNESS

- Plug front to rear feed harness back into socket on fuse block. Unplug the small connector attached to feed harness (Orn, Wh, Tan wires attached) and discard.
- Route to rear of car and plug into rear harness.
- Remove large rubber grommet behind plug.
- Rear harness connections are as follows:

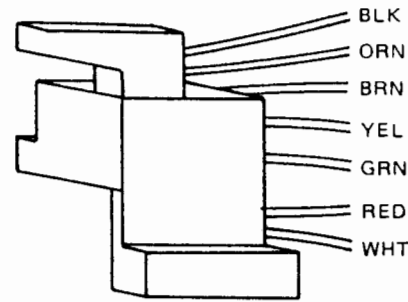

HEADLIGHT SWITCH

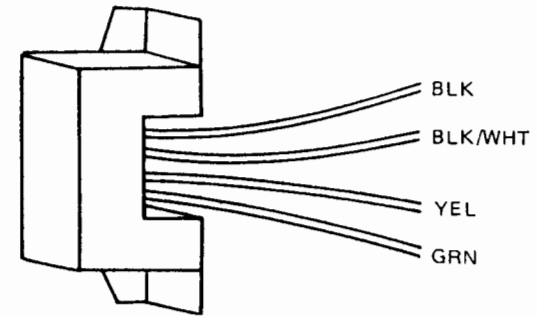

DIAGNOSTIC SWITCH

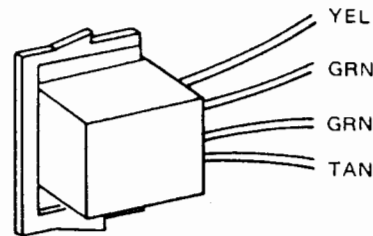

HIGH-LOW BEAM SWITCH

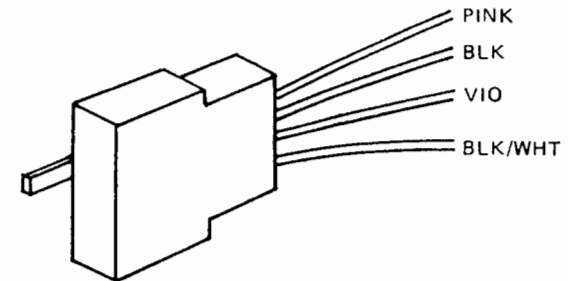

WIPER WASHER SWITCH

Figure 1

Left rear taillight Yellow Stop and turn signal
 Brown Park
 Bl Ground

Right rear taillight Dk Grn Stop and turn signal
 Brown Park
 Black Ground

Backup lights Lt Grn
 Black

Fuel Sender Pink

License Light Brown
 Black

HEATER

Dash
 Harness Chevette

Connect: Red/Vio - Brown connector
 Blue - To heater

The Brown connector is separate from the dash connector and is located on the Chevette harness approximately 4-5" from where the dash connector branches off.

NOTE: On some Chevette rear harnesses the colors will be slightly different. The General Motor's substitutions are as follows:

Yellow or Bl/Yel
 Dk Grn or same
 Brown or same
 Lt Grn or Bl/Grn
 Pink or Bl/Pink

There will be a number of brown wires and a number of black wires left over. These are for Chevette running lights and are not used. Cut and tape them so they won't short out.

FRONT HARNESS CONNECTIONS

Front connections are already attached to the engine harness. Route along left side of frame to front. Connect as follows:

HEADLIGHTS

Chevette

Grn - High beam
 Tan - Low beam
 Black - Ground

LEFT FRONT TURN SIGNAL

Brown - Park
 Lt Blu - Signal
 Black - Ground

RIGHT FRONT TURN SIGNAL

Brown - Park
 Dk Blu - Signal
 BL - Ground

Also off the front harness you will find a dark green wire for the horns and a plug with a pink wire and a white wire attached for the windshield washer pump. All other wires are for Chevette running lights and are not used. Tape them up to prevent shorts.

By each of the headlight plugs there will be an extra black ground wire. Extend and secure to frame.

WINDSHIELD WIPER

Locate 3 wires coming out of the fire wall plug on the engine side. They are purple, white and grey, and are probably enclosed in their own tubing and terminate in a single connector. Route back through fire wall and connect to VW windshield wiper motor assembly.

WIRING HARNESS VW WIPER MOTOR

White to Ground - (31) Brown
 Purple to High - (53B) Black/Yellow
 Grey to Low - (53) Black

FOG LIGHTS

Route yellow/black wire from dash harness through fire wall and down along left frame member to front of car. Connect to fog lights. (Attach a wire to the mounting post of the fog lights and ground to frame.)

AMP GAUGE

Route orn/red and orn/blk wires from the harness through the fire wall. Remove orange 10 gauge wire from battery side of starter solenoid. Attach orn/red to terminal post and connect orn/blk to orange wire removed from post.

TACHOMETER

Route green wire through fire wall. Locate white wire coming out of test plug and splice green wire in.

On the small 3-wire plug going into the rear harness connector at the fuse block, cut and tape the orange and white wires. Ground the black wire to the chassis or other suitable ground.

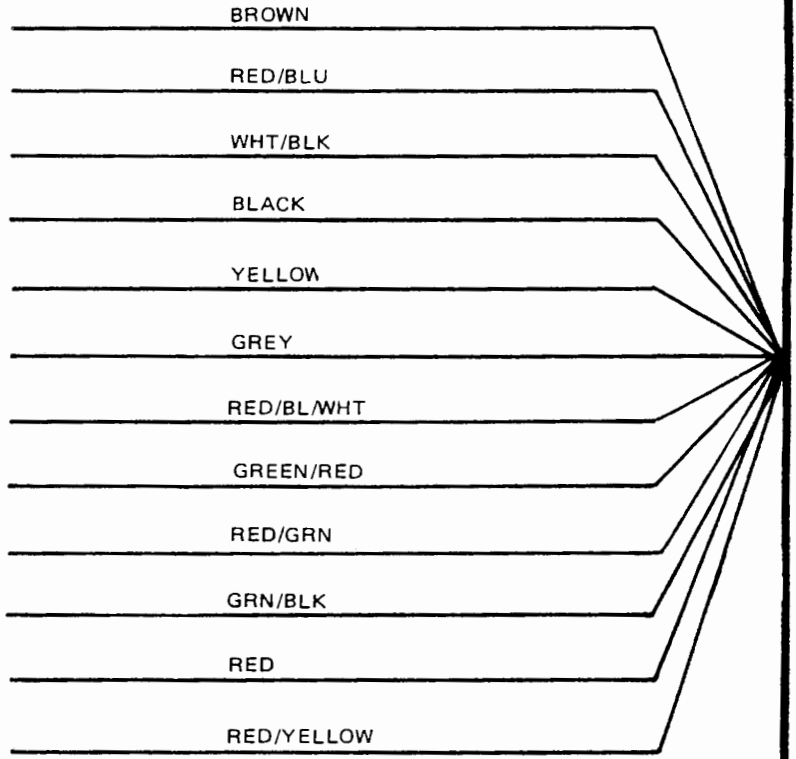
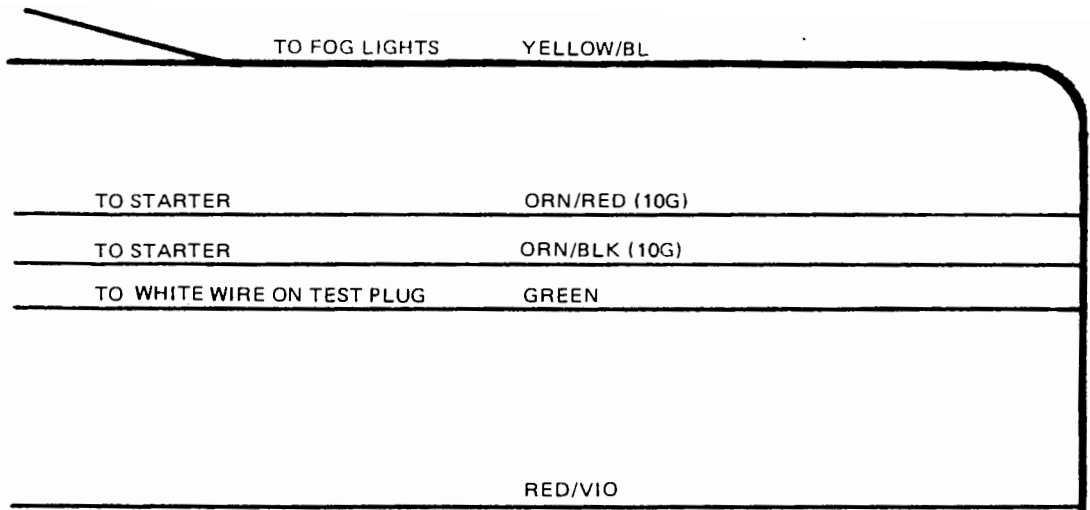

CLASSIC HARNESS

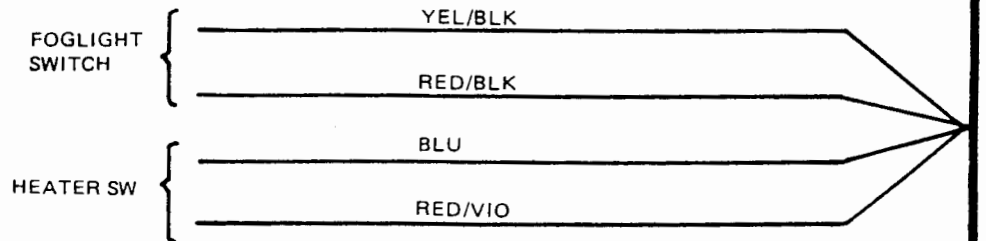

TO INSTRUMENT CONNECTIONS

7-4

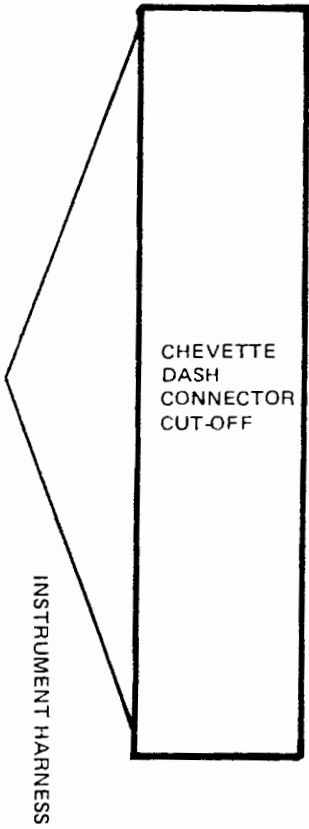

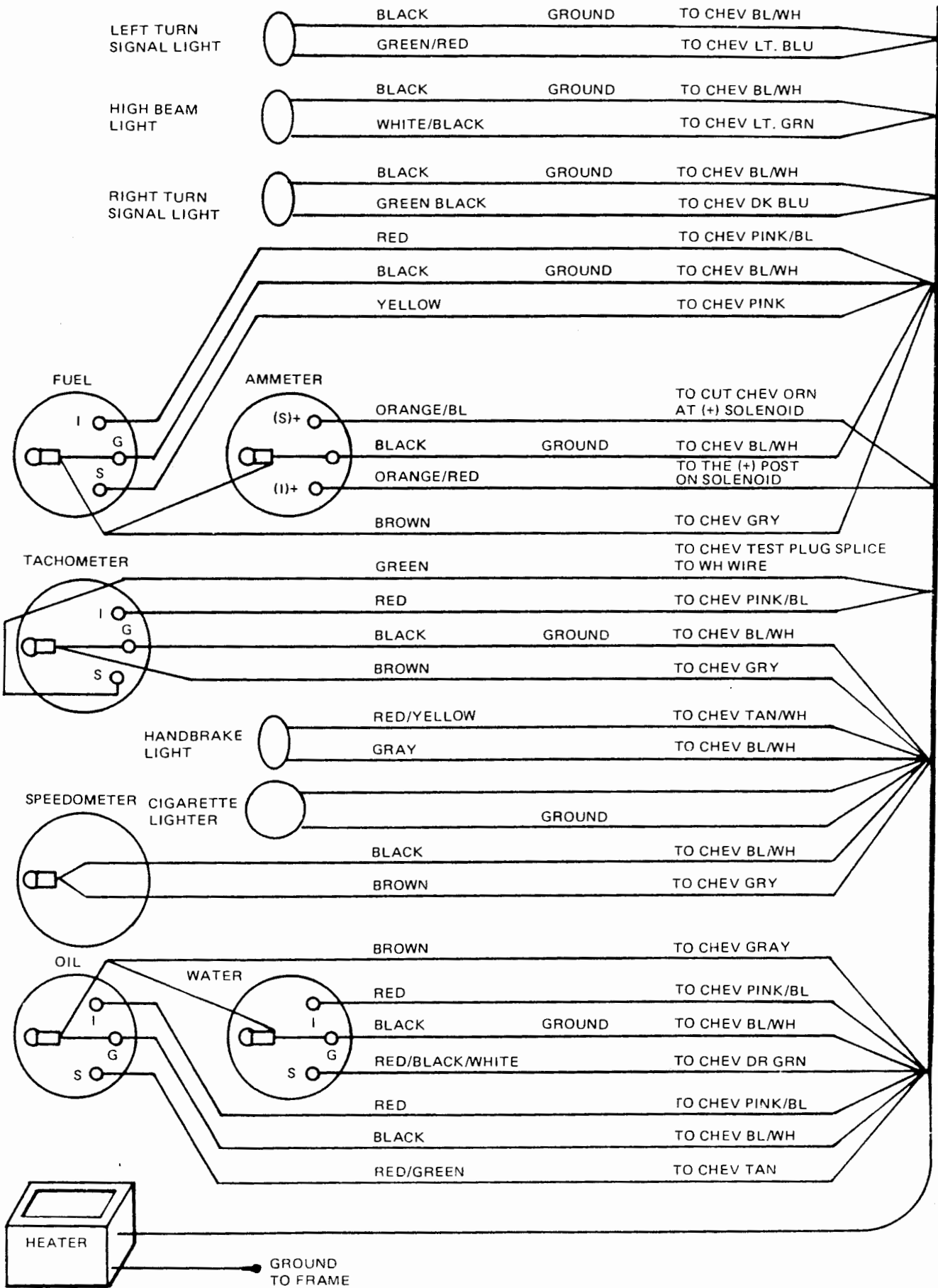

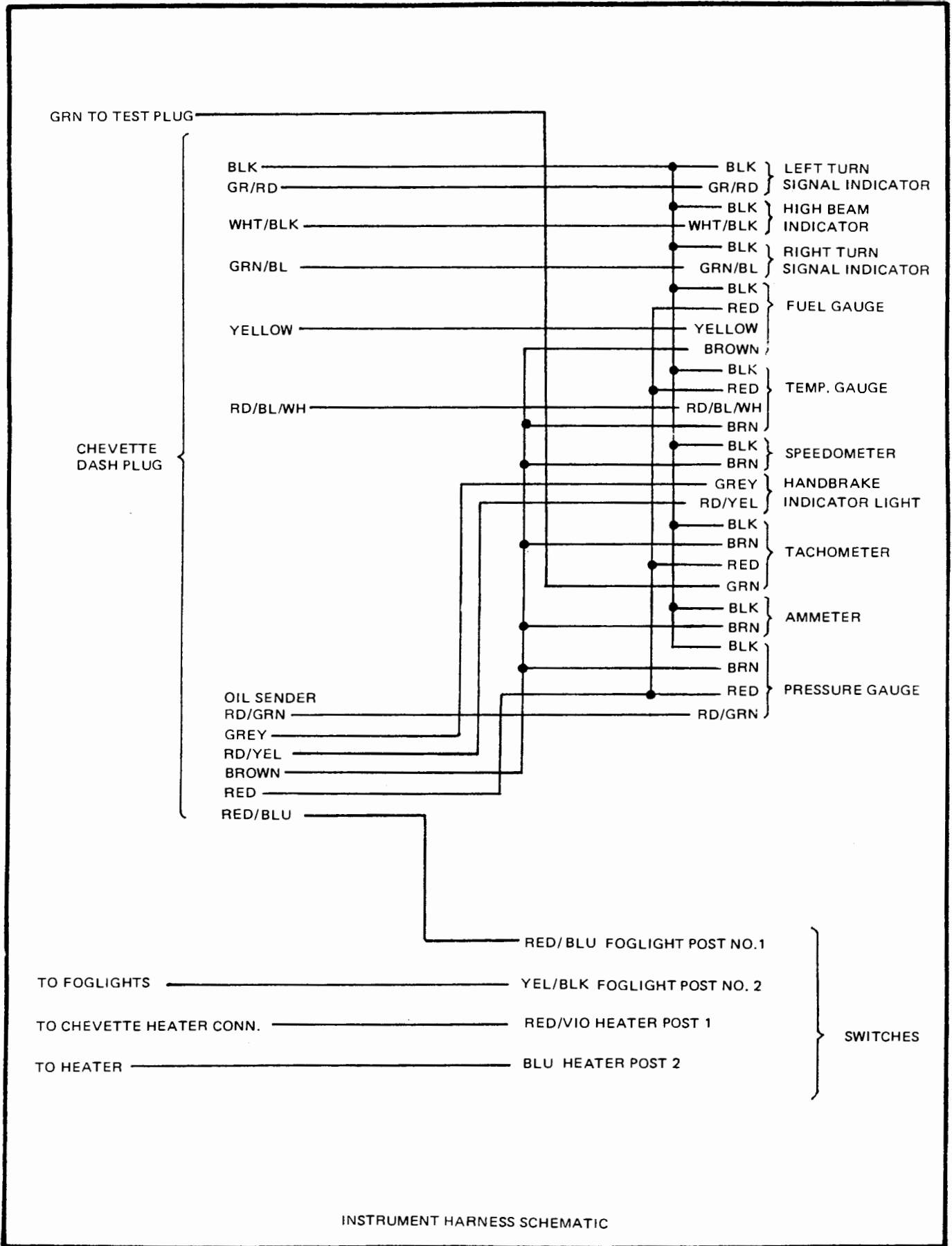

INSTRUMENT HARNESS SCHEMATIC

NOTE: The Instrument Harness can be divided into 4 main groups.

- ① Instrument Harness Engine Connections
- ② Connections to Chevette Harness
- ③ Switches
- ④ Instruments

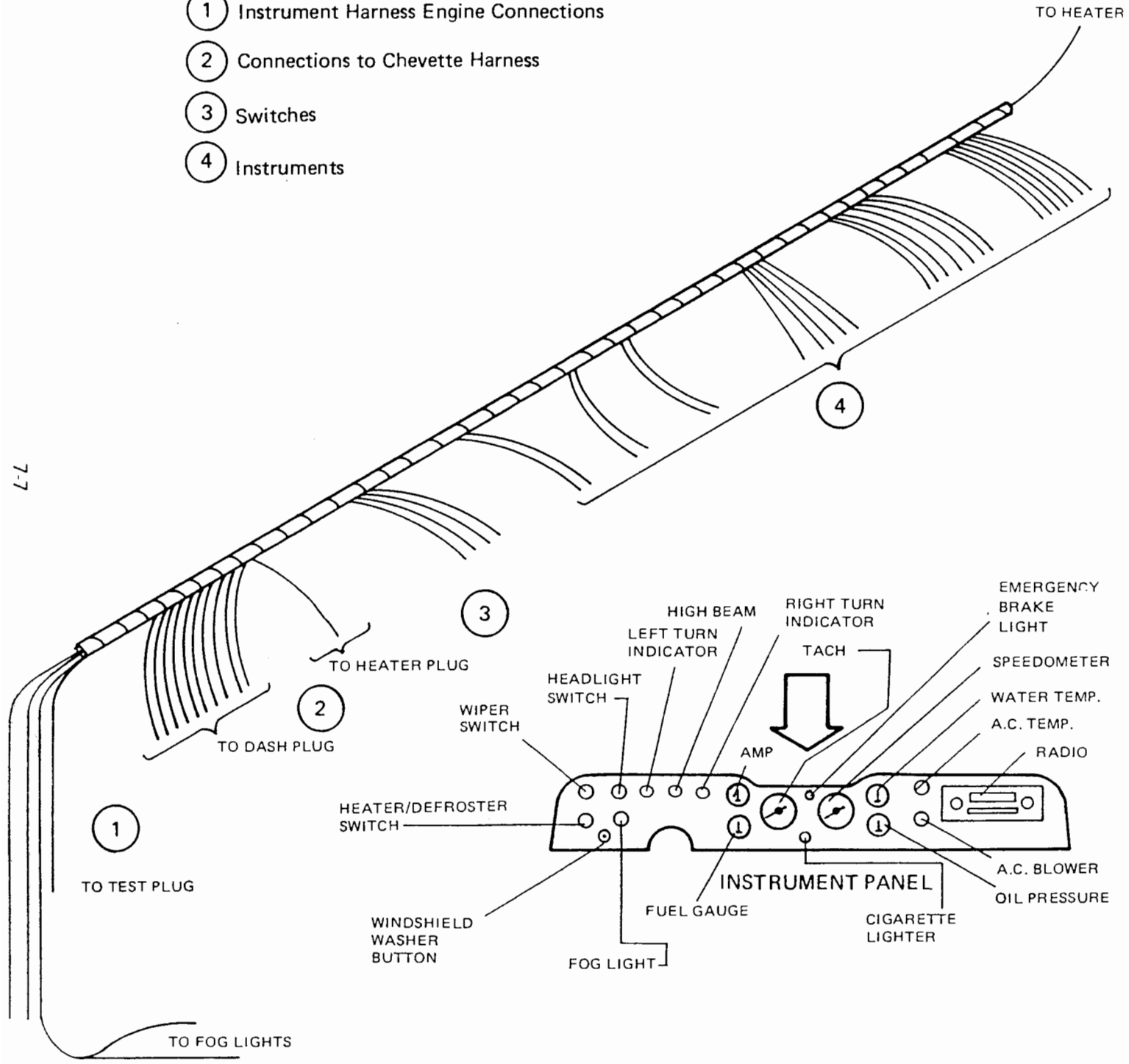

7-7

TO ALTERNATOR

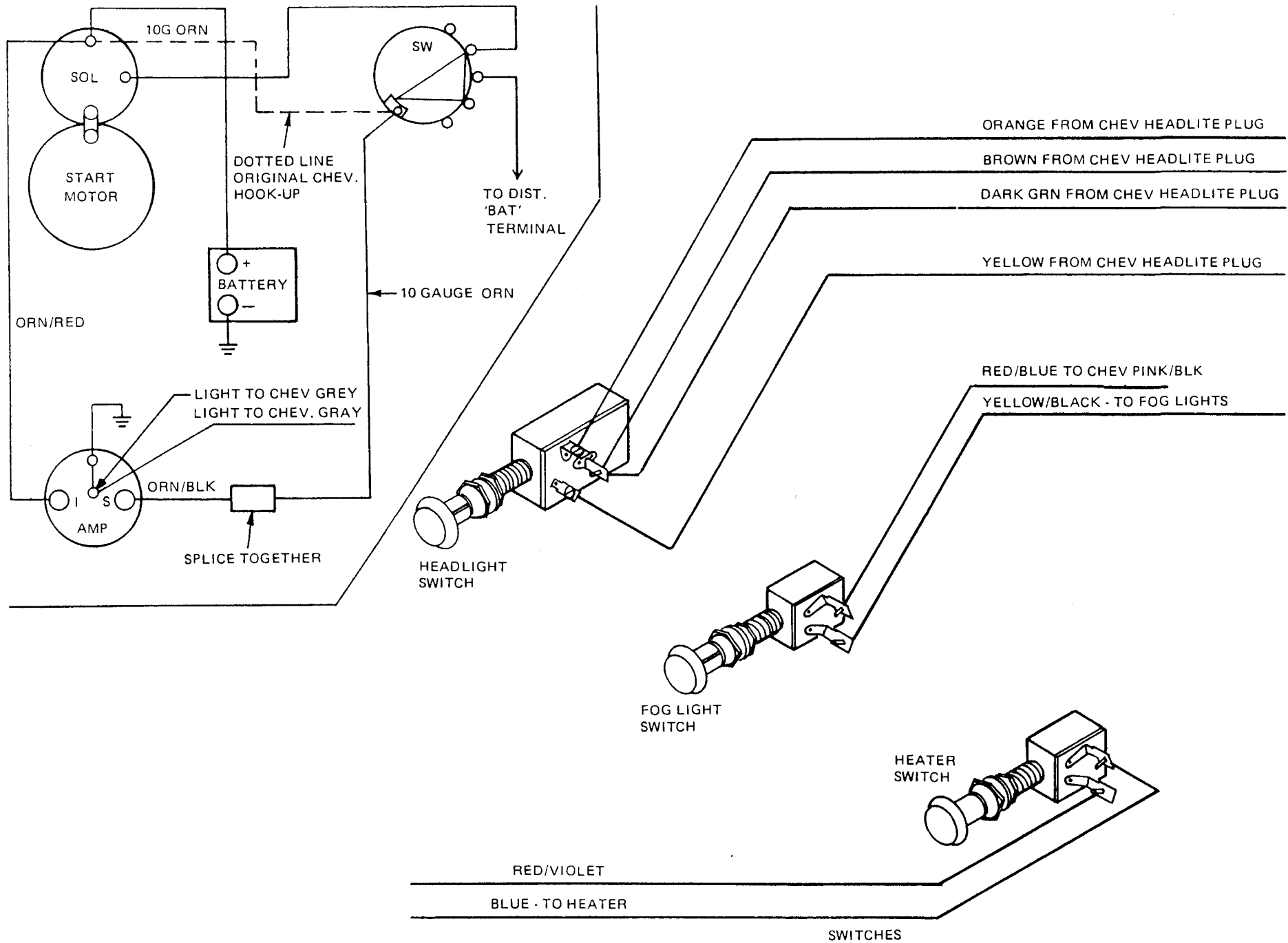

FIBERGLASS CARE AND REPAIR

TYPES OF FINISHES

Parts are made of molded fiberglass. There are 3 types of fiberglass material finishes:

1. Gel Coat finish: This finish is made of a special pigment and blended polyester resin several thousandths of an inch thick.
2. Molded-in-Color finish: This finish is molded into the fiberglass material which is the same color throughout its thickness.
3. Painted finish: This finish is painted on the natural color fiberglass material using standard painting procedure.

CARE OF FINISHES

The Gel Coat and molded-in-color finishes require minimum care and can be kept looking new by following these easy maintenance rules:

Clean, buff and wax the exterior periodically to renew finish.

An automotive wax type cleaner containing fine rubbing compound is suitable for removing minor scratches and scuffs. Scratches which are not removed by the rubbing compound can be removed by wet sanding with 400 grit sandpaper. Then wet sand with 600 grit sandpaper, rebuffer and apply wax polish.

Care should be taken not to cut through the gel coat surface when rubbing. A power buff

fer may be used with care or the surface may be buffed by hand, using a rubbing compound.

REPAIRS

Patch and fill in deep scratches, scars and small breaks.

Repair any major breaks as soon as possible to avoid any additional damage.

For damage to the gel coat finish, a can of Gel Coat of the same color and a small amount of catalyst is needed. For damage to the molded-in-color surface, a can of Filler Coat of the same color and a small amount of catalyst is needed. For deep holes, breaks, or gouges, some fiberglass mat and pre-accelerated polyester resin will also be required. Use M.E.K. (methyl ethyl ketone) catalyst.

The other materials including fiberglass mat, and pre-accelerated polyester resin are supplied in fiberglass repair kits which are available at most marine or automotive supply stores.

Damage to the painted type finish can be repaired by sanding, priming and painting using regular painting procedure.

SURFACE FINISHING

GEL COAT TOUCH-UP AND SURFACE REPAIRS

This type of damage may be classified as damage to the gel coat only, or a hole or

gouge that is deep enough to slightly penetrate fiberglass material. Repair as follows:

1. To be sure that the area to be patched is dry, clean and free of any wax or oil, wash with lacquer thinner.
2. Roughen the bottom and sides of the damaged area, using a power drill with a burr attachment. Feather the edge surrounding the scratch or gouge, being careful not to undercut this edge. (See Figure A)
3. A small amount of gel coat, the same color as the finish should be placed in a small can lid or on a piece of cardboard. Use just enough to fill the damaged area. If damage has penetrated through to fiberglass material, an equal amount of fibers, which can be taken from glass mat and shredded into small fibers, should be mixed with the gel coat - using a putty knife or flat stick. Add three drops of catalyst per teaspoon of gel coat using an eye dropper. Be sure to mix the catalyst thoroughly for maximum working time. Maximum working time (pot life) will be about 15 to 20 minutes at which time it begins to "gel". (See Figure B)
4. Fill the scratch or hole above the damaged area about 1/16", working the material into the damaged area with the sharp point of a knife. Be careful to puncture and eliminate any air bubbles which may occur. (See Figure C)

NOTE: If fiberglass fibers have not been used in mixture, skip steps 5 through 7 and proceed with step 8.

5. When the patch feels rubbery to touch (10-15 minutes), trim the patch flush with the surface, and then allow to cure completely (30-60 minutes). Patch will shrink slightly as it cures, making a depression. (See Figure D)

6. Carefully roughen up the bottom and edges of the depression, using the electric drill with burr attachment, as in Step 2. Feather into surrounding gel coat; do not undercut.

7. Again mix a small amount of gel coat with catalyst - do not use glass fibers. Using your

finger or putty knife, fill the depression with gel coat 1/16" above the surrounding surface.

8. Spread the gel coat level with the surrounding area and allow to cure (30 - 60 minutes). (See Figure E) Gel coat can be covered with cellophane, if desired, to aid in spreading evenly. Remove cellophane after gel coat has cured.

9. Sand the patched area, using a sanding block with 600-grit wet sandpaper. Finish by buffing with fine rubbing compound such as DuPont No. 606 and waxing. Weather-

ing will aid to blend touch-up; if a slight color difference can be observed. (See Figure F)

NOTE: Where surface color of part has changed due to weathering, color match of patch may not be satisfactory. In this case, entire panel must be sprayed.

Thin Gel coat with acetone (1 to 1 ratio) and spray panel, blending sprayed area into a radius or corner on the part. Use a touch-up spray gun such as the Binks Model 15. After Gel coat is hard, buff and polish sprayed area.

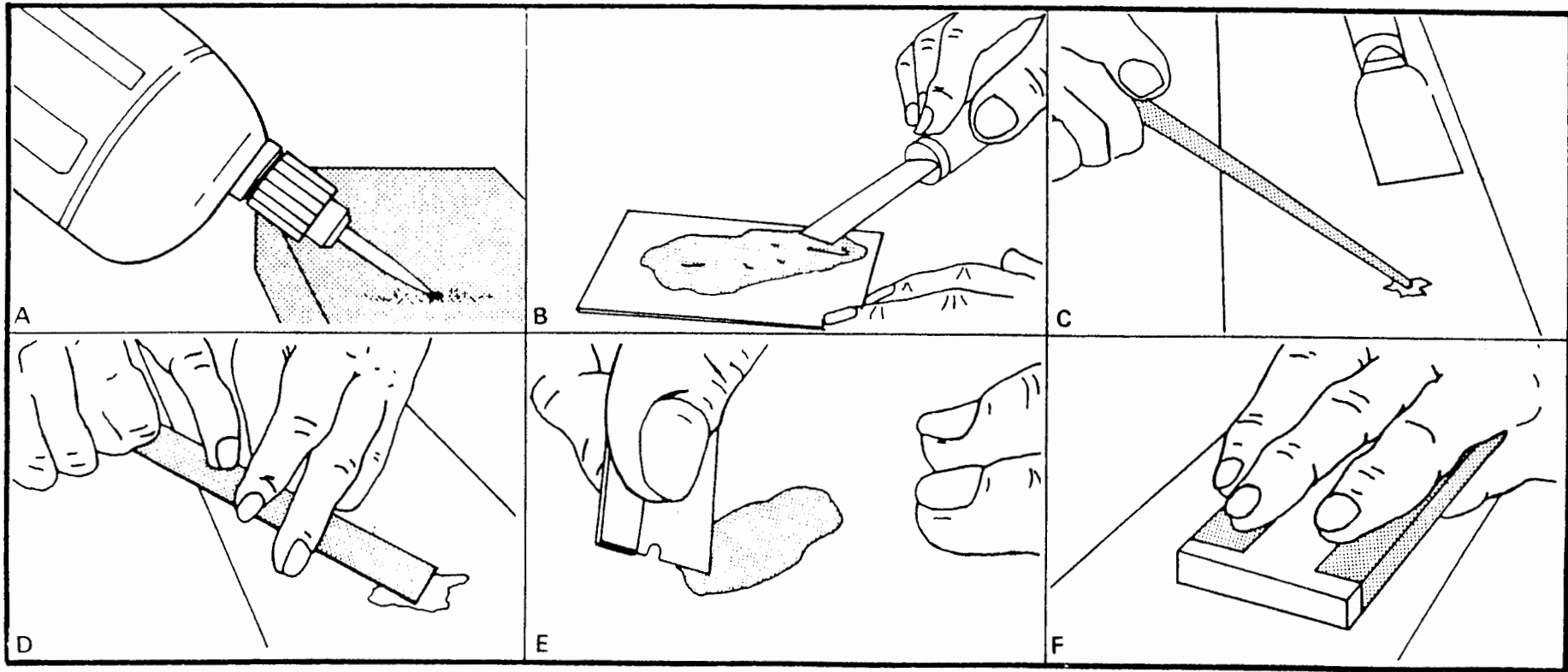

Figure 1

PRE-OPERATIONS CHECK LIST

Before putting your car into service be sure:





- | | | |
|--|---|---|
| <input type="checkbox"/> All bolts are tightened properly. | <input type="checkbox"/> Front end is properly aligned. | <input type="checkbox"/> Catalytic converter to transmission. |
| <input type="checkbox"/> All parts are lubed where required. | <input type="checkbox"/> All belts are tightened properly. | <input type="checkbox"/> Rear lower control arm to chassis. |
| <input type="checkbox"/> Brakes have been bled and adjusted properly. Master cylinder is full. | <input type="checkbox"/> Headlights are adjusted. | <input type="checkbox"/> Rear tie rod to chassis. |
| <input type="checkbox"/> Engine oil level is correct. | <input type="checkbox"/> Horns and all safety items function properly. | <input type="checkbox"/> Front gas tank straps to chassis. |
| <input type="checkbox"/> Transmission oil level is correct. | <input type="checkbox"/> Car meets your state safety and emission requirements. | <input type="checkbox"/> Brake pedal assembly to chassis. Factory studs and master cylinder to pedal assembly - factory nuts. |
| <input type="checkbox"/> Tire inflation is at 28 psi (recommended) | | <input type="checkbox"/> Front shocks to lower shock mounts. |
| <input type="checkbox"/> Battery is charged and alternator is charging battery. | | |

NOTE: The following hardware should be saved and retained from your component car. Replace where required with GM hardware.

NOTE: Some parts in the assembly are packed with their own hardware and some optional accessories include their own hardware. This hardware is not included in the nut and bot kit.

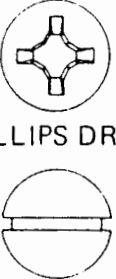
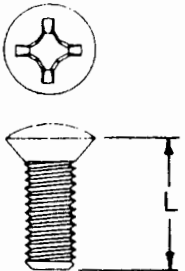
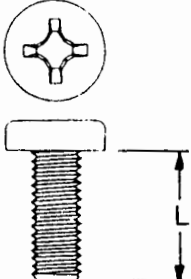
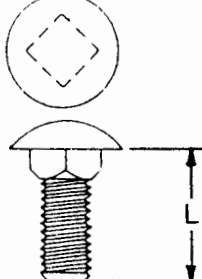
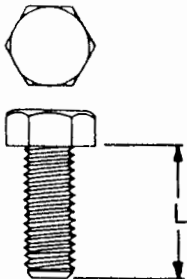
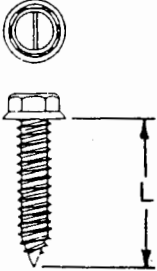
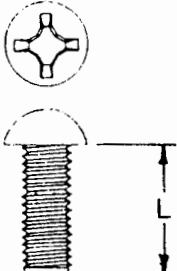
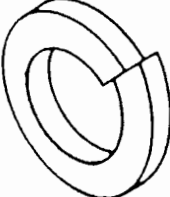
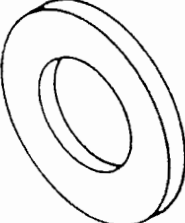
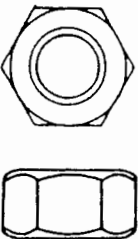
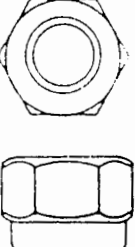
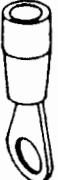
- Cross member to chasis.

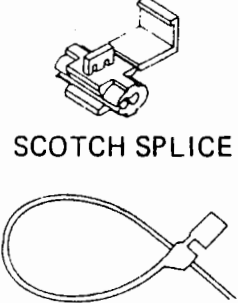
HARDWARE

 <p>PHILLIPS DRIVE</p> <p>SLOT DRIVE</p>	 <p>OVAL HEAD</p>	 <p>PAN HEAD</p>	 <p>CARRIAGE HEAD</p>	 <p>HEX HEAD</p>
 <p>HEX HEAD WASHER SHEET METAL SCREW</p>	 <p>ROUND HEAD</p>	 <p>SPRING LOCK</p>	 <p>FLAT</p>	 <p>HEX NUT</p>
 <p>LOCK NUT</p>	 <p>RING TERMINAL</p>	 <p>PUSH ON TERMINAL</p>	 <p>SCOTCH SPLICE</p> <p>WIRE TIE</p>	 <p>BUTT CONNECTOR</p>

NUT AND BOLT LIST

1. Motor Mount to Chassis - (2 each) 10mm jam nut and 7/16" internal star lockwashers.
2. Trans Support to Chassis (4 each) 5/16 x 1 1/4" hex head cap screw, flatwasher, lockwasher, nuts.
3. Differential to forward mounts (2 each) 3/8 x 1 1/4" hex head cap screw, flatwashers, lockwashers and nuts.
4. Rear gas tank straps to chassis (2 each) 3/8 x 2 1/2" hex head cap screw, flatwasher, lockwasher and nuts.
5. Steering column to chassis - 2 3/8 x 1 1/2" hex head cap screws, 4 flatwashers, 2 lockwashers, 2 nuts. 1 5/16 x 1 1/4" hex head cap screw, 2 flatwashers, lockwasher, nut.
6. Pillow block bearings to chassis (3 each) 3/8 x 1 1/2" hex head cap screws, flatwasher, nuts. (1 each) 3/8 x 4" hex head cap screw, flatwasher, lockwasher, nut.
7. Accelerator pedal to firewall (2 each) 1/4 x 1 1/4" hex head cap screw, flatwasher, lockwasher, and nut.
8. Brake differential valve to chassis (2 each) 5/16 x 1" hex head cap screw, flatwasher, lockwasher, nuts.
9. Front brake hose mounts to chassis (2 each) 5/16 x 1" self-tapping screws.
10. Emergency brake cable mounts to chassis (4 each) 5/16 x 1 1/4" hex head cap screw, flat washer, lockwasher and nuts.
11. Rear shock plates to rear end (4 each) 5/16 x 1 1/4" hex head cap screw, flatwasher, lock washer, nuts.
12. Rear shocks to plates (4 each) 5/16 x 1 1/4" hex head cap screw, flatwasher, lockwasher and nuts.
13. Rear brake hose mount (2 each) 5/16 x 1" self-tapping screws.
14. Front shock mounts to A frame (8 each) 5/16 x 1 1/4" hex head cap screw, flatwasher, lockwasher and nuts.
15. Shifter to liner (4 each) 5/16 x 1" hex head cap screw, flatwasher, lockwasher, and nuts.
16. Liner to chassis (22 each) 5/16 x 1" self-tapping washer hex head screws.
17. Liner to firewall (6 each) 1/4 x 1" cap screw, flatwasher, lockwasher and nuts.
18. Emergency brake lever to fiberglass bracket - 2 5/16 x 1 3/4" hex head cap screws, 4 flatwashers, 2 lockwashers, 2 nuts.
19. Emergency brake support bracket to floor (12 each) 1/4 x 1 1/4" round head mach. screw, lockwasher and nuts. (24) flatwashers.
20. Radiator bracket to frame (2 each) 5/16 x 1 3/4" hex head cap screw, flatwasher, lockwasher, and nuts.
21. Radiator bracket to frame (2 each) 5/16 x 2" hex head cap screw, flatwasher, lockwasher, nuts.
22. Radiator top plate to bracket (2 each) 5/16 x 1 1/2" hex head cap screw, flatwasher, lockwasher, and nuts.
23. Wiring plug to battery box (2 each) 1/4 x 1 1/2" hex head cap screws, flat washer, lockwasher, and nuts.
24. Fuse box to chassis (2 each) 1/4 x 2 1/4" hex head cap screw, flat washer, lock washer and nuts.
25. Standard front bumper bracket to chassis (4 each) 1/2 x 1 1/4" hex head cap screw, flat lock nuts.
26. Standard front bumper studs to bumper bracket (2 each) 5/16" flatwasher, lockwasher and nuts.
27. Standard rear bumper brackets to frame (4 each) 3/8 x 1 1/2" hex head cap screw, flatwasher, lockwasher and nuts.
28. Rear bumper mounting tabs to bumper bracket (4 each) 3/8 x 1 1/2" hex head cap screw, flatwasher, lockwasher and nuts.
29. Standard bumper studs to bracket mounting tabs (4 each) 5/16" flatwashers, lockwashers and nuts.
30. Front fenders to body - 32 5/16 x 1 1/4" hex head cap screws - 64 flat washers, 32 lockwashers, 32 nuts.
31. Rear fenders to body - 20 5/16 x 1 1/4" hex head cap screws, 40 flatwashers, 20 lockwashers, 20 nuts.
32. Hood hinges to hood and body (18 each) No. 8 x 1" stainless steel philips oval head machine screw with flatwasher, lockwasher and nuts.
33. Hood latches to hood and body (8 each) No. 10 x 1" stainless steel philips oval head machine screw with flatwasher, lockwasher and nuts.
34. Dash to body. Eight 1 1/2" philips flat head stainless steel self-tapping screws.
35. Body to chassis rear (2 each) 5/16 x 2" carriage bolts, flatwasher, lockwasher and nuts.
36. Body to chassis front (2 each) 5/16 x 2" carriage bolts, flatwasher, lockwasher and nuts.
37. Rear side inserts to frame (12 each) 5/16 x 1" self-tapping hex washer head screws.

NUT AND BOLT LIST (Con't)

38. Filler neck to body (3 each) No. 8 x 1 1/4" round head S.S. machine screws, flatwashers, lockwashers and nuts.
39. Standard door lock handles to body and striker plates to body (12 each) No. 8 x 1" oval self-tapping screws.
40. Door hinges to doors and body (24 each) No. 8 x 1 1/4" stainless steel philips oval head machine screw with flatwashers, lockwashers and nuts.
41. Hood support rod - 4 No. 8 x 3/4" self-tapping screws.
42. Spare tire mount to body and frame (2 each) 5/16 x 1 1/2" hex head cap screw, flatwasher, lockwasher, nut.
43. Rear tail pipe strap to frame - One 1/4 x 1" hex head cap screw, flatwasher, lockwasher, nut.
44. Spare tire to mount (2 each) 1/2-20 x 1 1/2" fine thread hex head bolt, flat washer, lockwasher and nuts.
45. License plate light to body (2 each) 1/4 x 1" hex head cap screw with flatwasher, lockwasher and nuts.
46. Front fender brackets to frame (2 each) 1/2 x 1" hex head cap screw, flatwasher, lockwasher and nuts.
47. Headlight bracket to fender bracket (2 each) 7/16 x 1" hex head cap screw, flatwasher, lockwasher and nuts.
48. Wood strips to rear seat back 24 No. 10 x 3/4" wood screws.
49. Wood strips to front seat - 24 No. 10 x 3/4" wood screws.
50. Seat liner to frame and trunk - 10 No. 10 x 2" round head self-tapping screws.
51. Rear deck hinges to deck (4 each) No. 10 x 1" stainless steel philips oval head machine screw with flatwasher, lockwasher, and nuts.
52. Rear deck hinge to seat liner (2 each) 1/4 x 1" hex head cap screws with flatwashers, lockwashers and nuts.
53. Rear deck latches to deck and body (8 each) No. 10 x 1" stainless steel philips oval head machine screws with flatwasher, lockwasher and nuts.
54. Seat slides to seats (2 each) 5/16 x 2" carriage bolts, flatwasher, lockwasher and nuts; (2 each) 5/16 x 1" carriage bolts, flatwasher, lockwasher and nuts.
55. Seat studs (4 each) 5/16 x 2" carriage bolt, flatwasher, lockwasher and nuts. (4 each) 5/16 x 6" carriage bolt flat washer, lockwasher and nuts. .
56. Top mounting bracket to seat liner - 2 No. 8 x 2" stainless steel self-tapping screws.
57. Hood straps loops to hood and body (6 each) No. 10 x 1" stainless steel philips oval head machine screw, flatwasher, lockwasher and nuts.
58. Tail lights to rear fenders (4 each) No. 10 x 1 1/4" machine screw with flatwasher, lockwasher and nuts. 2 3/4" machine screws, flatwasher, lockwasher and nut.

NOTE: The nuts and bolts listed here may vary from our optional hardware kit. In addition, many options are supplied with their own hardware and because of variations, the hardware is not listed here.

PARTS IDENTIFICATION

FIBERGLASS COMPONENTS

1. Main Body
2. Left Front Fender
3. Right Front Fender
4. Left Rear Fender
5. Right Rear Fender
6. Left Door
7. Right Door
8. Left Bumper Bracket Cover
9. Right Bumper Bracket Cover
10. Rear Deck Lid
11. Hood
12. Padded Roll Set (5 Piece)
13. Floor Liner
14. Rear Seat Liner
15. Bucket Seats (2)
16. Rear Side Inserts - Left and Right
69. Emergency Brake Insert

METAL PARTS, CHASSIS AND METAL BRACKETS

17. Chassis
18. Front Bumper Brackets (2)
19. Radiator Brackets Left and Right
20. Front Fender Brackets (2)
21. Headlight Brackets Left and Right
22. Rear Bumper Brackets - Tubular Bumper
23. Spare Tire Support
24. Running Board Brackets Optional

CHROME AND DECORATIVE PARTS

25. Radiator (Grille Shell)
26. Headlights (2)
27. Front Parking/Turn Signal Lights (2)
28. Taillights (2)
29. License Plate Holder & Light
30. Badge Bar
31. Windshield Frame and Glass
32. Windshield Supports (2)
33. Knurled Windshield Knobs (2)
34. Door & Hood Hinges (7)
35. Hood & Trunk Latches (4)
36. Brass Padlocks (4)
37. Deck Hinges (2)
38. Dashboard (Prefinished Optional)
39. Outside Door Handle (2)
40. Inside Door Handle (2)
41. Striker Plate (2)
42. Slam Locks Optional
43. Exhaust Stacks Optional
44. Leather Hood Strap
45. Footman Loops for Hood Strap (3)
46. Chrome or Stainless Carriage Bolts (6)
47. Leather or Wood Steering Wheel Optional
48. Windwings Optional
49. Wiper Blades & Arms Optional
50. Luggage Rack Optional Coupe Only
51. Hood Ornament Optional

52. Trumpet Horns - Optional
53. Front Top Bow (Short)
54. Rear Top Bow (Long)
55. Roof Bow Hardware
56. Seat Slides - 2 Sets
57. Front Bumper Tubular
58. Rear Bumpers Tubular Left and Right

UPHOLSTERY TRIM AND TOP

59. Standard Convertible Top (Coupe Optional)
60. Side Curtains Left and Right
61. Front Seat Upholstery
62. Rear Seat Side Upholstery Left and Right
63. Rear Seat Back Upholstery
64. Rear Seat Cushion Upholstery
65. Door Upholstery Left and Right
66. Padded Roll Upholstery
67. Boot Cover Standard (Coupe Optional)
68. Tonneau Cover Standard or Coupe Optional

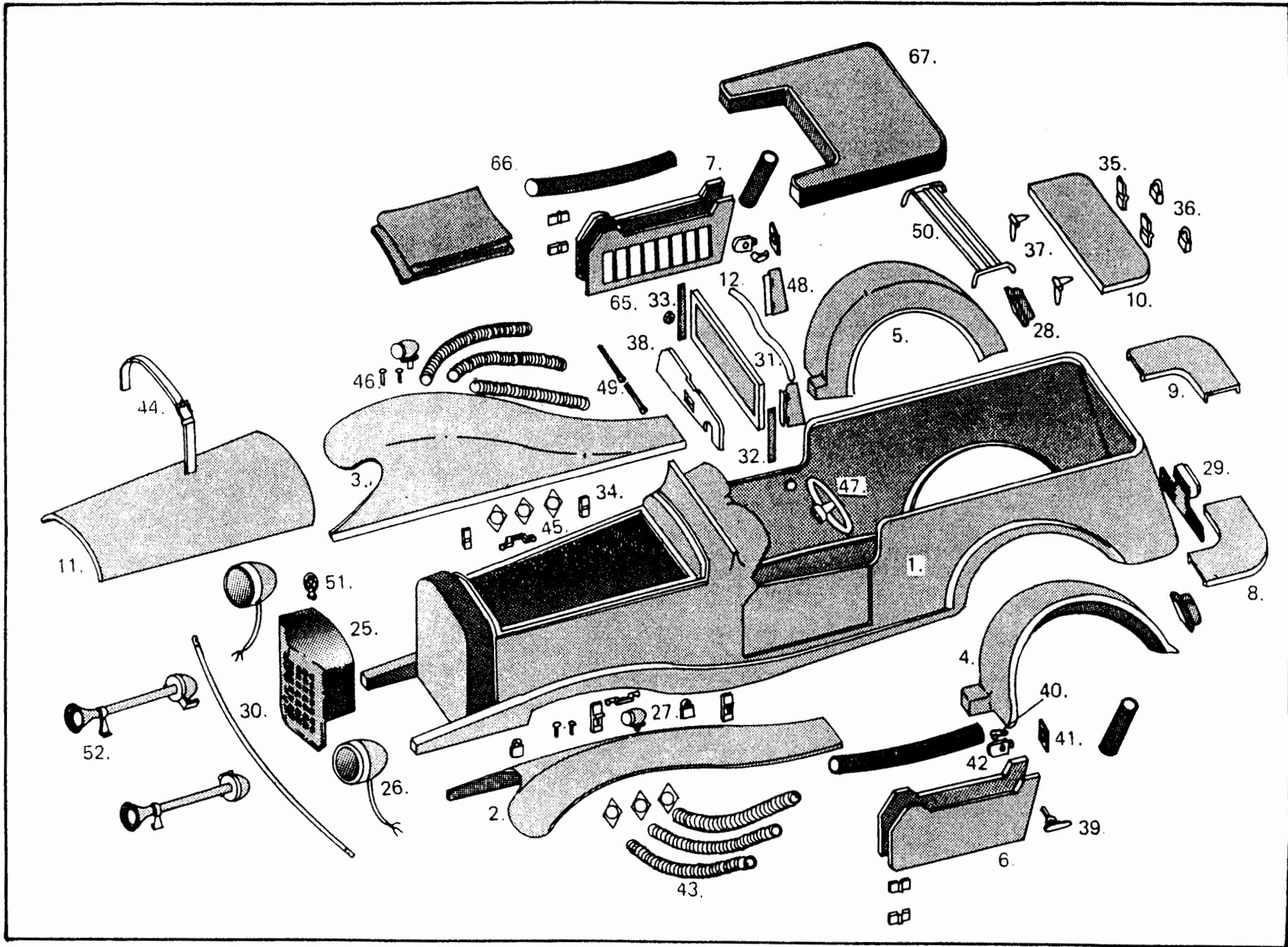

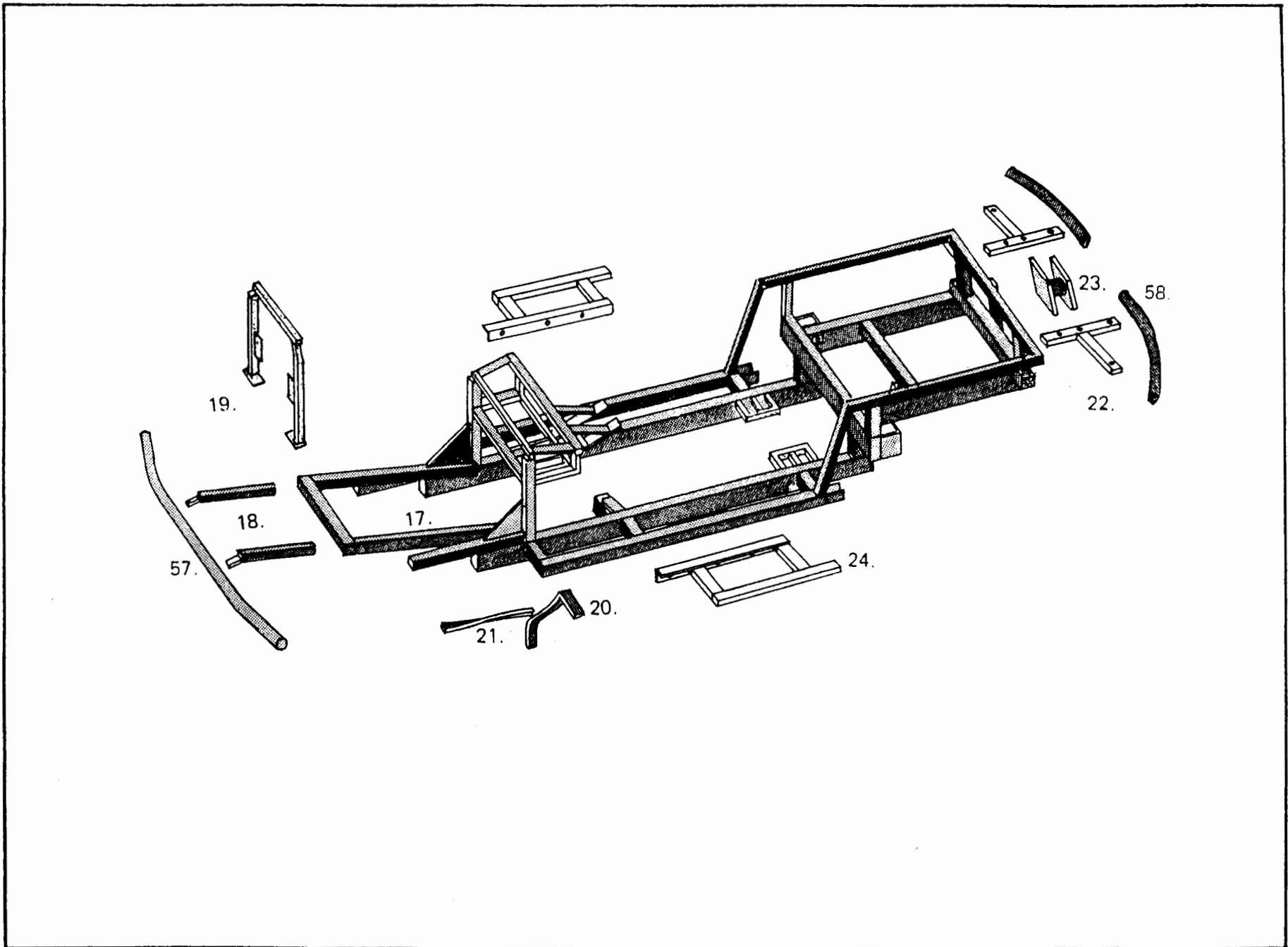

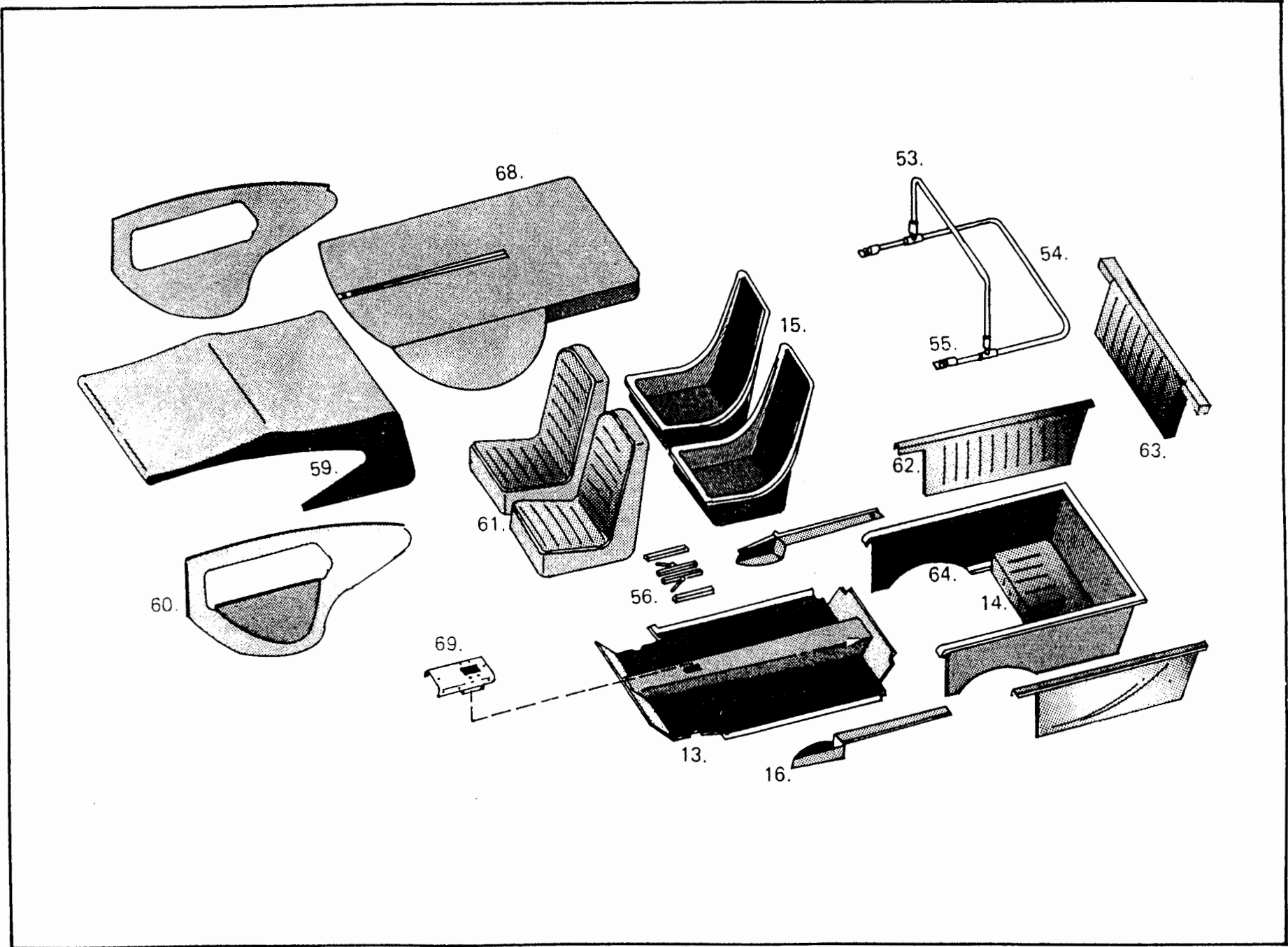

INDEX

Accelerator	3-27	Front Bumper (Standard)	5-16
Accelerator Cable	3-27	Front Cross Member	2-12
Air Conditioner	3-16	Front Fender Brackets	5-19
Antenna (Optional)	6-15	Front Fenders	4-2
Backup Lights	5-18	Front Seat Fabrication	6-9
Badge Bar and Headlights	5-19	Front Shock Mounting	3-10
Battery Box And Computer	3-20	Front Springs	3-10
Body Assembly	4-2	Front Suspension	3-3
Body Attachment	5-5	Fuel Filler Neck	5-7
Body Cutouts	4-4	Fuse Block And Underdash Harness	3-19
Boot Cover	6-24	Gas Tank	2-2
Brake And Fuel Lines	3-8	Gas Tank	5-4
Carpeting	6-1	Glassing The Body	5-18
Chassis Assembly (Rear End)	3-1	Gauge Sender Installation (If Using Optional Gauges)	3-12
Checking The Components	2-12	Hardware	8-4
Chevette Disassembly	2-1	Hardware And Fasteners	1-5
Chrome License Assembly	5-19	Heater (Optional)	3-26
Considerations When Buying A Chevette	1-3	Hood Ornament	4-11
Convertible Top	6-19	Hood Button Modification	6-12
Coupe Top	6-21	Installing Windshield Wiper Motor	4-9
Dashboard Assembly And Wiring	4-7	Interior Liner	3-21
Dashboard Attachment	4-8	Leather Hood Strap	6-26
Defroster Duct Installation	4-9	Luggage Rack (Coupe Top)	6-24
Door Cut Outs	5-7	Mating Body To Chassis	5-1
Door Fabrication (Optional Slam Lock)	5-11	Mirrors	6-25
Door Hinges	5-11	Motor Mounts	3-6
Door Installation	5-13	Mounting The Hood	4-10
Door Trim Strips	6-18	Nut And Bolt Kit	8-5
Drive Shaft Shortening	3-18	Optional Badges & Fog Lights	5-20
Emergency Brake Cables	3-23	Other Accessories	3-27
Engine Compartment	2-5	Padded Roll	6-14
Engine Installation	3-9	Painting	3-27
Exhaust	2-4	Painting	4-10
Exhaust Stacks (Optional)	4-4	Parking Lights	4-7
Exhaust System	3-12	Parts To Be Purchased	1-1
Fiberglass Care and Repair	8-1	Pedal And Master Cylinder	3-6
Fiberglass Preparation	4-1	Pedal Assembly	2-11
Firewall	3-5	Pre-Operations Check List	8-3
Final Alignment	5-20	Pressure Sender	3-12
Flat Bar (Optional)	6-16	Radiator	3-17
Fog Lights (Optional)	5-20	Radiator Shell Mounting	4-11
Front Bumper	5-2	Rear Bumper Brackets	5-3

INDEX

Rear Bumpers And Cover	5-17	Standard Top	6-19
Rear Deck Lid	6-7	Steering Column	2-7
Rear End	2-2	Steering Column	3-14
Rear Harness Run	3-24	Steering Wheel (Optional)	6-12
Rear Seat	6-4	Temperature Sender	3-12
Rear Seat And Rear Deck Lid Assembly	5-10	Taillights	4-6
Rear Seat Cushion	6-6	Tools And Parts (Miscellaneous)	1-2
Running Board	5-15	Tools To Be Rented	1-1
Seat Belts	6-12	Tonneau Cover	6-26
Seat Installation	6-13	Trunk Liner	5-6
Seat Track Modifications	6-8	Wheels And Tires	1-4
Shifter And Emergency Brake Lever	2-10	Windshield	6-16
Shift Linkage	3-25	Windshield Washer (Optional)	4-9
Side Curtains	6-23	Wind Wings (Optional)	6-17
Spare Tire Mount	5-18	Wiring	7-1
Standard Door Locks	5-11	Wiring Removal	2-9